

TV VERTICAL DEFLECTION

- SYNCHRONIZATION CIRCUIT
- OSCILLATOR AND RAMP GENERATOR
- HIGH POWER GAIN AMPLIFIER
- FLYBACK GENERATOR
- VOLTAGE REGULATOR

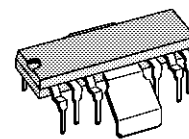

FINDIP
(Plastic Package)

ORDER CODE : TDA1170S

DESCRIPTION

The TDA1170S is a monolithic integrated circuit in a 12-lead quad in-line plastic package. It is intended for use in black and white and colour TV receivers.

PIN CONNECTIONS

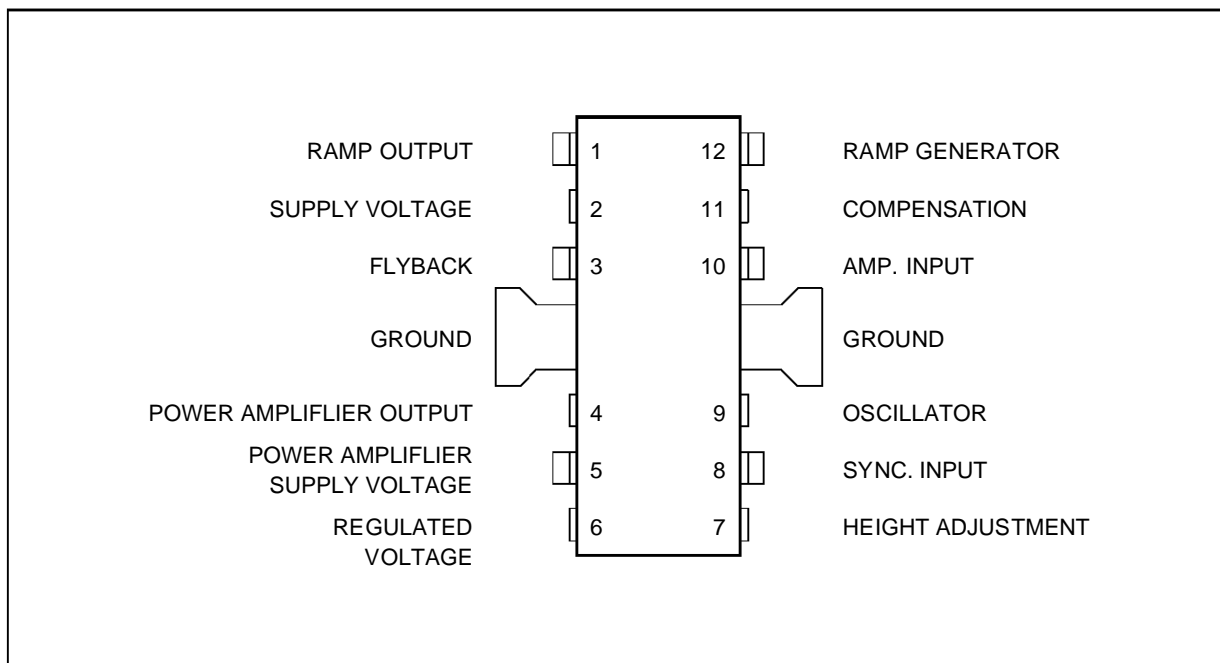

1170S-01.EPS

TDA1170S

BLOCK DIAGRAM

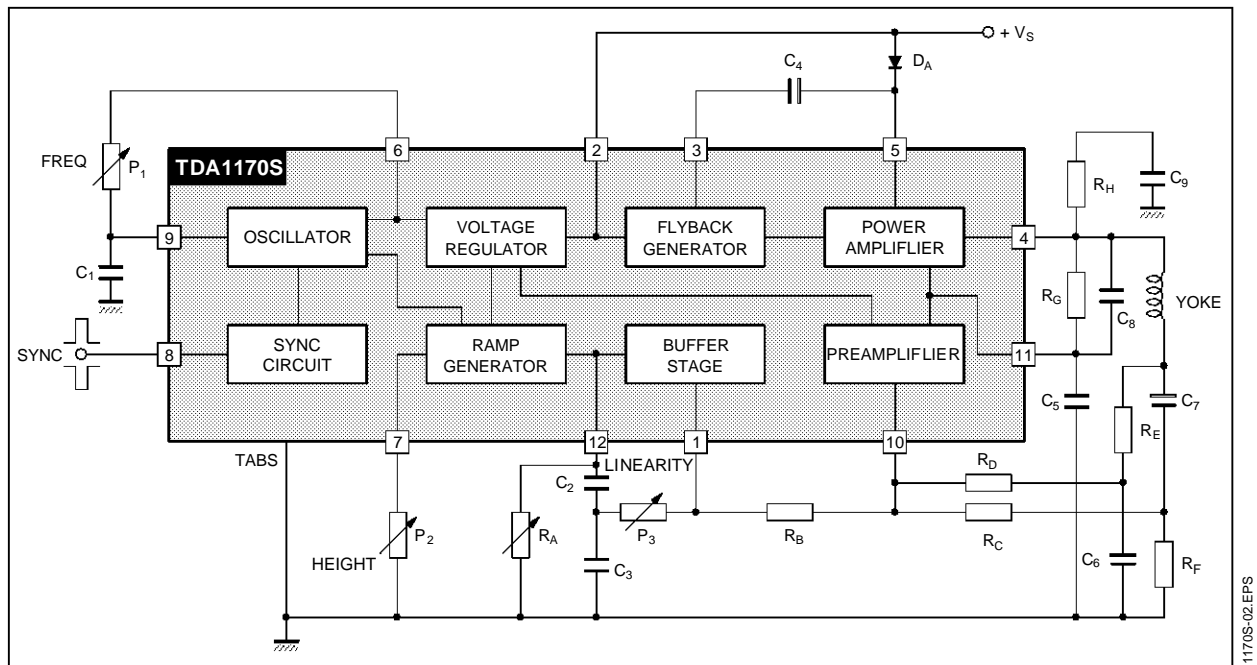

1170S-02.EPS

SCHEMATIC DIAGRAM

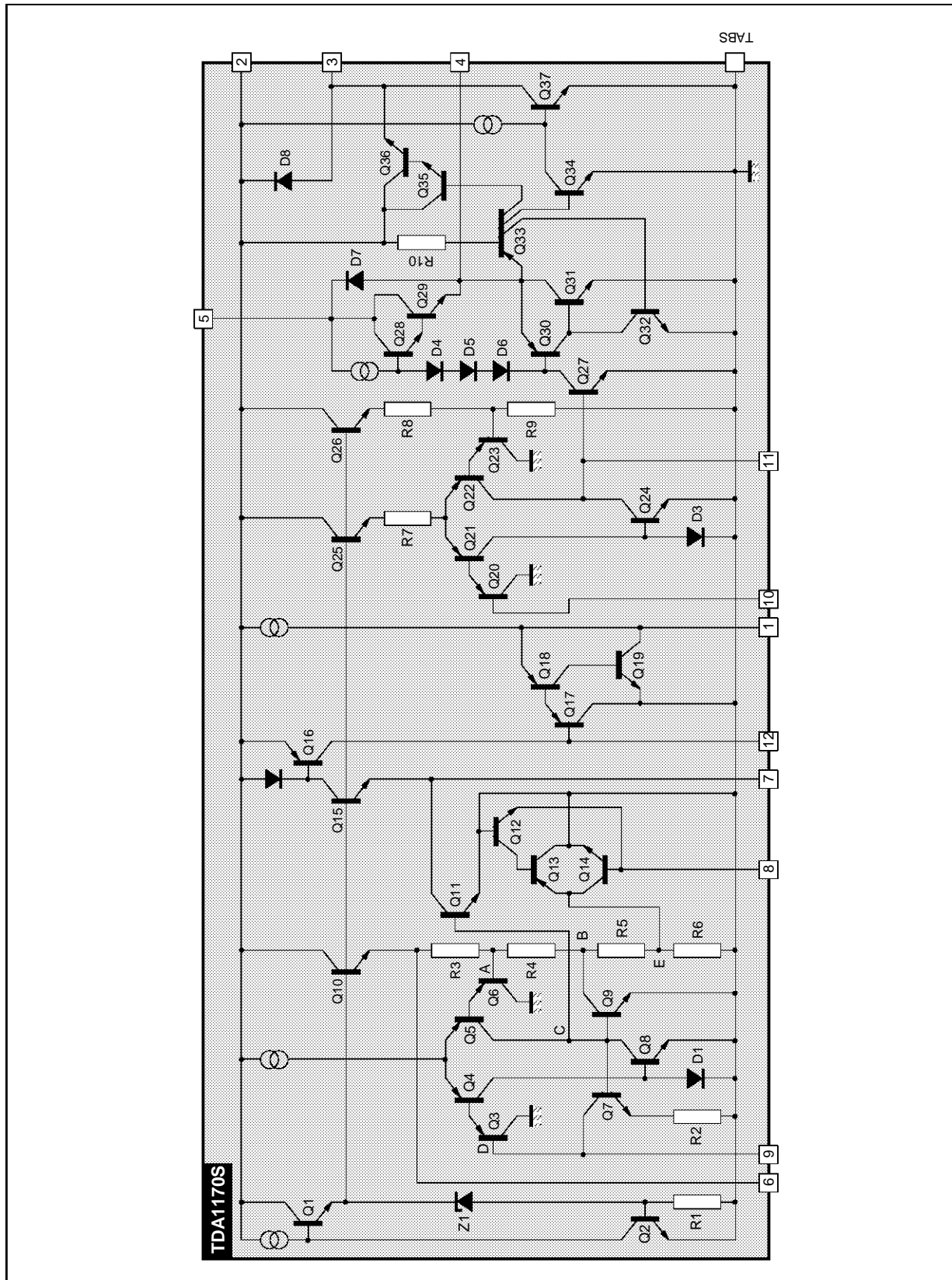

1170S-03.EPS

ABSOLUTE MAXIMUM RATINGS

Symbol	Parameter	Value	Unit
V _S	Supply Voltage at Pin 2	35	V
V ₄ , V ₅	Flyback Peak Voltage	60	V
V ₁₀	Power Amplifier Input Voltage	+ 10 - 0.5	V V
I _o	Output Peak Current (non repetitive) at t = 2msec	2	A
I _o	Output Peak Current at f = 50Hz t ≤ 10μsec	2.5	A
I _o	Output Peak Current at f = 50Hz t > 10μsec	1.5	A
I ₃	Pin 3 DC Current at V ₄ 2	100	mA
I ₃	Pin 3 Peak to Peak Flyback Current for f = 50Hz, t _{fly} ≤ 1.5msec	1.8	A
I ₈	Pin 8 Current	± 20	mA
P _{tot}	Power Dissipation : at T _{tab} = 90 °C at T _{amb} = 80 °C	5 1	W W
T _{stg} , T _j	Storage and Junction Temperature	- 40, + 150	°C

1170S-01.TBL

THERMAL DATA

Symbol	Parameter	Value	Unit
R _{th j-tab}	Thermal Resistance Junction-tab Max	12	°C/W
R _{th j-amb}	Thermal Resistance Junction-ambient Max	70	°C/W

(°) Obtained with tabs soldered to printed circuit with minimized copper area.

1170S-02.TBL

ELECTRICAL CHARACTERISTICS

(refer to the test circuits, V_S = 35V, T_{amb} = 25°C, unless otherwise specified)

DC CHARACTERISTICS

Symbol	Parameter	Test Conditions	Min.	Typ.	Max.	Unit	Fig.
I ₂	Pin 2 Quiescent Current	I ₃ = 0		7	14	mA	1b
I ₅	Pin 5 Quiescent Current	I ₄ = 0		8	15	mA	1b
- I ₉	Oscillator Bias Current	V ₉ = 1V		0.1	1	μA	1a
- I ₁₀	Amplifier Input Bias Current	V ₁₀ = 1V		0.1	1	μA	1b
- I ₁₂	Ramp Generator Bias Current	V ₁₂ = 0		0.02	0.3	μA	1a
- I ₁₂	Ramp Generator Current	I ₇ = 20 μA, V ₁₂ = 0	19	20	24	μA	1b
$\frac{\Delta I_{12}}{I_{12}}$	Ramp Generator Non-linearity	ΔV ₁₂ = 0 to 12V, I ₇ = 20μA		0.2	1	%	1b
V _S	Supply Voltage Range		10		35	V	-
V ₁	Pin 1 Saturation Voltage to Ground	I ₁ = 1 mA		1	1.4	V	-
V ₃	Pin 3 Saturation Voltage to Ground	I ₃ = 10 mA		1.7	2.6	V	1a
V ₄	Quiescent Output Voltage	V _S = 10V R1 = 10kΩ, R2 = 10kΩ	4.1	4.4	4.75	V	1a
		V _S = 35V R1 = 30kΩ, R2 = 10kΩ	8.3	8.8	9.45	V	1a
V _{4L}	Output Saturation Voltage to Ground	- I ₄ = 0.1A - I ₄ = 0.8A		0.9 1.9	1.2 2.3	V V	1c 1c
V _{4H}	Output Saturation Voltage to Supply	I ₄ = 0.1A I ₄ = 0.8A		1.4 2.8	2.1 3.2	V V	1d 1d
V ₆	Regulated Voltage at Pin 6		6.1	6.5	6.9	V	1b
V ₇	Regulated Voltage at Pin 7	I ₇ = 20μA	6.2	6.6	7	V	1b
$\frac{\Delta V_6}{\Delta V_S}, \frac{\Delta V_7}{\Delta V_S}$	Regulated Voltage Drift with Supply Voltage	ΔV _S = 10 to 35V		1		mV/V	1b
V ₁₀	Amplifier Input Reference Voltage		2.07	2.2	2.3	V	-
R ₈	Pin 8 Input Resistance	V ₈ ≤ 0.4V	1			MΩ	1a

1170S-03.TBL

Figure 1 : DC Test Circuit

Figure 1a

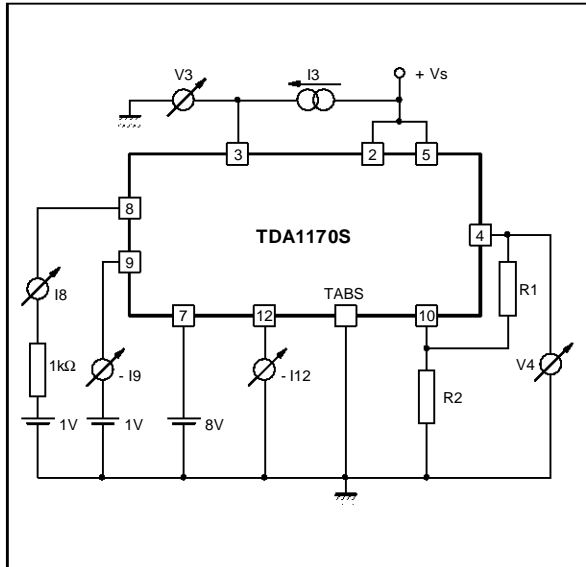

1170S-04.EPS

Figure 1b

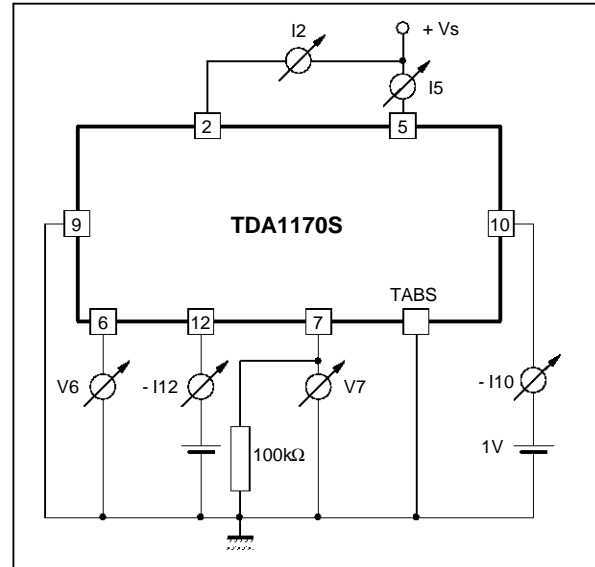

1170S-05.EPS

Figure 1c

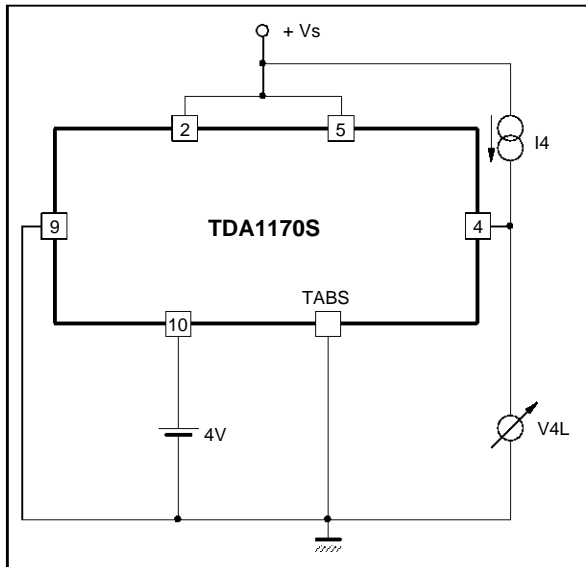

1170S-06.EPS

Figure 1d

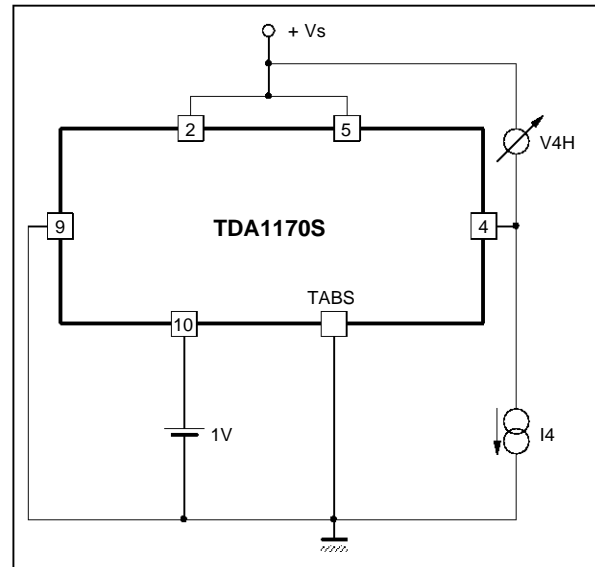

1170S-07.EPS

ELECTRICAL CHARACTERISTICS

(refer to the test circuit, $V_S = 25V$; $f = 50Hz$; $T_{amb} = 25^{\circ}C$, unless otherwise specified)

AC CHARACTERISTICS

Symbol	Parameter	Test Conditions	Min.	Typ.	Max.	Unit
I_s	Supply Current	$I_y = 1App$		140		mA
I_b	Sync. Input Current (positive or negative)		500			μA
V_4	Flyback Voltage	$I_y = 1App$		51		V
V_9	Peak to Peak Oscillator Sawtooth Voltage			2.4		V
t_{fly}	Flyback Time	$I_y = 1App$		0.7		ms
f_o	Free Running Frequency	$(P_1 + R_1) = 300k\Omega$, $C_2 = 0.1 \mu F$ $(P_1 + R_1) = 260k\Omega$, $C_2 = 0.1 \mu F$		42.2 48.5		Hz Hz
Δf	Synchronization Range	$I_b = 0.5mA$	14			Hz
$\frac{\Delta f}{\Delta V_S}$	Frequency Drift with Supply Voltage	$V_S = 10$ to $35V$		0.005		Hz/V
$\frac{\Delta f}{\Delta T_{tab}}$	Frequency Drift with Tab Temperature	$T_{tab} = 40$ to $120^{\circ}C$		0.01		Hz/ $^{\circ}C$

1170S-04.TBL

Figure 2 : AC Test Circuit

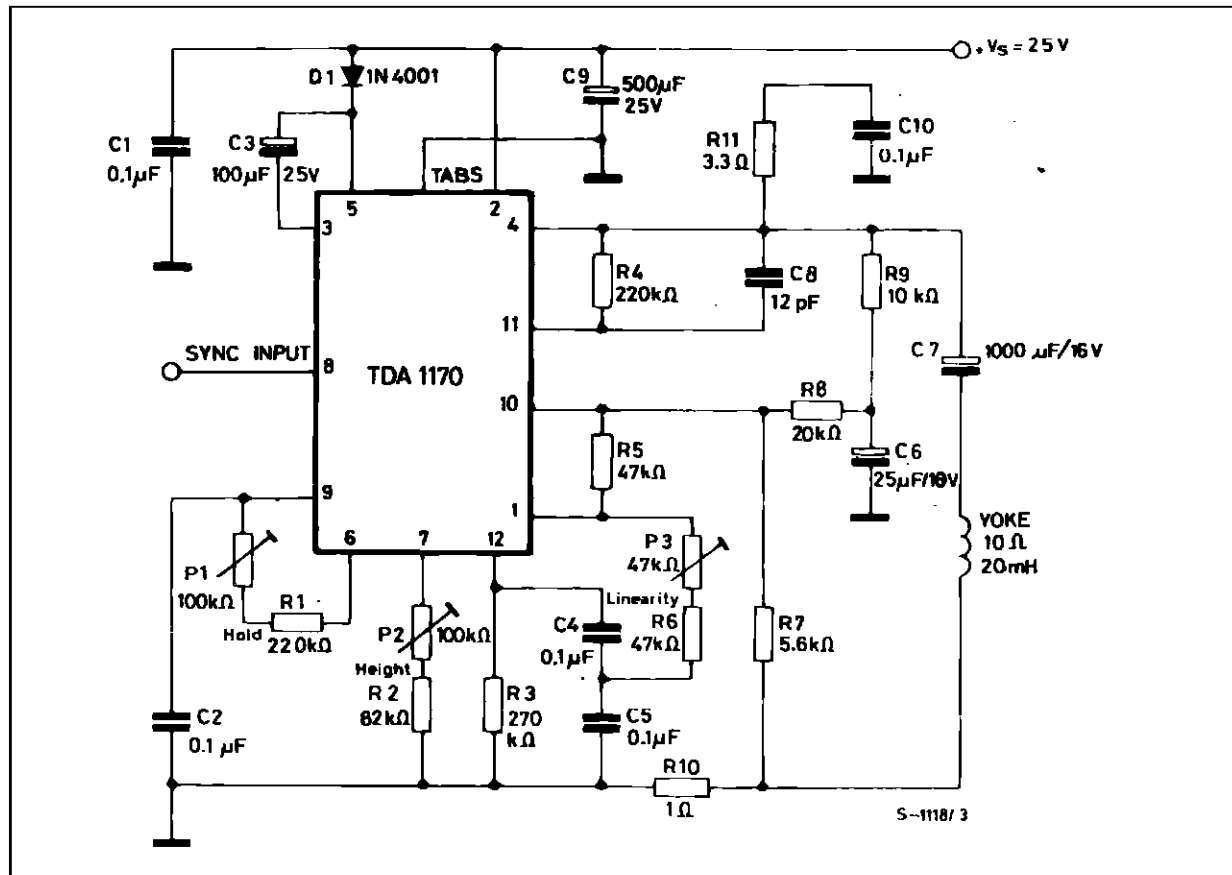

1170S-08.EPS

Figure 3 : Typical Application Circuit for Large Screen B/W TV SET ($R_Y = 10\Omega$, $L_Y = 20mH$, $I_Y = 1APP$)

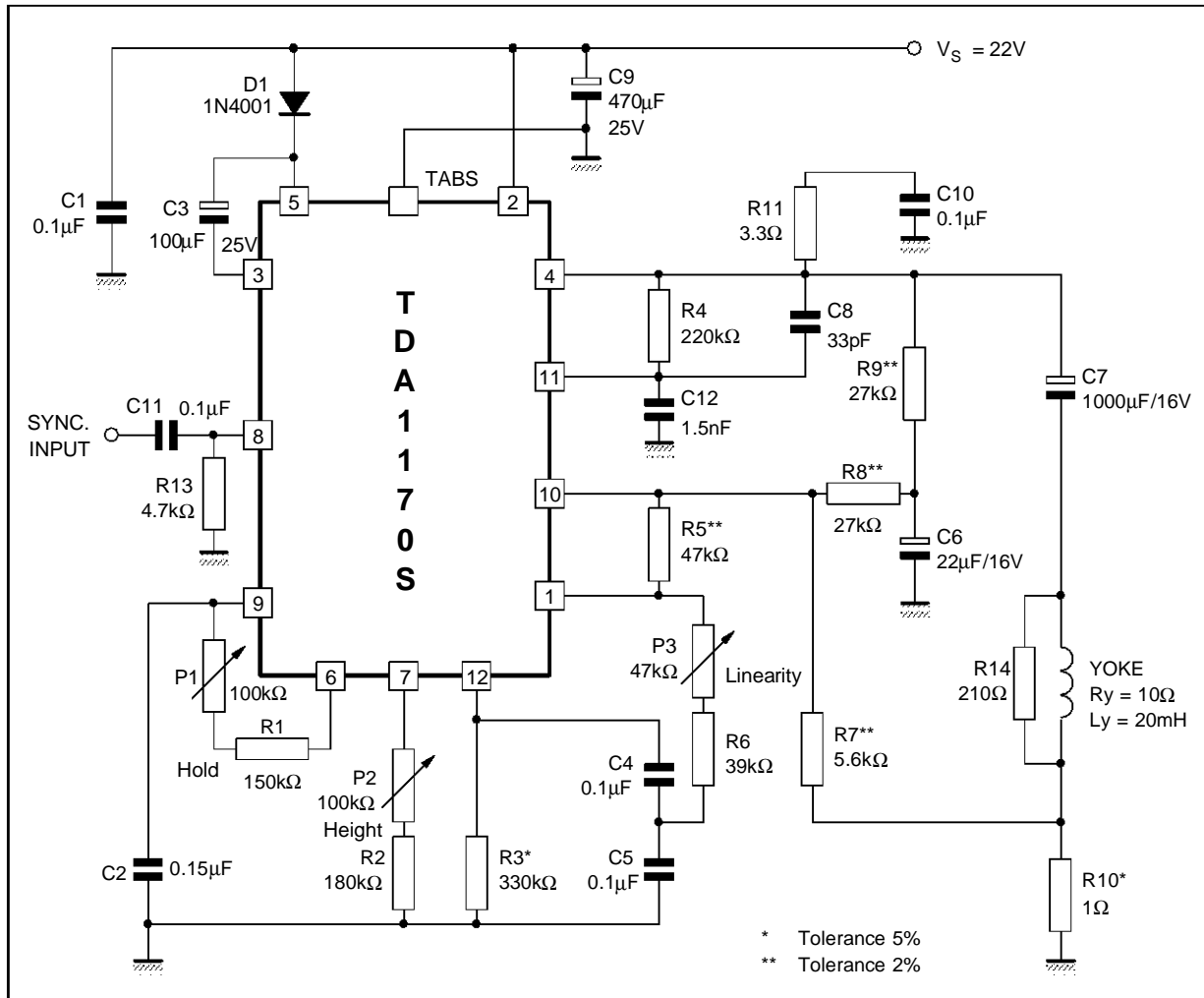

TYPICAL PERFORMANCE

Symbol	Parameter	Value	Unit
V_S	Operating Supply Voltage	22	V
I_S	Supply Current	145	mA
t_{fly}	Flyback Time	0.7	ms
P_{tot}	Power Dissipation	2.3	W
I_Y	Maximum Scanning Current (peak to peak)	1.2	A

For safe working up to $T_{amb} = 60^\circ C$ a heatsink of $R_{th} = 14^\circ C/W$ is required.

MOUNTING INSTRUCTION

The junction to ambient thermal resistance of the TDA 1170S can be reduced by soldering the tabs to a suitable copper area of the printed circuit board (fig. 4) or to an external heatsink (fig. 5).

Figure 4 : Example of P.C Board Copper Area is Used as Heatsink

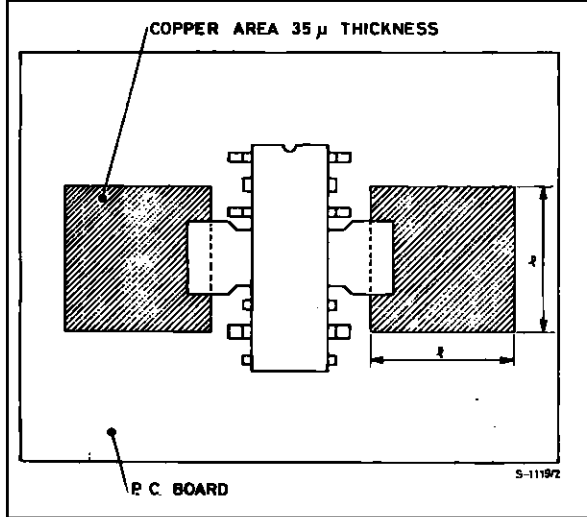

1170S-10.EPS

The diagram of fig. 6 shows the maximum dissippable power P_{tot} and the $R_{th j-amb}$ as a function of the side "s" of two equal square copper areas having a thickness of 35 μ (1.4 mil).

Figure 5 : Example with External Heatsink

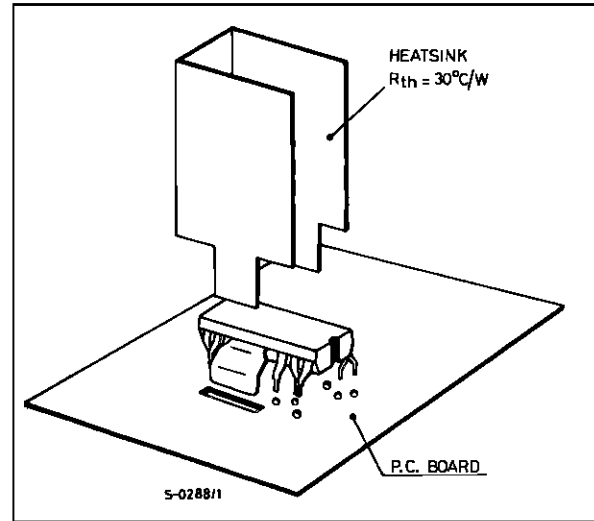

1170S-11.EPS

Figure 6 : Maximum Power Dissipation and Junction-Ambient Thermal Resistance versus "S"

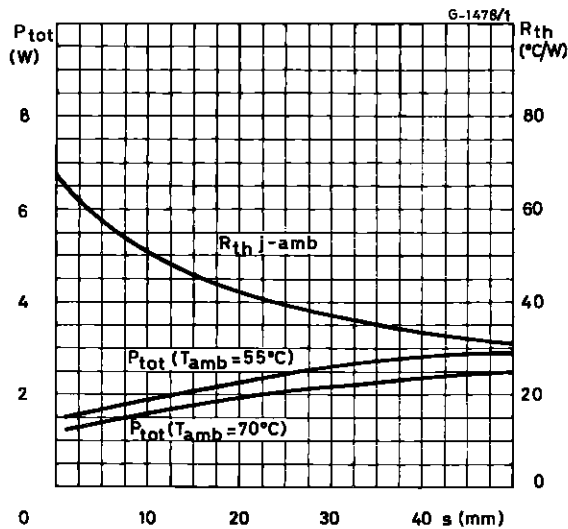

1170S-12.EPS

Figure 7 : Maximum Allowable Power Dissipation versus Ambient Temperature

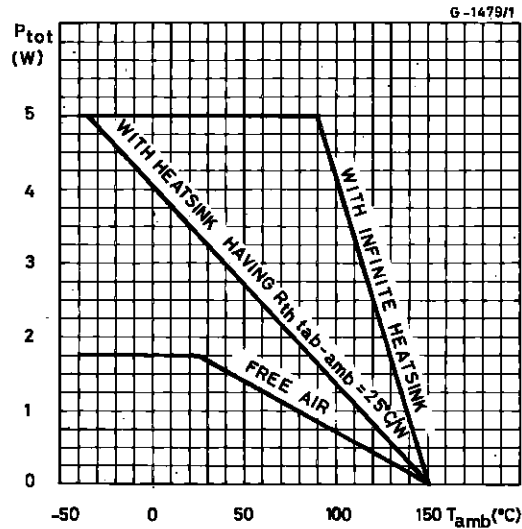

1170S-13.EPS

PACKAGE MECHANICAL DATA : 12 PINS - PLASTIC FINDIP

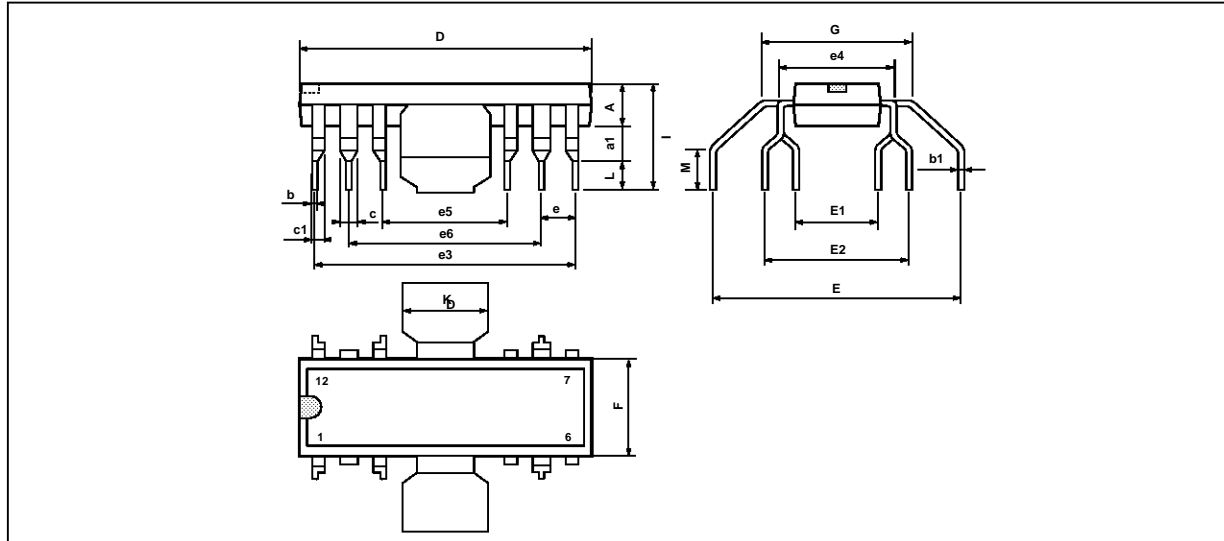

PM-FDIP/EPS

Dimensions	Millimeters			Inches		
	Min.	Typ.	Max.	Min.	Typ.	Max.
A	3.8		4.05	0.150		0.159
a1	1.5		1.75	0.059		0.069
b	0.55		0.6	0.022		0.024
b1	0.3		0.35	0.012		0.014
c		1.32			0.052	
c1		0.94			0.037	
D	19.2		19.9	0.756		0.783
E	16.8	17.2	17.6	0.661	0.677	0.693
E1	4.86		5.56	0.191		0.219
E2	10.11		10.81	0.398		0.426
e	2.29	2.54	2.79	0.090	0.100	0.110
e3	17.43	17.78	18.13	0.686	0.700	0.714
e4		7.62			0.300	
e5	7.27	7.62	7.97	0.286	0.300	0.314
e6	12.35	12.7	13.05	0.486	0.500	0.514
F	6.3		7.1	0.248		0.280
G		9.8			0.386	
I	7.8		8.6	0.307		0.339
K	6.1		6.5	0.240		0.256
L	2.5		2.9	0.098		0.114
M	2.5		3.1	0.098		

FINDIP.TBL

Information furnished is believed to be accurate and reliable. However, SGS-THOMSON Microelectronics assumes no responsibility for the consequences of use of such information nor for any infringement of patents or other rights of third parties which may result from its use. No licence is granted by implication or otherwise under any patent or patent rights of SGS-THOMSON Microelectronics. Specifications mentioned in this publication are subject to change without notice. This publication supersedes and replaces all information previously supplied. SGS-THOMSON Microelectronics products are not authorized for use as critical components in life support devices or systems without express written approval of SGS-THOMSON Microelectronics.

© 1994 SGS-THOMSON Microelectronics - All Rights Reserved

Purchase of I²C Components of SGS-THOMSON Microelectronics, conveys a license under the Philips I²C Patent. Rights to use these components in a I²C system, is granted provided that the system conforms to the I²C Standard Specifications as defined by Philips.

SGS-THOMSON Microelectronics GROUP OF COMPANIES

Australia - Brazil - China - France - Germany - Hong Kong - Italy - Japan - Korea - Malaysia - Malta - Morocco
The Netherlands - Singapore - Spain - Sweden - Switzerland - Taiwan - Thailand - United Kingdom - U.S.A.