

Features

- 7.5 ns pin-to-pin logic delays
- System frequencies up to 140 MHz
- 256 macrocells with 6,000 usable gates
- Available in small footprint packages
 - 144-pin TQFP (116 user I/O pins)
 - 208-pin PQFP (160 user I/O)
 - 280-ball CS BGA (160 user I/O)
- Optimized for 3.3V systems
 - Ultra low power operation
 - 5V tolerant I/O pins with 3.3V core supply
 - Advanced 0.35 micron five metal layer re-programmable process
 - FZP™ CMOS design technology
- Advanced system features
 - In-system programming
 - Input registers
 - Predictable timing model
 - Up to 23 clocks available per logic block
 - Excellent pin retention during design changes
 - Full IEEE Standard 1149.1 boundary-scan (JTAG)
 - Four global clocks
 - Eight product term control terms per logic block
- Fast ISP programming times
- Port Enable pin for additional I/O
- 2.7V to 3.6V industrial grade voltage range
- Programmable slew rate control per output
- Security bit prevents unauthorized access
- Refer to XPLA3 family data sheet (DS012) for architecture description

Description

The XCR3256XL is a 3.3V, 256 macrocell CPLD targeted at power sensitive designs that require leading edge programmable logic solutions. A total of 16 logic blocks provide 6,000 usable gates. Pin-to-pin propagation delays are 7.5 ns with a maximum system frequency of 140 MHz.

TotalCMOS™ Design Technique for Fast Zero Power

Xilinx offers a TotalCMOS CPLD, both in process technology and design technique. Xilinx employs a cascade of CMOS gates to implement its sum of products instead of the traditional sense amp approach. This CMOS gate implementation allows Xilinx to offer CPLDs that are both high performance and low power, breaking the paradigm that to have low power, you must have low performance. Refer to [Figure 1](#) and [Table 1](#) showing the I_{CC} vs. Frequency of our XCR3256XL TotalCMOS CPLD (data taken with 16 up/down, loadable 16-bit counters at 3.3V, 25°C).

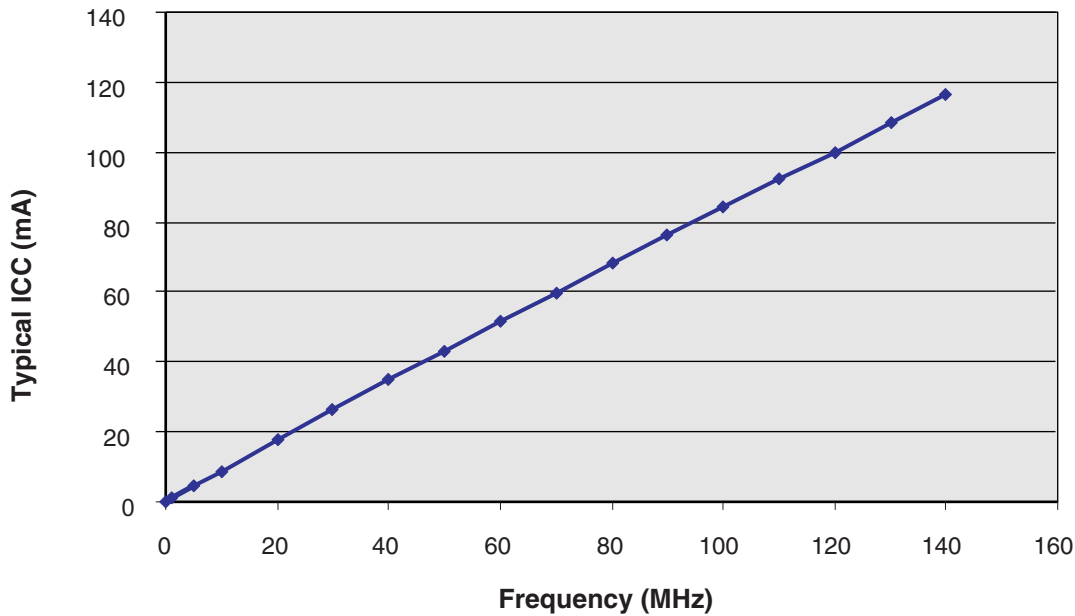

Figure 1: XCR3256XL Typical I_{CC} vs. Frequency at $V_{CC} = 3.3V$, $25^{\circ}C$

Table 1: Typical I_{CC} vs. Frequency at $V_{CC} = 3.3V$, $25^{\circ}C$

Frequency (MHz)	0	1	10	20	40	60	80	100	120	140
Typical I_{CC} (mA)	0.02	0.91	8.87	17.7	34.8	51.5	68	84.2	100.1	116.6

DC Electrical Characteristics Over Recommended Operating Conditions⁽¹⁾

Symbol	Parameter	Test Conditions	Min.	Max.	Unit
V_{OH}	Output High voltage for 3.3V outputs	$I_{OH} = -8$ mA	2.4	-	V
V_{OL}	Output Low voltage for 3.3V outputs	$I_{OL} = 8$ mA	-	0.4	V
I_{IL}	Input leakage current	$V_{IN} = GND$ or V_{CC}	-10	10	μA
I_{IH}	I/O High-Z leakage current	$V_{IN} = GND$ or V_{CC}	-10	10	μA
I_{CCSB}	Standby current	$V_{CC} = 3.6V$	-	100	μA
I_{CC}	Dynamic current ^(2,3)	$f = 1$ MHz	-	2	mA
		$f = 50$ MHz	-	60	mA
C_{IN}	Input pin capacitance ⁽⁴⁾	$f = 1$ MHz	-	8	pF
C_{CLK}	Clock input capacitance ⁽⁴⁾	$f = 1$ MHz	5	12	pF
$C_{I/O}$	I/O pin capacitance ⁽⁴⁾	$f = 1$ MHz	-	10	pF

Notes:

1. See XPLA3 family data sheet (DS012) for recommended operating conditions.
2. See Table 1, Figure 1 for typical values.
3. This parameter measured with a 16-bit, loadable up/down counter loaded into every logic block, with all outputs disabled and unloaded. Inputs are tied to V_{CC} or ground. This parameter guaranteed by design and characterization, not testing.
4. Typical values not tested.

AC Electrical Characteristics Over Recommended Operating Conditions^(1,2)

Symbol	Parameter	-7		-10		-12		Unit
		Min.	Max.	Min.	Max.	Min.	Max.	
T _{PD1}	Propagation delay time (single p-term)	-	7.0	-	9.0	-	10.8	ns
T _{PD2}	Propagation delay time (OR array) ⁽³⁾	-	7.5	-	10.0	-	12.0	ns
T _{CO}	Clock to output (global synchronous pin clock)	-	4.5	-	5.8	-	6.9	ns
T _{SUF}	Setup time fast	2.0	-	2.5	-	3.0	-	ns
T _{SU}	Setup time	4.8	-	6.5	-	7.9	-	ns
T _H	Hold time	0	-	0	-	0	-	ns
T _{WLH}	Global clock pulse width (High or Low)	3.0	-	4.0	-	5.0	-	ns
T _{PLH}	P-term clock pulse width (High or Low)	4.5	-	6.0	-	7.5	-	ns
T _R	Input rise time	-	20	-	20	-	20	ns
T _L	Input fall time	-	20	-	20	-	20	ns
f _{SYSTEM}	Maximum system frequency	-	140	-	105	-	88	MHz
T _{CONFIG}	Configuration time ⁽⁴⁾	-	40	-	40	-	40	μs
T _{POE}	P-term OE to output enabled	-	9.0	-	11.0	-	13.0	ns
T _{POD}	P-term OE to output disabled ⁽⁵⁾	-	9.0	-	11.0	-	13.0	ns
T _{PCO}	P-term clock to output	-	8.0	-	10.3	-	12.4	ns
T _{PAO}	P-term set/reset to output valid	-	9.0	-	11.0	-	13.0	ns

Notes:

1. Specifications measured with one output switching.
2. See XPLA3 Family Data Sheet (DS012) for recommended operating conditions.
3. See [Figure 4](#) for derating.
4. Typical current draw during configuration is 10 mA at 3.6V.
5. Output C_L = 5 pF.

Timing Model

The XPLA3 architecture follows a simple timing model that allows deterministic timing in design and redesign. The basic timing model is shown in **Figure 2**. One key feature of the XPLA3 CPLD is the ability to have up to 48 product term inputs into a single macrocell and maintain consistent timing. This is achieved through the use of a fully populated PLA (Programmable AND Programmable OR Array) which also has the ability to share product terms and only use the required amount of product terms per macrocell. There is a fast path (T_{LOGI1}) into the macrocell which is used if there is a single product term. The T_{LOGI2} path is used for multiple

product term timing. For optimization of logic, the XPLA3 CPLD architecture includes a Fold-back NAND path (T_{LOGI3}). There is a fast input path to each macrocell if used as an Input Register (T_{FIN}). XPLA3 also includes universal control terms (T_{UDA}) that can be used for synchronization of the macrocell registers in different logic blocks. There is also slew rate control and output enable control on a per macrocell basis.

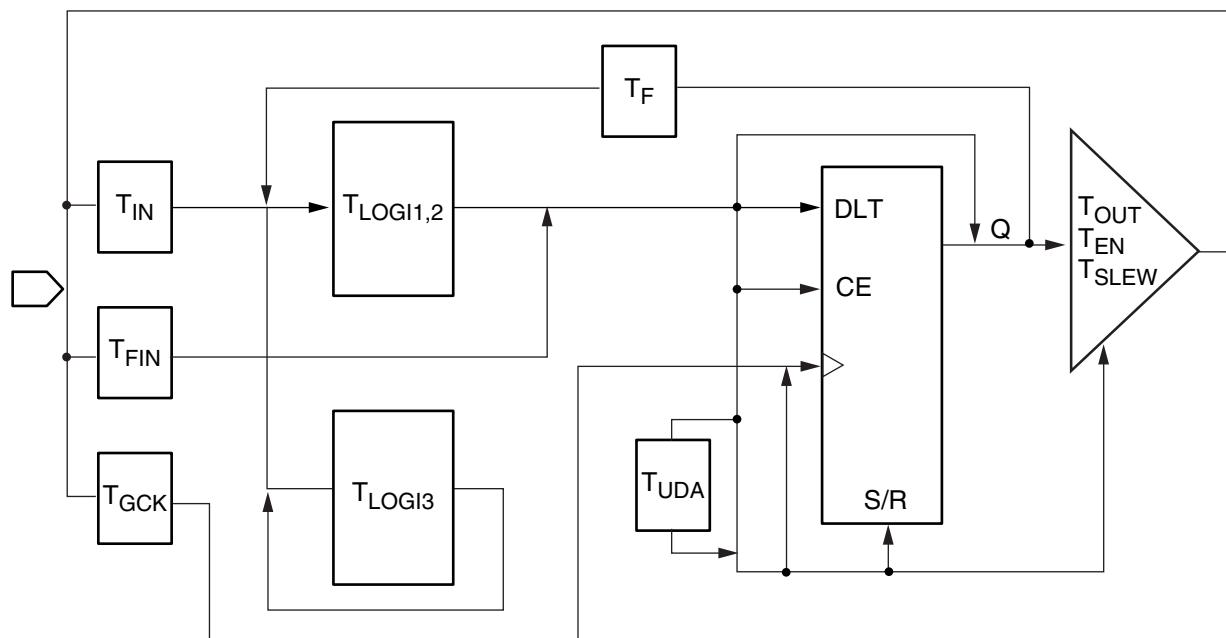

DS017_02_042800

Figure 2: XPLA3 Timing Model

Internal Timing Parameters

Symbol	Parameter	-7		-10		-12		Unit
		Min.	Max.	Min.	Max.	Min.	Max.	
Buffer Delays								
T _{IN}	Input buffer delay	-	2.5	-	3.3	-	4.0	ns
T _{FIN}	Fast input buffer delay	-	2.2	-	2.8	-	3.3	ns
T _{GCK}	Global clock buffer delay	-	1.0	-	1.3	-	1.5	ns
T _{OUT}	Output buffer delay	-	2.5	-	2.8	-	3.3	ns
T _{EN}	Output buffer enable/disable delay	-	4.5	-	5.2	-	6.0	ns
Internal Register and Combinatorial Delays								
T _{LDI}	Latch transparent delay	-	1.3	-	1.6	-	2.0	ns
T _{SUI}	Register setup time	0.8	-	1.0	-	1.2	-	ns
T _{HI}	Register hold time	4.0	-	5.5	-	6.7	-	ns
T _{ECSU}	Register clock enable setup time	2.0	-	2.5	-	3.0	-	ns
T _{ECHO}	Register clock enable hold time	3.0	-	4.5	-	5.5	-	ns
T _{COI}	Register clock to output delay	-	1.0	-	1.3	-	1.6	ns
T _{AOI}	Register async. S/R to output delay	-	2.0	-	2.0	-	2.2	ns
T _{RAI}	Register async. recovery	-	5.0	-	7.0	-	8.0	ns
T _{LOGI1}	Internal logic delay (single p-term)	-	2.0	-	2.5	-	3.0	ns
T _{LOGI2}	Internal logic delay (PLA OR term)	-	2.5	-	3.5	-	4.2	ns
Feedback Delays								
T _F	ZIA delay	-	2.8	-	3.7	-	4.4	ns
Time Adders								
T _{LOGI3}	Fold-back NAND delay	-	6.0	-	8.0	-	9.5	ns
T _{UDA}	Universal delay	-	2.0	-	2.5	-	3.0	ns
T _{SLEW}	Slew rate limited delay	-	4.0	-	5.0	-	6.0	ns

Switching Characteristics

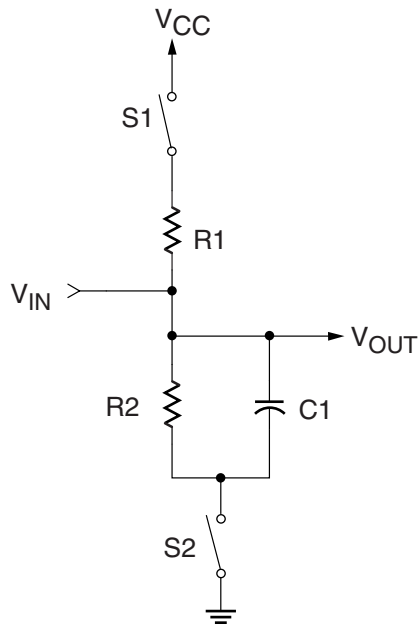

Component	Values
R1	390Ω
R2	390Ω
C1	35 pF

Measurement	S1	S2
T _{POE} (High)	Open	Closed
T _{POE} (Low)	Closed	Open
T _P	Closed	Closed

Note: For T_{POD}, C1 = 5 pF

DS013_03_050200

Figure 3: AC Load Circuit

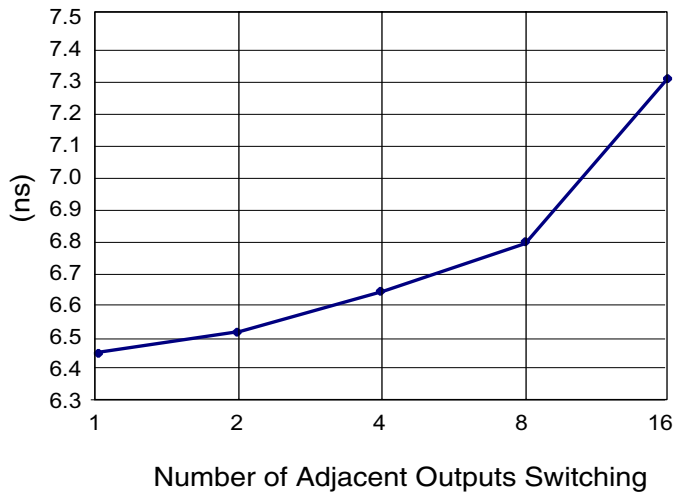

DS013_04_042800

Figure 4: Derating Curve for T_{PD2}

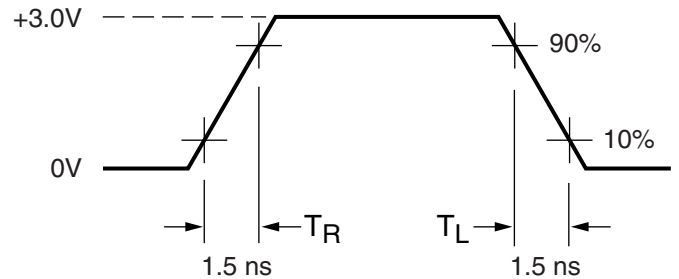

Measurements:

All circuit delays are measured at the +1.5V level of inputs and outputs, unless otherwise specified.

DS017_05_042800

Figure 5: Voltage Waveform

Pin Descriptions

Table 2: XCR3256XL Pin Descriptions

Function	CS280	PQ208	TQ144	BScan Order
A0	E18	6	106	736
A1	E19	7	-	732
A2	F15*	8*	104 (TDO)	728*
A3	F17	9	103	724
A4	F18	10	102	720
A11	F19	11	101	710
A12	G16	12	100	706
A13	G17	13	99	702
A14	G19	15	-	698
A15	H16	16	-	694
B0	B19	4	107	552
B1	B18	3	108	548
B2	B17	206	-	544
B3	A18	205	-	540
B4	A17	204	109	536
B11	C16	203	110	526
B12	A16	202	111	522
B13	E15	201	-	518
B14	D15	199	112	514
B15	A15	198	113	510
C0	H17	17	98	690
C1	H18	18	97	686
C2	H19	19	96	682
C3	J16	20	94	678
C4	J17	21	93	674
C11	J18	22	92	664
C12	K16	24	-	660
C13	K17	25	91	656
C14	K18	26	90	652
C15	L16	27	-	648
CLK0/IN0	A10	181	128	-
CLK1/IN1	D11	182	127	-
CLK2/IN2	C11	183	126	-
CLK3/IN3	B11	184	125	-

Table 2: XCR3256XL Pin Descriptions (Continued)

Function	CS280	PQ208	TQ144	BScan Order
D0	E14	197	114	506
D1	D14	196	116	502
D2	A14	195	117	498
D3	C13	194	-	494
D4	B13	193	118	490
D11	A13	192	119	480
D12	A12	190	120	476
D13	C12 (TDO)	189 (TDO)	121	-
D14	B12	188	-	468
D15	D12	187	122	464
E0	L17*	28*	89 (TCK)	644*
E1	L18	29	-	640
E2	L19 (TCK)	30 (TCK)	88	-
E3	M16	31	87	632
E4	M18	33	86	628
E11	M17	34	84	618
E12	N16	35	-	614
E13	N19	36	83	610
E14	N18	37	82	606
E15	N17	38	-	602
F0	U10	78	-	460
F1	T10	77	55	456
F2	W11	76	56	452
F3	U11	73	-	448
F4	T11	71	60	444
F11	W12	70	61	434
F12	U12	69	62	430
F13	T12	68	63	426
F14	V13	67	-	422
F15	U13	66	65	418
G0	P16	39	81	598
G1	P18	40	-	594
G2	R19	42	80	590
G3	R16	43	79	586
G4	R18	44	78	582

*Note: BScan Order for CS280 and PQ208 only.

Table 2: XCR3256XL Pin Descriptions (Continued)

Function	CS280	PQ208	TQ144	BScan Order
G11	R17	45	77	572
G12	R15	46	-	568
G13	T17	47	75	564
G14	T16	48	74	560
G15	U19	49	-	556
GND	E10	82	52	-
GND	E11	75	57	-
GND	E12	185	124	-
GND	E13	180	129	-
GND	E5	152	3	-
GND	E7	134	17	-
GND	E8	94	33	-
GND	E9	72	59	-
GND	G15	50	64	-
GND	G5	32	85	-
GND	H15	14	105	-
GND	H5	200	135	-
GND	J15	174	-	-
GND	J5	-	-	-
GND	K15	-	-	-
GND	K5	-	-	-
GND	L15	-	-	-
GND	L5	-	-	-
GND	M15	-	-	-
GND	M5	-	-	-
GND	N15	-	-	-
GND	N5	-	-	-
GND	R7	-	-	-
GND	R8	-	-	-
GND	R9	-	-	-
GND	R10	-	-	-
GND	R11	-	-	-
GND	R12	-	-	-
GND	R13	-	-	-
H0	T13	65	66	414
H1	W14	64	67	410

Table 2: XCR3256XL Pin Descriptions (Continued)

Function	CS280	PQ208	TQ144	BScan Order
H2	T14	62	68	406
H3	R14	61	69	402
H4	W15	60	-	398
H11	U15	59	70	388
H12	V15	58	-	384
H13	T15	57	71	380
H14	V16	56	-	376
H15	W17	55	72	372
I0	B1	153	2	368
I1	C3	154	1	364
I2	A4	159	-	360
I3	B5	160	-	356
I4	C5	161	143	352
I11	A5	162	-	342
I12	E6	163	142	338
I13	D6	164	141	334
I14	B6	166	140	330
I15	A6	167	139	326
J0	D2*	151*	4 (TDI)	184*
J1	D1	150	-	180
J2	E3	149	5	176
J3	E2	148	6	172
J4	E4	147	7	168
J11	E1	146	8	158
J12	F5	145	-	154
J13	F3	144	9	150
J14	F4	142	10	146
J15	G3	141	11	142
K0	D7	168	-	322
K1	C7	169	-	318
K2	B7	170	138	314
K3	A7	171	-	310
K4	C8	172	137	306
K11	B8	173	136	296
K12	C9	175	134	292
K13	B9 (TDI)	176 (TDI)	133	-

*Note: BScan Order for CS280 and PQ208 only.

Table 2: XCR3256XL Pin Descriptions (Continued)

Function	CS280	PQ208	TQ144	BScan Order
K14	D10	177	132	284
K15	C10	178	131	280
L0	G2	140	-	138
L1	G1	139	-	134
L2	G4	138	12	130
L3	H1	137	14	126
L4	H3	136	15	122
L11	H2	135	16	112
L12	J2	133	-	108
L13	J3	132	18	104
L14	K2	131	19	100
L15	K3	130	-	96
M0	W10	79	-	276
M1	T9	80	54	272
M2	U9	81	53	268
M3	T8	84	-	264
M4	T7	86	49	260
M11	W7	87	48	250
M12	V7	88	47	246
M13	U7	89	46	242
M14	W6	90	-	238
M15	T6	91	45	234
N0	K4*	129*	20 (TMS)	92*
N1	L1	128	-	88
N2	L2 (TMS)	127 (TMS)	21	-
N3	L3	126	22	80
N4	M1	124	23	76
N11	M3	123	25	66
N12	M4	122	-	62
N13	N1	121	26	58
N14	N2	120	27	54
N15	N3	119	28	50
O0	V6	92	44	230
O1	U6	93	43	226
O2	R6	95	42	222

Table 2: XCR3256XL Pin Descriptions (Continued)

Function	CS280	PQ208	TQ144	BScan Order
O3	W5	96	41	218
O4	T5	97	40	214
O11	V5	98	-	204
O12	U5	99	39	200
O13	W4	100	38	196
O14	U4	101	-	192
O15	W3	102	37	188
P0	P1	118	-	46
P1	P2	117	-	42
P2	P4	115	29	38
P3	R3	114	30	34
P4	R2	113	31	30
P11	R4	112	32	20
P12	T3	111	-	16
P13	U1	110	34	12
P14	V1	109	35	8
P15	U2	108	36	4
PORT_EN	P3	116	13	-
V _{CC}	V9	83	51	-
V _{CC}	V11	74	58	-
V _{CC}	A11	186	123	-
V _{CC}	B10	179	130	-
V _{CC}	F2	143	24	-
V _{CC}	L4	125	50	-
V _{CC}	V2	107	73	-
V _{CC}	U8	85	76	-
V _{CC}	U14	63	95	-
V _{CC}	T18	41	115	-
V _{CC}	P15	23	144	-
V _{CC}	J19	5	-	-
V _{CC}	D17	191	-	-
V _{CC}	C14	165	-	-
V _{CC}	D13	-	-	-
V _{CC}	C6	-	-	-

*Note: BScan Order for CS280 and PQ208 only.

Ordering Information

Example: XCR3256XL -7 PQ 208 C

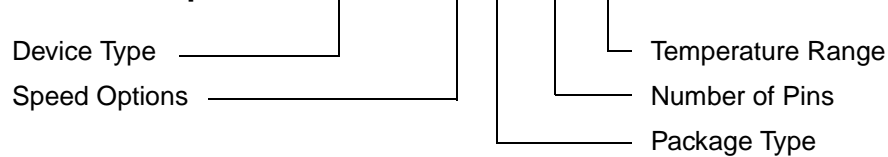

Speed Options

-12: 12 ns pin-to-pin delay
-10: 10 ns pin-to-pin delay
-7: 7.5 ns pin-to-pin delay

Temperature Range

C = Commercial, $T_A = 0^{\circ}\text{C}$ to $+70^{\circ}\text{C}$
I = Industrial, $T_A = -40^{\circ}\text{C}$ to $+85^{\circ}\text{C}$

Packaging Options

TQ144: 144-pin Thin Quad Flat Package
PQ208: 208-pin Plastic Quad Flat Package
CS280: 280-ball Chip Scale Package

Table 3: XCR3256XL JTAG Pinout by package Type

Device	(Pin Number)				
	TCK	Port Enable	TMS	TDI	TDO
XCR3256XL 144-pin TQ	89	13	20	4	104
208-pin PQ	30	116	127	176	189
280-pin CS	L19	P3	L2	B9	C12

Component Compatibility

Pins	144	208	280
Type	Plastic TQFP	Plastic PQFP	Plastic BGA
Code	TQ144	PQ208	CS280
XCR3256XL	-7	C	C
	-10	C, I	C, I
	-12	C, I	C, I

Revision History

The following table shows the revision history for this document

Date	Version	Revision
01/21/00	1.0	Initial Xilinx release.
02/10/00	1.1	Updated Pinout table.
05/03/00	1.2	Minor updates and added Boundary Scan to pinout table.