



FH101

High Dynamic Range FET

Product Features

- 50-3000 MHz Bandwidth
- +36 dBm Output IP3
- 1.2 dB Noise Figure
- 18 dB Gain
- +18 dBm P1dB
- Single or Dual Supply Operation
- MTBF >100 Years
- SOT-89 SMT Package



Actual Size

Product Description

The FH101 is a high dynamic range FET packaged in a low cost surface mount package. The device is available in both the standard SOT-89 package and the environmentally friendly lead-free and “green” SOT-89 package. The combination of low noise figure and high output IP3 at the same bias point makes it ideal for receiver and transmitter applications. The FH101 achieves +36 dBm OIP3 at a mounting temperature of 85°C with an associated MTBF of >100 years. The package is a SOT-89. All devices are 100% RF and DC tested.

The product is targeted for applications where high linearity is required.

Functional Diagram

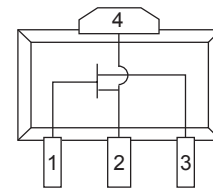

Function	Pin No.
Gate	1
Source	2
Drain	3
Source	4

Specifications

DC Electrical Parameter	Units	Min.	Typical	Max.
Saturated Drain Current, Idss	mA	100	140	170
Transconductance, Gm	mS		120	
Pinch Off Voltage, Vp	V	-3.0	-1.5	

RF Parameter	Units	Min.	Typical	Max.
Small Signal Gain, Gss	dB	17	18	
Max Stable Gain, Gmsg	dB		23	
Output IP3	dBm	32	36	
Output P1dB	dBm		18	
Noise Figure, NF ⁷	dB		1.2	

Notes:

1. DC and RF parameters measured under the following conditions unless otherwise noted. 25°C with Vds = 5.0 V, Vgs = 0 V, test frequency = 800 MHz, 50 W system.
2. OIP3 measured with two tones at an output power of 5 dBm/tone separated by 10 MHz. The suppression on the largest IM3 product is used to calculate the OIP3 using a 2:1 slope rule.
3. Device needs appropriate match to become unconditionally stable.
4. Degradation of OIP3 occurs at low temperatures. Minimum typical OIP3 at -40°C is +36 dBm.
5. Idss is measured with Vgs = 0 V.
6. Pinch off voltage is measured when Ids = 0.6 mA.
7. Measured with Vds = 3.3 V, 50% Idss.

Absolute Maximum Ratings

Parameter	Rating
Drain to Source Voltage	+6.0 V
Gate to Source Voltage	-6.0 V
Gate Current	4.5 mA
Operating Case Temperature	-40 to +85°C
Storage Temperature	-55 to +125°C
Input RF Power (continuous)	+10 dBm

Operation of this device above any of these parameters may cause permanent damage.

Typical Parameters

Parameter	Units	Typical	
Frequency	MHz	900	1900
S21	dB	19.0	16.0
S11	dB	-10.7	-12.3
S22	dB	-9.7	-17.2
Output IP3	dBm	+38.0	+33.6
Output P1dB	dBm	+18.8	+19.1
Noise Figure	dB	2.7	3.1
Drain Bias Supply	5 V @ 140 mA		
Gate Bias	0 V		

Typical parameters reflect performance in an application circuit.

Ordering Information

Part No.	Description
FH101	High Dynamic Range FET (lead ¹)
FH101-G	High Dynamic Range FET (lead-free) ²

¹ Product may contain lead-bearing materials. Maximum +235°C reflow temperature.

² Product does not contain lead-bearing materials. Maximum +260°C reflow temperature. Also compatible with leaded soldering process.

Specifications and information are subject to change without notice.



OIP3 vs. Frequency

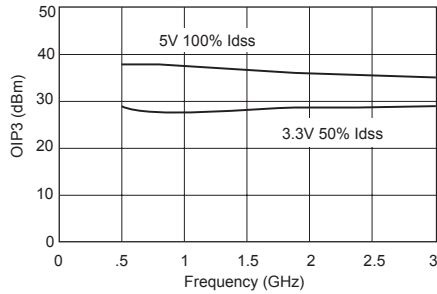

Gain vs. Temperature

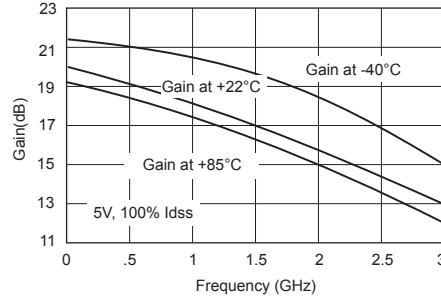

NF vs. Frequency

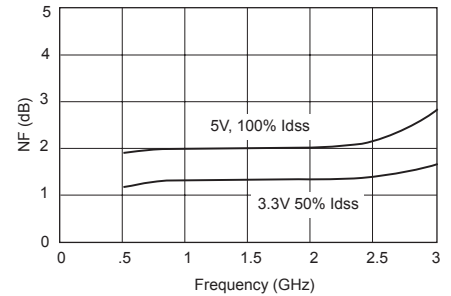

OIP3 vs. Temperature

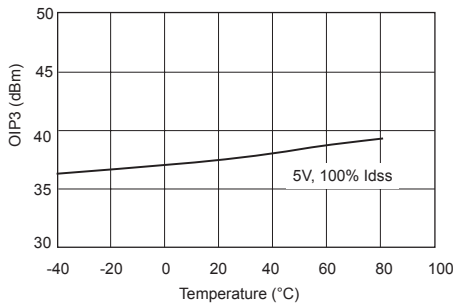

OIP3 vs. Power Out

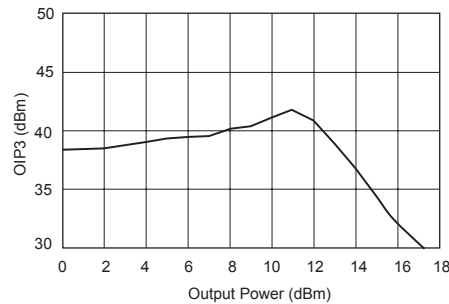

S-Parameters

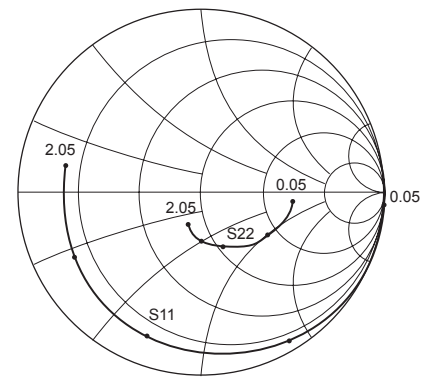

S11 and S22

Thermal Specifications

Parameter	Rating
Operating Case Temperature	-40 to +85°C
Thermal Resistance (Maximum)	59°C/W
Junction Temperature (Recommended Maximum)	+160°C

Notes:

1. Thermal Resistance determined at Maximum Tab Temperature and Maximum Power Dissipation.
2. Recommended Maximum Junction Temperature insures a MTBF of 1 million hours.

MTBF vs. Temperature

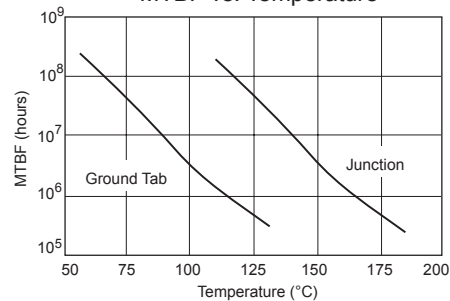

Specifications and information are subject to change without notice.



Outline Drawing

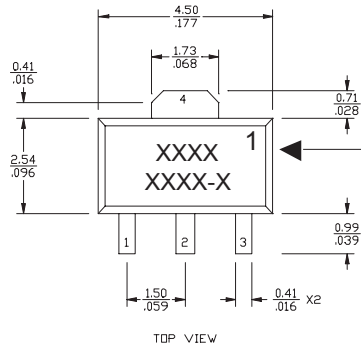

'XXXX' = Part Designation = 'FH1' for FH101
 'XXXX' = Part Designation = 'FH1G' for FH101-G
 '1' = Lasermark
 'XXXX-X' = Lot Code

mm
inch

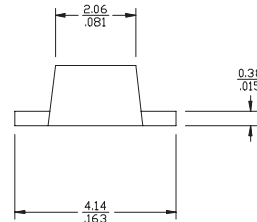
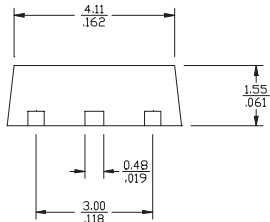

ESD / MSL Information

ESD Classification: Class 1B
 Value: Passes at 600 V
 Test: Human Body Model (HBM)
 Standard: JEDEC Standard JESD22-A114

ESD Classification: Class IV
 Value: Passes at 1000 V
 Test: Charged Device Model (CDM)
 Standard: JEDEC Standard JESD22-C101

FH101
 MSL Rating: Level 3 at +225°C convection reflow
 Standard: JEDEC Standard J-STD-020

FH101-G
 MSL Rating: Level 3 at +260°C convection reflow
 Standard: JEDEC Standard J-STD-020

Land Pattern

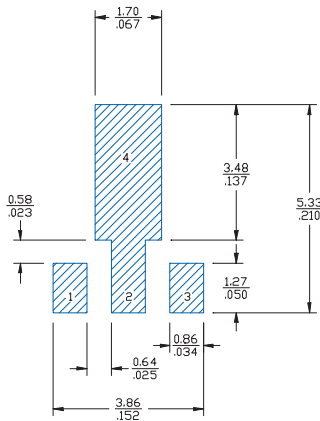

Mounting Configuration

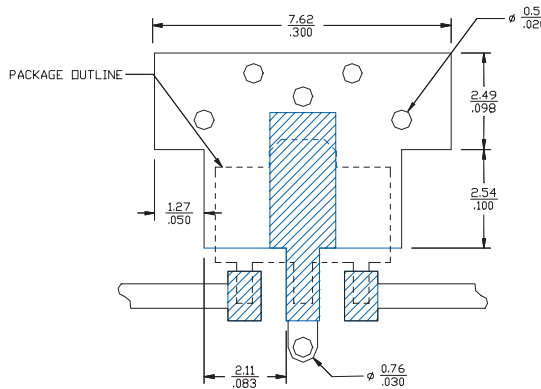

FUNCTION	PIN NO.
INPUT	1
GROUND	2
OUTPUT (BIAS)	3
GROUND	4

Notes: 1. Ground vias are critical for thermal and RF grounding considerations.
 2. A minimum of 6 ground vias are required for 14 mil and 28 mil FR4 board.
 3. If your PCB design rules allow, ground vias should be placed under the land pattern for better RF and thermal performance. Otherwise ground vias should be placed as close to land pattern as possible.
 4. Trace width depends on PC board.



Caution! ESD sensitive device.

Specifications and information are subject to change without notice.



Typical Test Data

S-Parameters (Vds = +5 V, 100% Idss, T = 22°C, de-embedded into package device in a 50 ohm system)

Freq (GHz)	S11 (Mag)	S11 (Ang)	S21 (dB)	S21 (Mag)	S21 (Ang)	S12 (Mag)	S12 (Ang)	S22 (Mag)	S22 (Ang)	K Value
0.05	0.997	-3.940	19.789	9.760	175.000	0.002	97.900	0.502	-6.360	0.0004
0.30	0.993	-22.800	19.370	9.300	162.000	0.015	76.000	0.492	-15.200	0.0570
0.55	0.968	-42.900	19.133	9.050	147.000	0.027	66.100	0.455	-26.300	0.1303
0.80	0.928	-62.100	18.639	8.550	133.000	0.037	54.400	0.424	-36.400	0.2302
1.05	0.905	-79.100	18.116	8.050	121.000	0.046	45.800	0.398	-47.300	0.2490
1.30	0.868	-95.800	17.478	7.480	109.000	0.053	35.500	0.361	-56.700	0.3267
1.55	0.841	-111.000	16.852	6.960	97.500	0.059	27.400	0.329	-66.400	0.3761
1.80	0.815	-126.000	16.191	6.450	86.900	0.063	20.100	0.308	-75.000	0.4231
2.05	0.780	-142.000	15.519	5.970	76.800	0.068	13.400	0.296	-81.500	0.4842
2.30	0.766	-155.000	14.901	5.560	67.300	0.071	6.700	0.268	-89.400	0.5293
2.55	0.754	-168.000	14.253	5.160	58.300	0.073	0.425	0.240	-96.100	0.5844
2.80	0.754	-180.000	13.679	4.830	49.600	0.074	-5.810	0.216	-103.000	0.6190
3.05	0.748	169.000	13.103	4.520	41.200	0.075	-12.300	0.191	-110.000	0.6719

S-Parameters (Vds = +3.3 V, 50% Idss, T = 22°C, de-embedded into package device in a 50 ohm system)

Freq (GHz)	S11 (Mag)	S11 (Ang)	S21 (dB)	S21 (Mag)	S21 (Ang)	S12 (Mag)	S12 (Ang)	S22 (Mag)	S22 (Ang)	K Value
0.05	0.998	-3.580	18.900	8.810	176.000	0.002	105.000	0.387	-3.780	-0.0299
0.30	0.994	-21.200	18.700	8.610	163.000	0.016	78.500	0.392	-16.300	0.0449
0.55	0.973	-39.900	18.547	8.460	149.000	0.030	66.900	0.360	-29.600	0.1249
0.80	0.935	-58.000	18.105	8.040	136.000	0.042	55.800	0.337	-42.100	0.2164
1.05	0.915	-74.200	17.696	7.670	123.000	0.052	46.900	0.317	-55.600	0.2394
1.30	0.880	-90.300	17.122	7.180	112.000	0.061	37.200	0.285	-67.900	0.3035
1.55	0.853	-105.000	16.547	6.720	100.000	0.068	28.700	0.259	-81.000	0.3513
1.80	0.826	-120.000	15.959	6.280	89.900	0.073	20.800	0.250	-93.100	0.3876
2.05	0.788	-136.000	15.402	5.890	79.700	0.080	14.000	0.236	-102.000	0.4513
2.30	0.772	-150.000	14.807	5.500	70.000	0.083	6.160	0.215	-115.000	0.4923
2.55	0.757	-163.000	14.185	5.120	60.800	0.087	-0.455	0.189	-126.000	0.5445
2.80	0.755	-175.000	13.625	4.800	52.000	0.089	-6.810	0.169	-138.000	0.5746
3.05	0.747	174.000	13.064	4.500	43.400	0.090	-13.400	0.150	-152.000	0.6242

Specifications and information are subject to change without notice.