

0.5A HIGH-SIDE DRIVER
INDUSTRIAL INTELLIGENT POWER SWITCH

PRELIMINARY DATA

- 0.5A OUTPUT CURRENT
- 18V TO 35V SUPPLY VOLTAGE RANGE
- INTERNAL CURRENT LIMITING
- THERMAL SHUTDOWN
- OPEN GROUND PROTECTION
- INTERNAL NEGATIVE VOLTAGE CLAMPING TO $V_s - 45V$ FOR FAST DEMAGNETIZATION
- DIFFERENTIAL INPUTS WITH LARGE COMMON MODE RANGE AND THRESHOLD HYSTERESIS
- UNDERVOLTAGE LOCKOUT WITH HYSTERESIS
- OPEN LOAD DETECTION
- TWO DIAGNOSTIC OUTPUTS
- OUTPUT STATUS LED DRIVER

MULTIPOWER BCD TECHNOLOGY

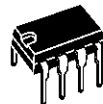

Minidip

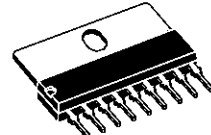

SIP9

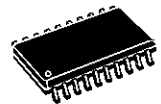

SO20

ORDERING NUMBERS:

TDE1897RDP
TDE1898RDP

TDE1898RSP

TDE1897RFP
TDE1898RFP

ogy, for driving inductive or resistive loads. An internal Clamping Diode enables the fast demagnetization of inductive loads.

Diagnostic for CPU feedback and extensive use of electrical protections make this device inherently indistructible and suitable for general purpose industrial applications.

DESCRIPTION

The TDE1897R/TDE1898R is a monolithic Intelligent Power Switch in Multipower BCD Technol-

BLOCK DIAGRAM

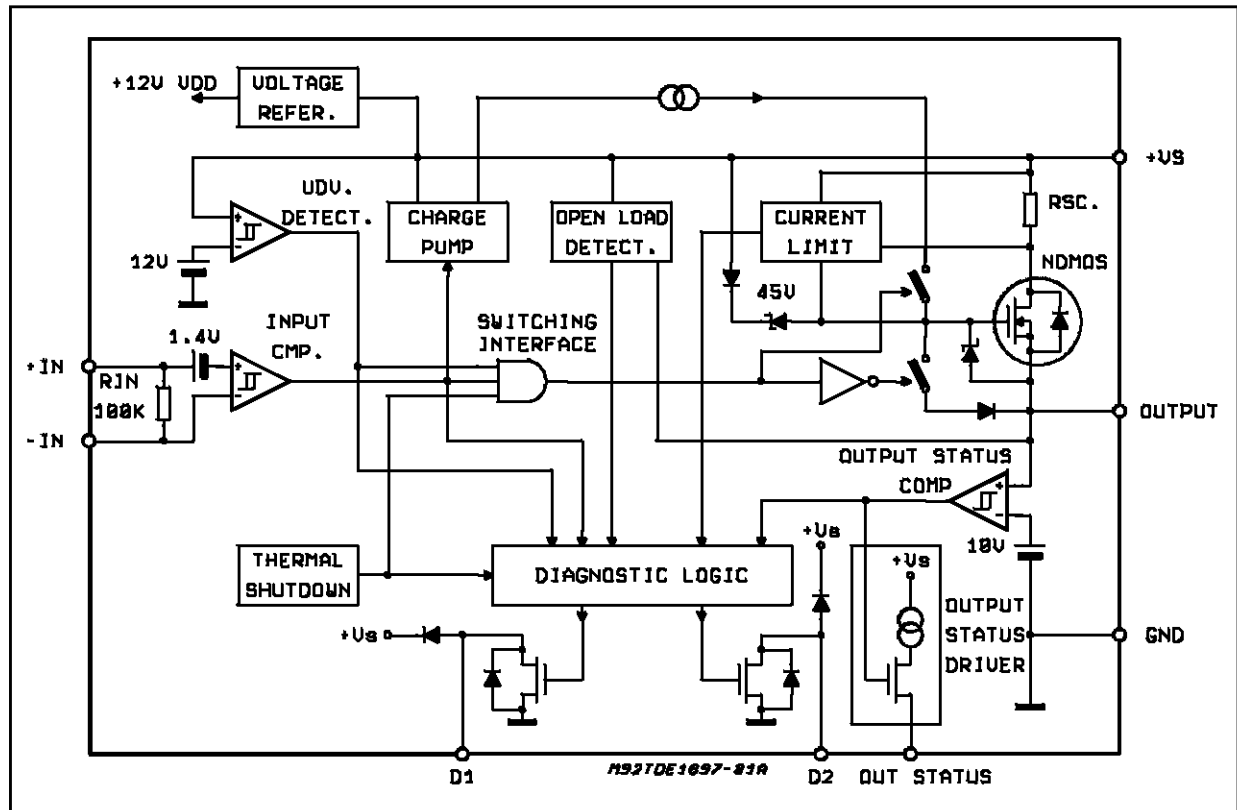

TDE1897R - TDE1898R

PIN CONNECTIONS (Top view)

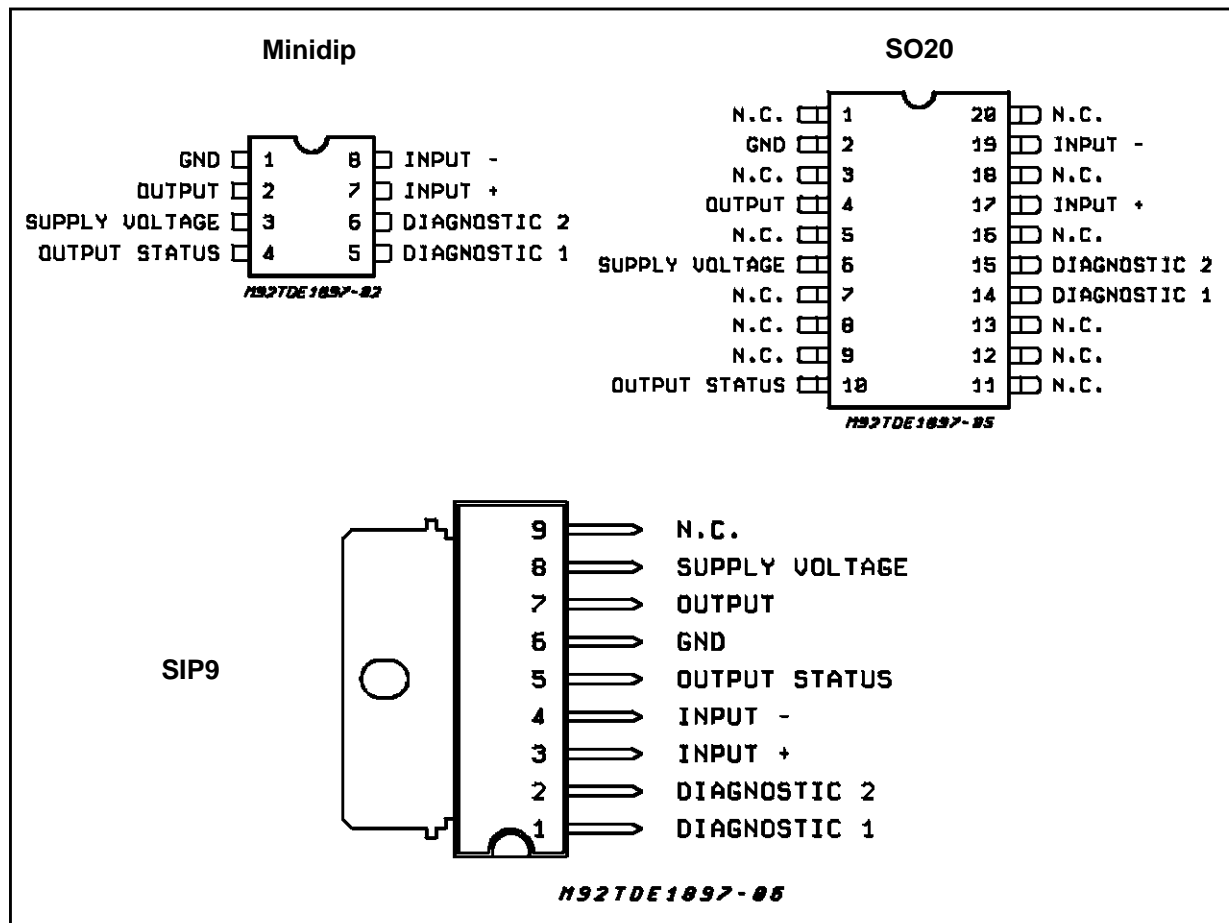

ABSOLUTE MAXIMUM RATINGS (Minidip pin reference)

Symbol	Parameter	Value	Unit
V_s	Supply Voltage (Pins 3 - 1) ($T_w < 10ms$)	50	V
$V_s - V_o$	Supply to Output Differential Voltage. See also V_{Cl} 3-2 (Pins 3 - 2)	internally limited	V
V_i	Input Voltage (Pins 7/8)	-10 to $V_s + 10$	V
V_i	Differential Input Voltage (Pins 7 - 8)	43	V
I_i	Input Current (Pins 7/8)	20	mA
I_o	Output Current (Pins 2 - 1). See also ISC	internally limited	A
E_l	Energy from Inductive Load ($T_J = 85^\circ C$)	200	mJ
P_{tot}	Power Dissipation. See also THERMAL CHARACTERISTICS.	internally limited	W
T_{op}	Operating Temperature Range (T_{amb})	-25 to +85	$^\circ C$
T_{stg}	Storage Temperature	-55 to 150	$^\circ C$

THERMAL DATA

Symbol	Description	Minidip	Sip	SO20	Unit	
$R_{th\ j-case}$	Thermal Resistance Junction-case	Max.	10		$^\circ C/W$	
$R_{th\ j-amb}$	Thermal Resistance Junction-ambient	Max.	100	70	90	$^\circ C/W$

ELECTRICAL CHARACTERISTICS ($V_S = 24V$; $T_{amb} = -25$ to $+85^\circ C$, unless otherwise specified)

Symbol	Parameter	Test Condition	Min.	Typ.	Max.	Unit
V_{smin} 3	Supply Voltage for Valid Diagnostics	$I_{diag} > 0.5mA$ @ $V_{dg1} = 1.5V$	9		35	V
V_S 3	Supply Voltage (operative)		18	24	35	V
I_q 3	Quiescent Current $I_{out} = I_{os} = 0$	V_{il} V_{ih}		2.5 4.5	4 7.5	mA mA
V_{sth1}	Undervoltage Threshold 1	(See fig. 1); $T_{amb} = 0$ to $+85^\circ C$	11			V
V_{sth2} 3	Undervoltage Threshold 2	(See fig. 1); $T_{amb} = 0$ to $+85^\circ C$			15.5	V
V_{shys}	Supply Voltage Hysteresis	(See fig. 1); $T_{amb} = 0$ to $+85^\circ C$	0.4	1	3	V
I_{sc}	Short Circuit Current	$V_S = 18$ to $35V$; $R_L = 1\Omega$	0.75		1.5	A
V_{don} 3-2	Output Voltage Drop	@ $I_{out} = 625mA$; $T_j = 25^\circ C$ @ $I_{out} = 625mA$; $T_j = 125^\circ C$		250 400	425 600	mV mV
I_{oslk} 2	Output Leakage Current	@ $V_i = V_{il}$, $V_o = 0V$			300	μA
V_{ol} 2	Low State Out Voltage	@ $V_i = V_{ih}$; $R_L = \infty$		0.8	1.5	V
V_{cl} 3-2	Internal Voltage Clamp ($V_S - V_O$)	@ $I_O = -500mA$	45		55	V
I_{old} 2	Open Load Detection Current	$V_i = V_{ih}$; $T_{amb} = 0$ to $+85^\circ C$	0.5		9.5	mA
V_{id} 7-8	Common Mode Input Voltage Range (Operative)	$V_S = 18$ to $35V$, $V_S - V_{id}$ 7-8 $< 37V$	-7		15	V
I_{ib} 7-8	Input Bias Current	$V_i = -7$ to $15V$; $-I_n = 0V$	-700		700	μA
V_{ith} 7-8	Input Threshold Voltage	$V+In > V-In$	0.8	1.4	2	V
V_{iths} 7-8	Input Threshold Hysteresis Voltage	$V+In > V-In$	50		400	mV
R_{id} 7-8	Diff. Input Resistance	@ $0 < +In < +16V$; $-In = 0V$ @ $-7 < +In < 0V$; $-In = 0V$		400 150		K Ω K Ω
I_{ilk} 7-8	Input Offset Current	$V+In = V-In$ +li -20 $0V < V_i < 5.5V$ -li -75		-25	+20	μA μA
		$-In = GND$ +li +10 $0V < V+In < 5.5V$ -li -250		-125	+50	μA μA
		$+In = GND$ +li -100 $0V < V-In < 5.5V$ -li -50		-15		μA μA
V_{oth1} 2	Output Status Threshold 1 Voltage	(See fig. 1)			12	V
V_{oth2} 2	Output Status Threshold 2 Voltage	(See fig. 1)	9			V
V_{ohys} 2	Output Status Threshold Hysteresis	(See fig. 1)	0.3	0.7	2	V
I_{osd} 4	Output Status Source Current	$V_{out} > V_{oth1}$, $V_{os} = 2.5V$	2		4	mA
V_{osd} 3-4	Active Output Status Driver Drop Voltage	$V_S - V_{os}$ @ $I_{os} = 2mA$; $T_{amb} = -25$ to $85^\circ C$			5	V
I_{oslk} 4	Output Status Driver Leakage Current	$V_{out} < V_{oth2}$, $V_{os} = 0V$ $V_S = 18$ to $35V$			25	μA
V_{dgl} 5/6	Diagnostic Drop Voltage	$D1 / D2 = L$ @ $I_{diag} = 0.5mA$			250	mV
		$D1 / D2 = L$ @ $I_{diag} = 3mA$			1.5	V
I_{dglk} 5/6	Diagnostic Leakage Current	$D1 / D2 = H$ @ $0 < V_{dg} < V_S$ $V_S = 15.6$ to $35V$			25	μA
V_{fdg} 5/6-3	Clamping Diodes at the Diagnostic Outputs. Voltage Drop to V_S	@ $I_{diag} = 5mA$; $D1 / D2 = H$			2	V

Note $V_{il} \leq 0.8V$, $V_{ih} \geq 2V$ @ ($V+In > V-In$); Minidip pin reference.
All test not dissipative.

TDE1897R - TDE1898R

SOURCE DRAIN NDMOS DIODE

Symbol	Parameter	Test Condition	Min.	Typ.	Max.	Unit
V_{fSD} 2-3	Forward On Voltage	@ $I_{fSD} = 625mA$		1	1.5	V
I_{fp} 2-3	Forward Peak Current	$t = 10ms; d = 20\%$			2	A
t_{rr} 2-3	Reverse Recovery Time	$I_f = 625mA$ $di/dt = 25A/\mu s$		200		ns
t_{fr} 2-3	Forward Recovery Time			50		ns

THERMAL CHARACTERISTICS (*)

Θ_{Lim}	Junction Temp. Protect.		135	150		°C
T_H	Thermal Hysteresis			30		°C

SWITCHING CHARACTERISTICS ($V_S = 24V; R_L = 48\Omega$) (*)

t_{on}	Turn on Delay Time				100	μs
t_{off}	Turn off Delay Time				20	μs
t_d	Input Switching to Diagnostic Valid				100	μs

Note $V_{il} \leq 0.8V, V_{ih} \geq 2V$ @ ($V_{in} > V_{-In}$); Minidip pin reference. (*) Not tested.

Figure 1

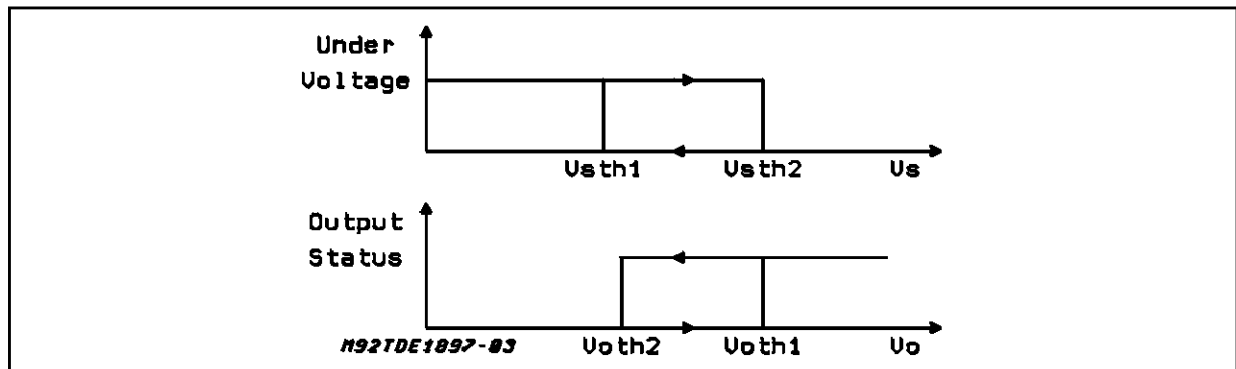

DIAGNOSTIC TRUTH TABLE

Diagnostic Conditions	Input	Output	Diag1	Diag2
Normal Operation	L	L	H	H
	H	H	H	H
Open Load Condition ($I_o < I_{old}$)	L	L	H	H
	H	H	L	H
Short to V_S	L	H	L	H
	H	H	L	H
Short Circuit to Ground ($I_o = I_{sc}$) (**)	TDE1897R	H	<H (*)	L
	TDE1898R	H	H	H
Output DMOS Open	L	L	H	H
	H	L	L	H
Overtemperature	L	L	H	L
	H	L	H	L
Supply Undervoltage ($V_S < V_{sth1}$ in the falling phase of the supply voltage; $V_S < V_{sth2}$ in the rising phase of the supply voltage)	L	L	L	L
	H	L	L	L

(*) According to the intervention of the current limiting block.

(**) A cold lamp filament, or a capacitive load may activate the current limiting circuit of the IPS, when the IPS is initially turned on. TDE1897 uses Diag2 to signal such condition, TDE1898 does not.

APPLICATION INFORMATION

DEMAGNETIZATION OF INDUCTIVE LOADS

An internal zener diode, limiting the voltage across the Power MOS to between 45 and 55V (V_{cl}), provides safe and fast demagnetization of inductive loads without external clamping devices.

The maximum energy that can be absorbed from an inductive load is specified as 200mJ (at $T_j = 85^\circ\text{C}$).

To define the maximum switching frequency three points have to be considered:

- 1) The total power dissipation is the sum of the On State Power and of the Demagnetization Energy multiplied by the frequency.
- 2) The total energy W dissipated in the device during a demagnetization cycle (fig. 2, 3) is:

$$W = V_{cl} \frac{L}{R_L} \left[I_o - \frac{V_{cl} - V_s}{R_L} \log \left(1 + \frac{V_s}{V_{cl} - V_s} \right) \right]$$

Where:

- V_{cl} = clamp voltage;
- L = inductive load;
- R_L = resistive load;
- V_s = supply voltage;
- $I_o = I_{LOAD}$

- 3) In normal conditions the operating Junction temperature should remain below 125°C .

Figure 3: Demagnetization Cycle Waveforms

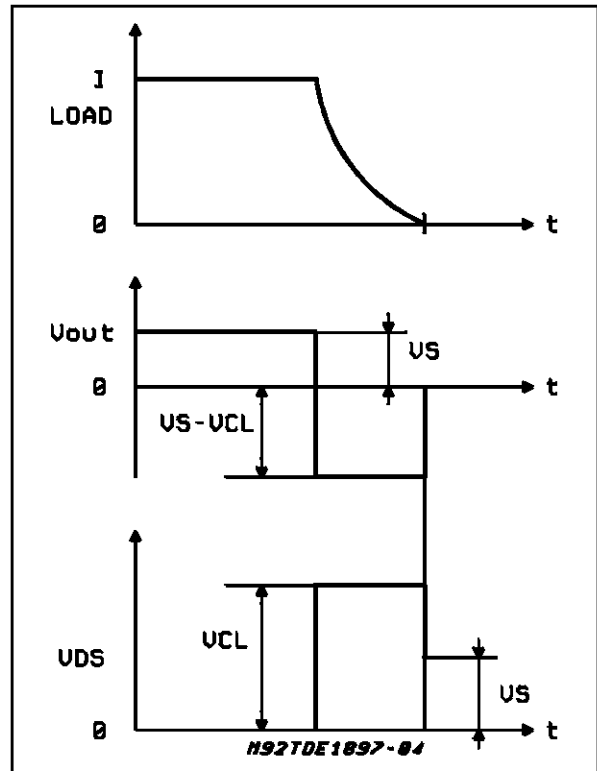

Figure 2: Inductive Load Equivalent Circuit

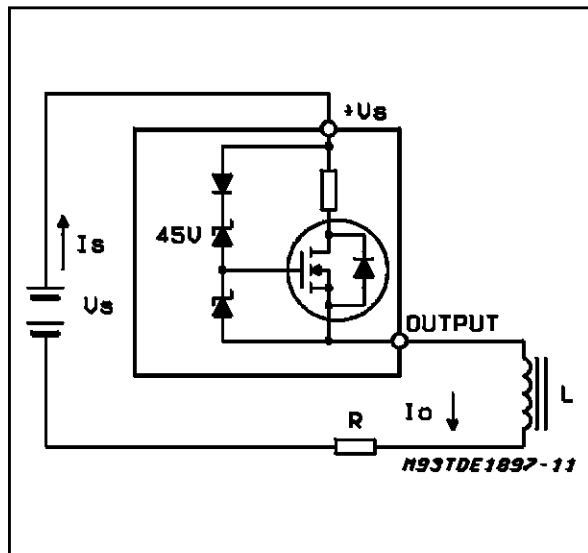
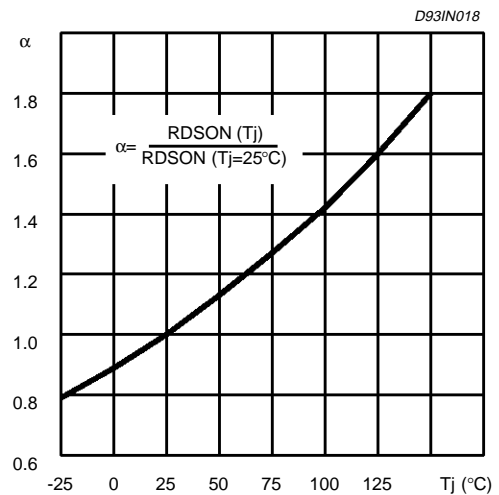

Figure 4: Normalized $R_{DS(on)}$ vs. Junction Temperature



WORST CONDITION POWER DISSIPATION IN THE ON-STATE

In IPS applications the maximum average power dissipation occurs when the device stays for a long time in the ON state. In such a situation the internal temperature depends on delivered current (and related power), thermal characteristics of the package and ambient temperature.

At ambient temperature close to upper limit (+85°C) and in the worst operating conditions, it is possible that the chip temperature could increase so much to make the thermal shutdown procedure untimely intervene.

Our aim is to find the maximum current the IPS can withstand in the ON state without thermal shutdown intervention, related to ambient temperature. To this end, we should consider the following points:

- 1) The ON resistance $R_{DS(on)}$ of the output NDMOS (the real switch) of the device increases with its temperature. Experimental results show that silicon resistivity increases with temperature at a constant rate, rising of 60% from 25°C to 125°C. The relationship between $R_{DS(on)}$ and temperature is therefore:

$$R_{DS(on)} = R_{DS(on)0} (1 + k) (T_j \pm 25)$$

where:

- T_j is the silicon temperature in °C
- $R_{DS(on)0}$ is $R_{DS(on)}$ at $T_j=25^\circ\text{C}$
- k is the constant rate ($k = 4.711 \cdot 10^{-3}$) (see fig. 4).

- 2) In the ON state the power dissipated in the device is due to three contributes:
 - a) power lost in the switch:
 $P_{out} = I_{out}^2 \cdot R_{DS(on)}$ (I_{out} is the output current);
 - b) power due to quiescent current in the ON state I_q , sunk by the device in addition to I_{out} : $P_q = I_q \cdot V_s$ (V_s is the supply voltage);
 - c) an external LED could be used to visualize the switch state (OUTPUT STATUS pin). Such a LED is driven by an internal current source (delivering I_{os}) and therefore, if V_{os} is the voltage drop across the LED, the dissipated power is: $P_{os} = I_{os} \cdot (V_s \pm V_{os})$.

Thus the total ON state power consumption is given by:

$$P_{on} = P_{out} + P_q + P_{os} \quad (1)$$

In the right side of equation 1, the second and

the third element are constant, while the first one increases with temperature because $R_{DS(on)}$ increases as well.

- 3) The chip temperature must not exceed Θ_{Lim} in order do not lose the control of the device. The heat dissipation path is represented by the thermal resistance of the system device-board-ambient (R_{th}). In steady state conditions, this parameter relates the power dissipated P_{on} to the silicon temperature T_j and the ambient temperature T_{amb} :

$$T_j \pm T_{amb} = P_{on} \cdot R_{th} \quad (2)$$

From this relationship, the maximum power P_{on} which can be dissipated without exceeding Θ_{Lim} at a given ambient temperature T_{amb} is:

$$P_{on} = \frac{\Theta_{Lim} \pm T_{amb}}{R_{th}}$$

Replacing the expression (1) in this equation and solving for I_{out} , we can find the maximum current versus ambient temperature relationship:

$$I_{outx} = \sqrt{\frac{\Theta_{Lim} \pm T_{amb} \pm P_q \pm P_{os}}{R_{th} \cdot R_{DS(on)x}}}$$

where $R_{DS(on)x}$ is $R_{DS(on)}$ at $T_j=\Theta_{Lim}$. Of course, I_{outx} values are top limited by the maximum operative current I_{outx} (500mA nominal).

From the expression (2) we can also find the maximum ambient temperature T_{amb} at which a given power P_{on} can be dissipated:

$$T_{amb} = \Theta_{Lim} \pm P_{on} \cdot R_{th} = \Theta_{Lim} \pm (I_{out}^2 \cdot R_{DS(on)x} + P_q + P_{os}) \cdot R_{th}$$

In particular, this relation is useful to find the maximum ambient temperature T_{ambx} at which I_{outx} can be delivered:

$$T_{ambx} = \Theta_{Lim} \pm (I_{outx}^2 \cdot R_{DS(on)x} + P_q + P_{os}) \cdot R_{th} \quad (4)$$

Referring to application circuit in fig. 5, let us consider the worst case:

- The supply voltage is at maximum value of industrial bus (30V instead of the 24V nominal value). This means also that I_{outx} rises of 25%

(625mA instead of 500mA).

- All electrical parameters of the device, concerning the calculation, are at maximum values.
- Thermal shutdown threshold is at minimum value.
- No heat sink nor air circulation (R_{th} equal to $R_{thj-amb}$).

Therefore:

$V_s = 30V$, $R_{DS(ON)0} = 0.6\Omega$, $I_q = 6mA$, $I_{os} = 4mA$ @ $V_{os} = 2.5V$, $\Theta_{Lim} = 135^\circ C$

$R_{thj-amb} = 100^\circ C/W$ (Minidip); $90^\circ C/W$ (SO20); $70^\circ C/W$ (SIP9)

It follows:

$I_{outx} = 0.625mA$, $R_{DS(ON)x} = 1.006\Omega$, $P_q = 180mW$, $P_{os} = 110mW$

From equation 4, we can find:

$$T_{ambx} = \begin{matrix} 66.7^\circ C & (\text{Minidip}); \\ 73.5^\circ C & (\text{SO20}); \\ 87.2^\circ C & (\text{SIP9}). \end{matrix}$$

Therefore, the IPS TDE1897/1898, although guaranteed to operate up to $85^\circ C$ ambient temperature, if used in the worst conditions, can meet some limitations.

SIP9 package, which has the lowest $R_{thj-amb}$, can work at maximum operative current over the entire ambient temperature range in the worst conditions too. For other packages, it is necessary to consider some reductions.

With the aid of equation 3, we can draw a derating curve giving the maximum current allowable versus ambient temperature. The diagrams, computed using parameter values above given, are depicted in figg. 6 to 8.

If an increase of the operating area is needed, heat dissipation must be improved (R_{th} reduced) e.g. by means of air cooling.

Figure 5: Application Circuit.

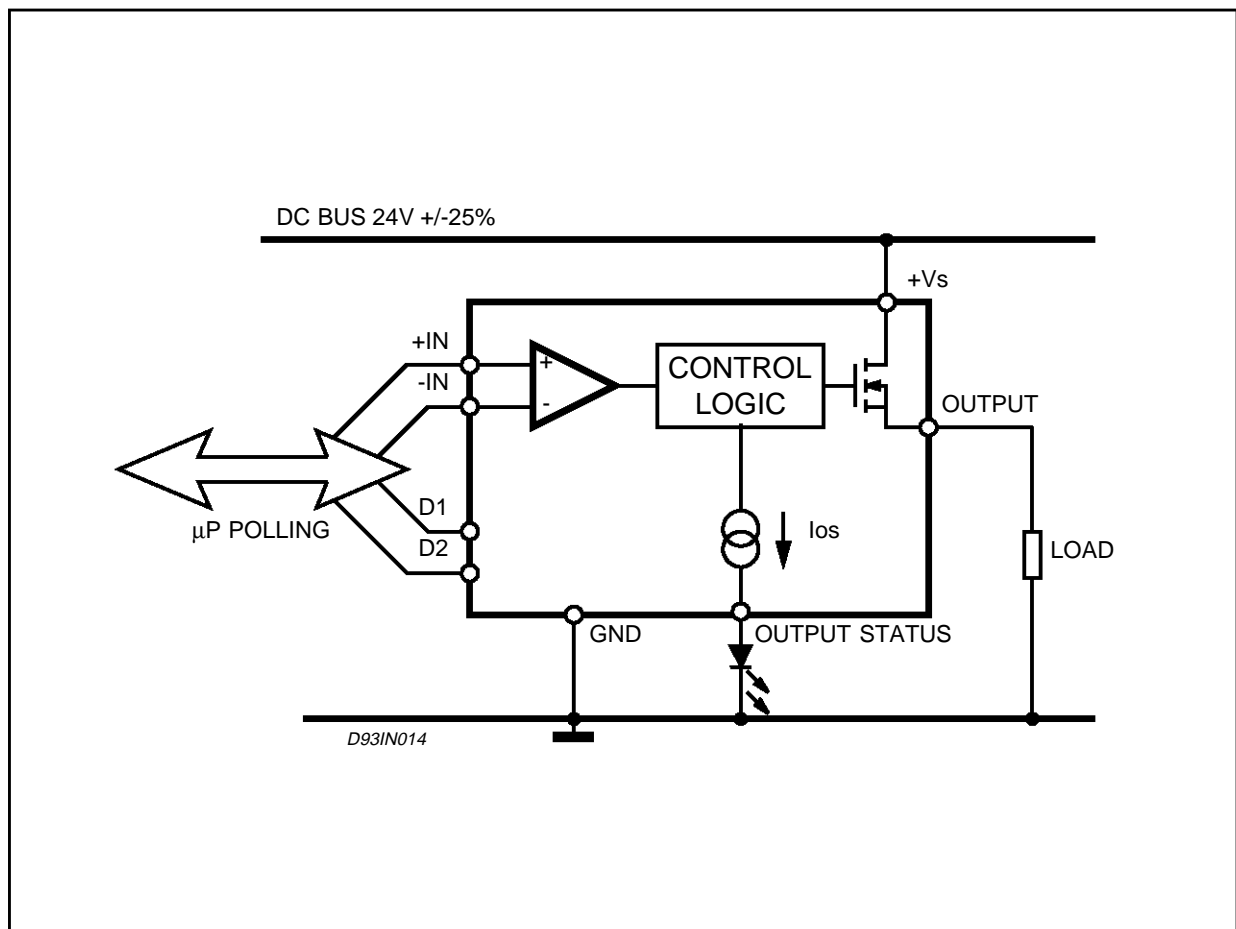

Figure 6: Max. Output Current vs. Ambient Temperature (Minidip Package, $R_{th\ j-amb} = 100^{\circ}C/W$)

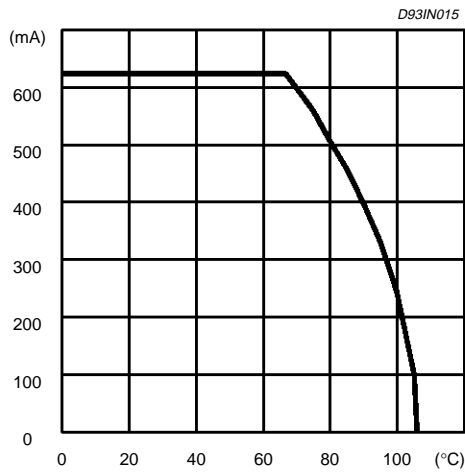

Figure 7: Max. Output Current vs. Ambient Temperature (SO20 Package, $R_{th\ j-amb} = 90^{\circ}C/W$)

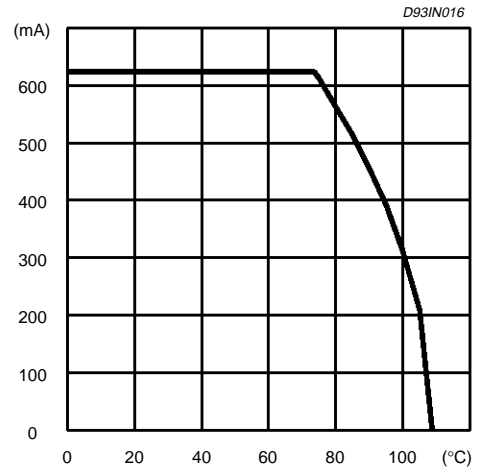
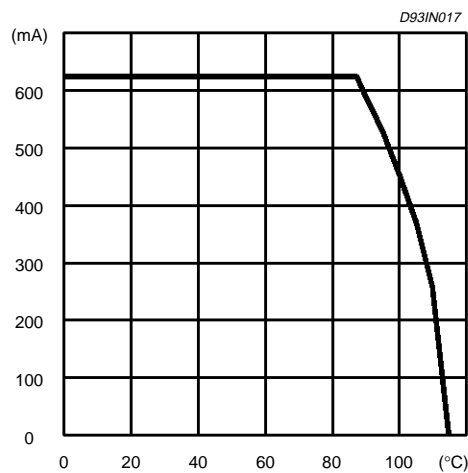
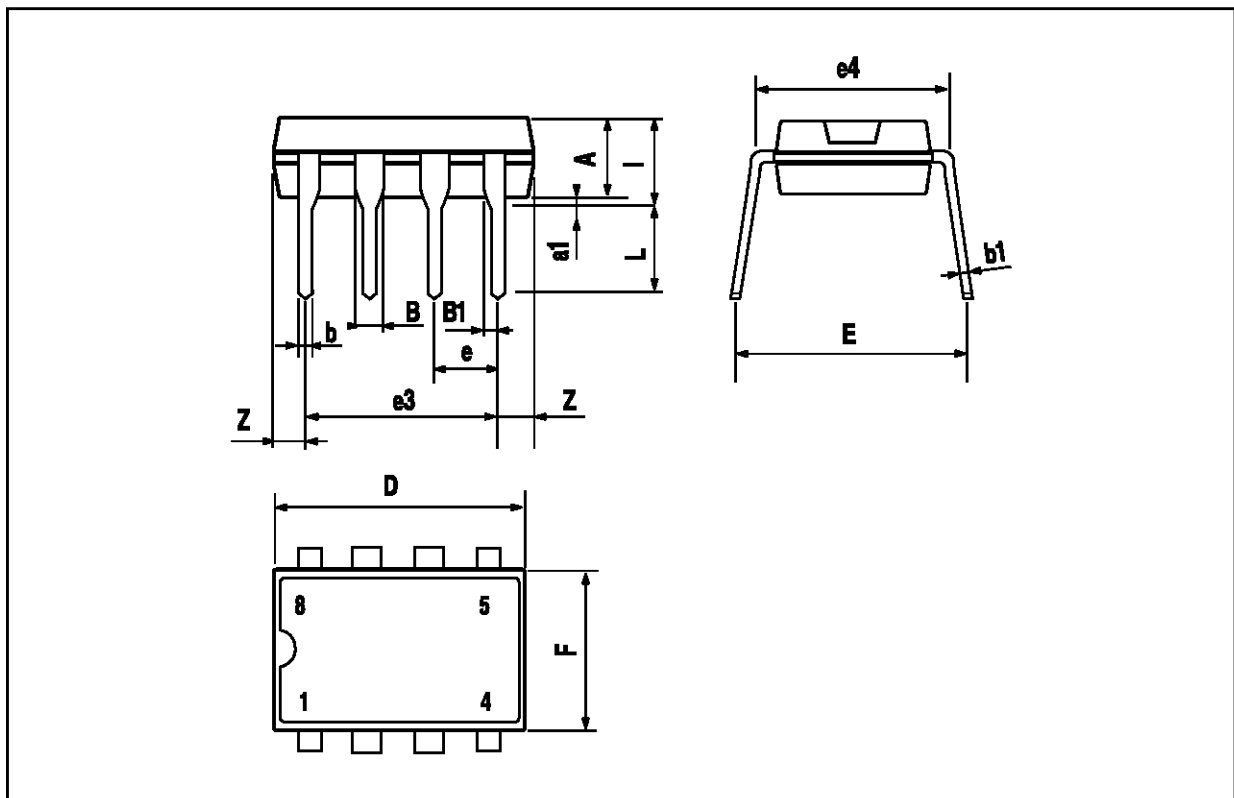

Figure 8: Max. Output Current vs. Ambient Temperature (SIP9 Package, $R_{th\ j-amb} = 70^{\circ}C/W$)



MINIDIP PACKAGE MECHANICAL DATA

DIM	mm			inch		
	Min.	Typ.	Max.	Min.	Typ.	Max.
A		3.32			0.131	
a1	0.51			0.020		
B	1.15		1.65	0.045		0.065
b	0.356		0.55	0.014		0.022
b1	0.204		0.304	0.008		0.012
D			10.92			0.430
E	7.95		9.75	0.313		0.384
e		2.54			0.100	
e3		7.62			0.300	
e4		7.62			0.300	
F			6.6			0.260
i			5.08			0.200
L	3.18		3.81	0.125		0.150
Z			1.52			0.060



SIP9 PACKAGE MECHANICAL DATA

DIM.	mm			inch		
	MIN.	TYP.	MAX.	MIN.	TYP.	MAX.
A			7.1			0.280
a1	2.7		3	0.106		0.118
B			23			0.90
B3			24.8			0.976
b1		0.5			0.020	
b3	0.85		1.6	0.033		0.063
C		3.3			0.130	
c1		0.43			0.017	
c2		1.32			0.052	
D			21.2			0.835
d1		14.5			0.571	
e		2.54			0.100	
e3		20.32			0.800	
L	3.1			0.122		
L1		3			0.118	
L2		17.6			0.693	
L3			0.25			0.010
L4	17.4		17.85	0.685		0,702
M		3.2			0.126	
N		1			0.039	
P			0.15			0.006

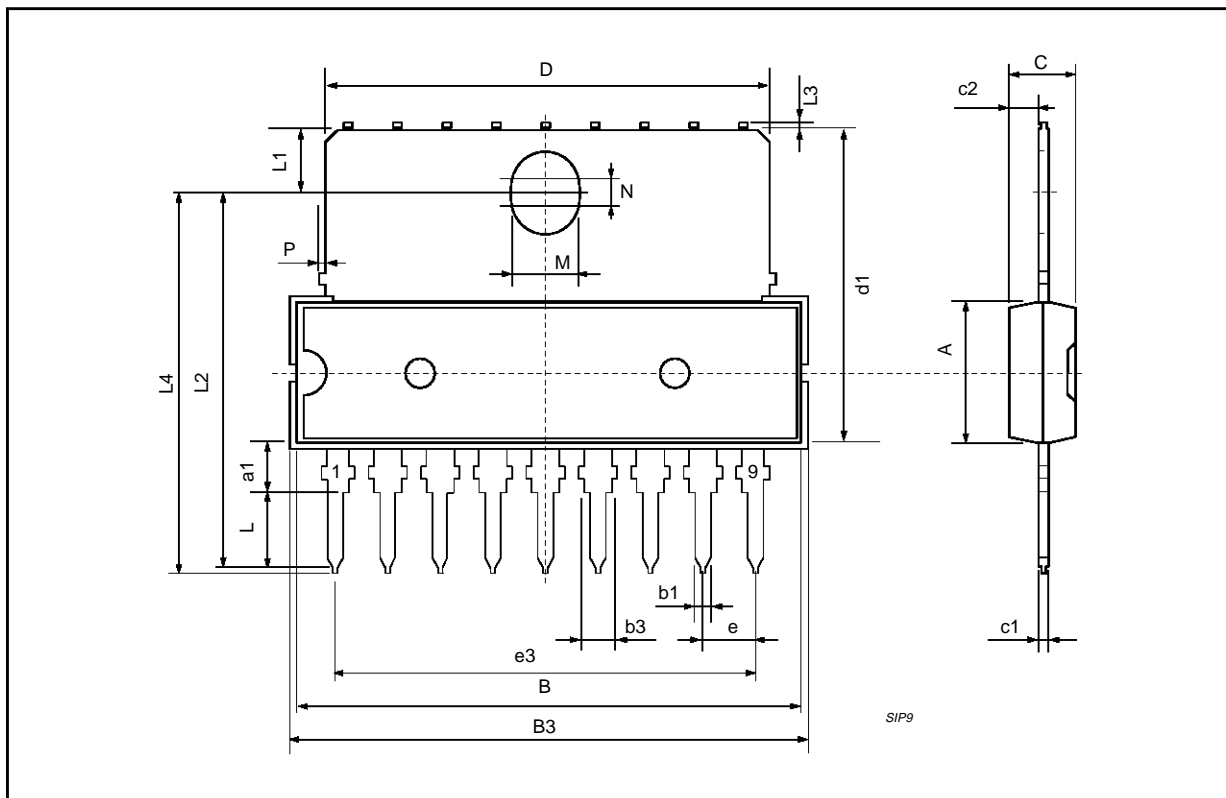

SO20 PACKAGE MECHANICAL DATA

DIM.	mm			inch		
	MIN.	TYP.	MAX.	MIN.	TYP.	MAX.
A			2.65			0.104
a1	0.1		0.2	0.004		0.008
a2			2.45			0.096
b	0.35		0.49	0.014		0.019
b1	0.23		0.32	0.009		0.013
C		0.5			0.020	
c1	45° (typ.)					
D	12.6		13.0	0.496		0.510
E	10		10.65	0.394		0.419
e		1.27			0.050	
e3		11.43			0.450	
F	7.4		7.6	0.291		0.300
L	0.5		1.27	0.020		0.050
M			0.75			0.030
S	8° (max.)					

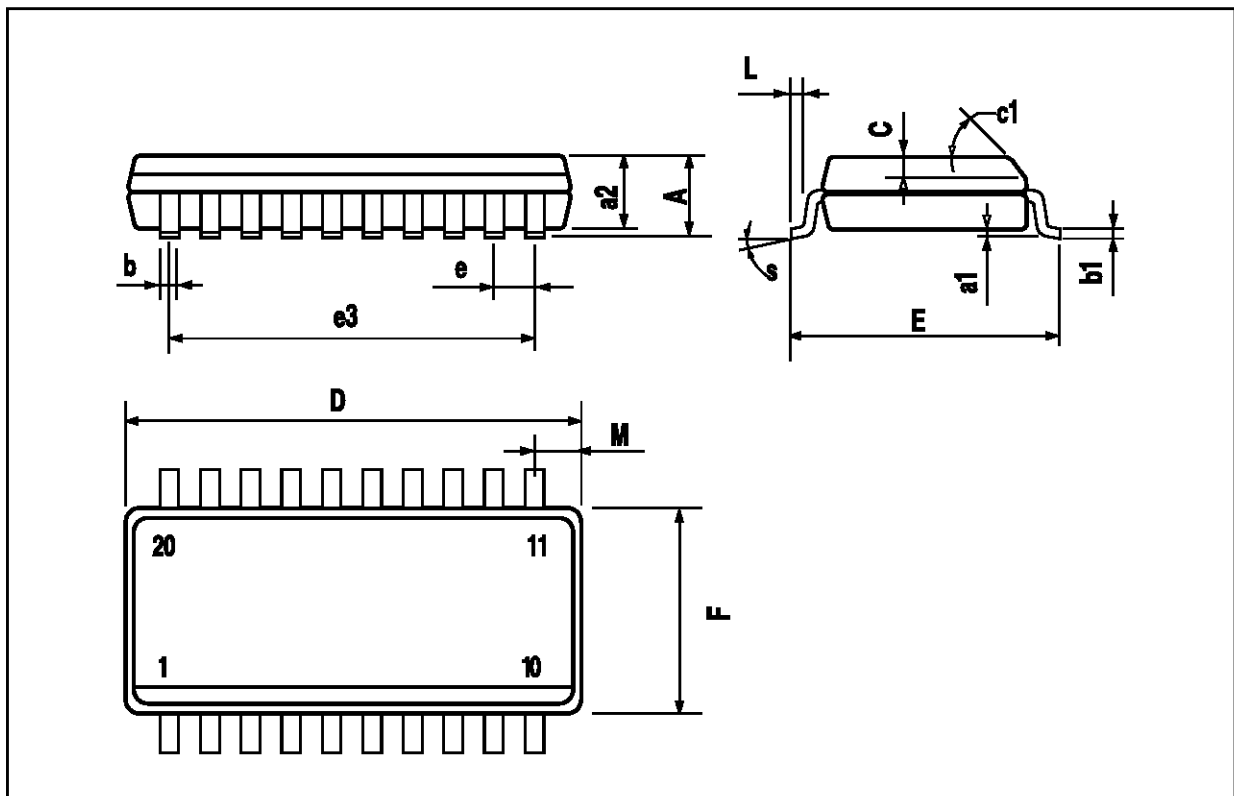

Information furnished is believed to be accurate and reliable. However, SGS-THOMSON Microelectronics assumes no responsibility for the consequences of use of such information nor for any infringement of patents or other rights of third parties which may result from its use. No license is granted by implication or otherwise under any patent or patent rights of SGS-THOMSON Microelectronics. Specification mentioned in this publication are subject to change without notice. This publication supersedes and replaces all information previously supplied. SGS-THOMSON Microelectronics products are not authorized for use as critical components in life support devices or systems without express written approval of SGS-THOMSON Microelectronics.

© 1995 SGS-THOMSON Microelectronics – Printed in Italy – All Rights Reserved

SGS-THOMSON Microelectronics GROUP OF COMPANIES
Australia - Brazil - Canada - China - France - Germany - Hong Kong - Italy - Japan - Korea - Malaysia - Malta - Morocco - The Netherlands -
Singapore - Spain - Sweden - Switzerland - Taiwan - Thailand - United Kingdom - U.S.A.