



STGW30NC120HD

N-CHANNEL 30A - 1200V - TO-247
VERY FAST PowerMESH™ IGBT

TARGET SPECIFICATION

General features

Type	V _{CES}	V _{CE(sat)} (Max) @ 25°C	I _C
STGW30NC120HD	1200V	< 2.8V	30A

- LOW ON-LOSSES
- LOW ON-VOLTAGE DROP (V_{cesat})
- HIGH CURRENT CAPABILITY
- HIGH INPUT IMPEDANCE (VOLTAGE DRIVEN)
- LOW GATE CHARGE
- VERY HIGH FREQUENCY OPERATION
- LATCH CURRENT FREE OPERATION

Description

Using the latest high voltage technology based on its patented strip layout, STMicroelectronics has designed an advanced family of IGBTs, with outstanding performances. The suffix "H" identifies a family optimized for high frequency application in order to achieve very high switching performances (reduced t_{fall}) maintaining a low voltage drop.

Applications

- HIGH FREQUENCY MOTOR CONTROL
- U.P.S
- WELDING EQUIPMENT
- INDUCTION HEATING

Order codes

Sales Type	Marking	Package	Packaging
STGW30NC120HD	GW30NC120HD	TO-247	TUBE

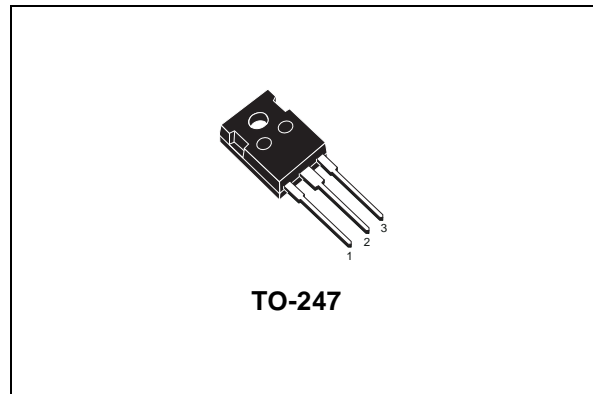

Internal schematic diagram

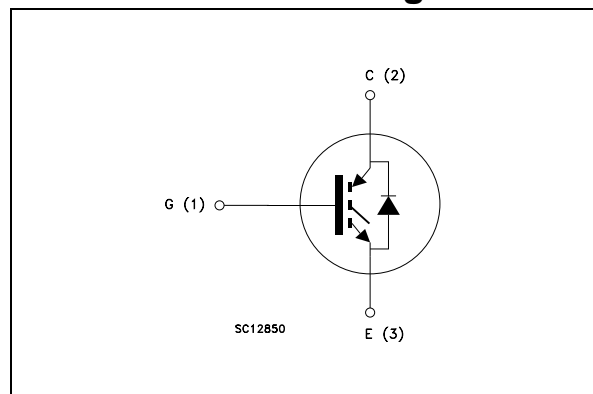

1 Electrical ratings

Table 1. Absolute maximum ratings

Symbol	Parameter	Value	Unit
V_{CES}	Collector-Emitter Voltage ($V_{GS} = 0$)	1200	V
I_C <i>Note 2</i>	Collector Current (continuous) at 25°C	60	A
I_C <i>Note 2</i>	Collector Current (continuous) at 100°C	30	A
I_{CM} <i>Note 1</i>	Collector Current (pulsed)	120	A
V_{GE}	Gate-Emitter Voltage	± 20	V
P_{TOT}	Total Dissipation at $T_C=25^\circ\text{C}$	200	W
I_f	Diode RMS Forward Current at $T_C=25^\circ\text{C}$	200	
T_j	Operating Junction Temperature	– 55 to 150	°C
T_{stg}	Storage Temperature		

Table 2. Thermal resistance

		Min.	Typ.	Max.	Unit
Rthj-case	Thermal Resistance Junction-case	--	--	0.625	°C/W
Rthj-amb	Thermal Resistance Junction-ambient	--	--	50	°C/W

2 Electrical characteristics

($T_{CASE} = 25\text{ °C}$ unless otherwise specified)

Table 3. Static

Symbol	Parameter	Test Conditions	Min.	Typ.	Max.	Unit
$V_{BR(CES)}$	Collectro-Emitter Breakdown Voltage	$I_C = 250\mu A, V_{GE} = 0$	1200			V
$V_{CE(SAT)}$	Collector-Emitter Saturation Voltage	$V_{GE} = 15V, I_C = 20A, T_j = 25\text{ °C}$ $V_{GE} = 15V, I_C = 20A, T_j = 125\text{ °C}$		2.4 2	2.9	V V
$V_{GE(th)}$	Gate Threshold Voltage	$V_{CE} = V_{GE}, I_C = 250\mu A$	5		7	V
I_{CES}	Collector-Emitter Leakage Current ($V_{CE} = 0$)	$V_{GE} = \text{Max Rating}, T_c = 25\text{ °C}$ $V_{GE} = \text{Max Rating}, T_c = 125\text{ °C}$			10 100	μA μA
I_{GES}	Gate-Emitter Leakage Current ($V_{CE} = 0$)	$V_{GE} = \pm 20V, V_{CE} = 0$			± 100	nA
g_{fs}	Forward Transconductance	$V_{CE} = 25V, I_C = 25A$		TBD		S

Table 4. Dynamic

Symbol	Parameter	Test Conditions	Min.	Typ.	Max.	Unit
C_{ies}	Input Capacitance	$V_{CE} = 25V, f = 1\text{ MHz}, V_{GE} = 0$		TBD		pF
C_{oes}	Output Capacitance			TBD		pF
C_{res}	Reverse Transfer Capacitance			TBD		pF
Qg	Total Gate Charge	$V_{CE} = 960V, I_C = 20A, V_{GE} = 15V$		TBD	TBD	nC
Qge	Gate-Emitter Charge			TBD		nC
Qgc	Gate-Collector Charge			TBD		nC

Table 5. Switching on/off (inductive load)

Symbol	Parameter	Test Conditions	Min.	Typ.	Max.	Unit
$t_{d(on)}$ t_r $(di/dt)_{on}$	Turn-on Delay Time Current Rise Time Turn-on Current Slope	$V_{CC} = 960V, I_C = 20A$ $R_G = 10\Omega, V_{GE} = 15V, T_j = 25^\circ C$ (see Figure 3)		TBD 62 TBD		ns ns A/ μs
$t_{d(on)}$ t_r $(di/dt)_{on}$	Turn-on Delay Time Current Rise Time Turn-on Current Slope	$V_{CC} = 960V, I_C = 20A$ $R_G = 10\Omega, V_{GE} = 15V, T_j = 125^\circ C$ (see Figure 3)		TBD TBD TBD		ns ns A/ μs
$t_r(V_{off})$ $t_{d(off)}$ t_f	Off Voltage Rise Time Turn-off Delay Time Current Fall Time	$V_{CC} = 960V, I_C = 20A$ $R_G = 10\Omega, V_{GE} = 15V, T_j = 25^\circ C$ (see Figure 3)		TBD TBD TBD		ns ns ns
$t_r(V_{off})$ $t_{d(off)}$ t_f	Cross-over Time Off Voltage Rise Time Turn-off Delay Time Current Fall Time	$V_{CC} = 960V, I_C = 20A$ $R_G = 10\Omega, V_{GE} = 15V, T_j = 125^\circ C$ (see Figure 3)		TBD TBD TBD		ns ns ns

Table 6. Switching energy (inductive load)

Symbol	Parameter	Test Conditions	Min.	Typ.	Max.	Unit
E_{on} <i>Note 3</i> E_{off} <i>Note 4</i> E_{ts}	Turn-on Switching Losses Turn-off Switching Losses Total Switching Losses	$V_{CC} = 960V, I_C = 20A$ $R_G = 10\Omega, V_{GE} = 15V, T_j = 25^\circ C$ (see Figure 3)		TBD TBD TBD		μJ μJ μJ
E_{on} <i>Note 3</i> E_{off} <i>Note 4</i> E_{ts}	Turn-on Switching Losses Turn-off Switching Losses Total Switching Losses	$V_{CC} = 960V, I_C = 20A$ $R_G = 10\Omega, V_{GE} = 15V, T_j = 125^\circ C$ (see Figure 3)		TBD TBD TBD		μJ μJ μJ

Table 7. Collector-emitter diode

Symbol	Parameter	Test Conditions	Min.	Typ.	Max.	Unit
V_f	Forward On-Voltage	$I_f = 12A$ $I_f = 12A, T_j = 125^\circ C$		2.4 1.4	2.9	V V
t_{rr} Q_{rr} I_{rrm}	Reverse Recovery Time Reverse Recovery Charge Reverse Recovery Current	$I_f = 12A, V_R = 27V,$ $T_j = 125^\circ C, di/dt = 100A/\mu s$ (see Figure 4)		TBD TBD TBD		ns nC A

(1) Pulse width limited by max junction temperature

(2) Calculated according to the iterative formula:

$$I_C(T_C) = \frac{T_{JMAX} - T_C}{R_{THJ-C} \times V_{CESAT(MAX)}(T_C, I_C)}$$

(3) E_{on} is the turn-on losses when a typical diode is used in the test circuit in figure 2. If the IGBT is offered in a package with a co-pack diode, the co-pack diode is used as external diode. IGBTs & Diode are at the same temperature (25°C and 125°C)

(4) Turn-off losses include also the tail of the collector current

3 Test Circuits

Figure 1. Test Circuit for Inductive Load Switching

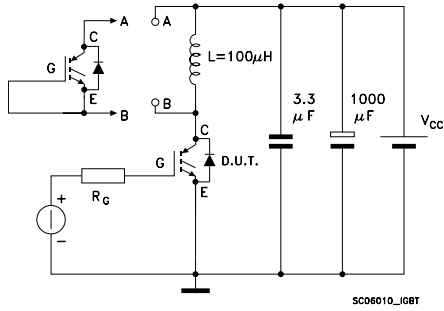

Figure 2. Gate Charge Test Circuit

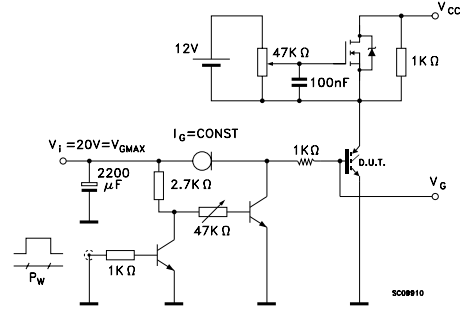

Figure 3. Switching Waveform

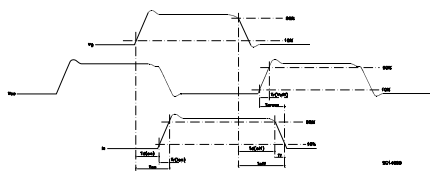
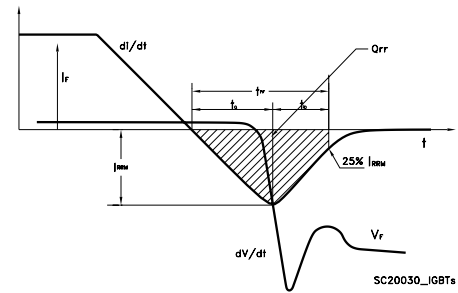

Figure 4. Diode Recovery Time Waveform



4 Package mechanical data

In order to meet environmental requirements, ST offers these devices in ECOPACK® packages. These packages have a Lead-free second level interconnect . The category of second level interconnect is marked on the package and on the inner box label, in compliance with JEDEC Standard JESD97. The maximum ratings related to soldering conditions are also marked on the inner box label. ECOPACK is an ST trademark. ECOPACK specifications are available at: www.st.com

TO-247 MECHANICAL DATA

DIM.	mm.			inch		
	MIN.	TYP	MAX.	MIN.	TYP.	MAX.
A	4.85		5.15	0.19		0.20
A1	2.20		2.60	0.086		0.102
b	1.0		1.40	0.039		0.055
b1	2.0		2.40	0.079		0.094
b2	3.0		3.40	0.118		0.134
c	0.40		0.80	0.015		0.03
D	19.85		20.15	0.781		0.793
E	15.45		15.75	0.608		0.620
e		5.45			0.214	
L	14.20		14.80	0.560		0.582
L1	3.70		4.30	0.14		0.17
L2		18.50			0.728	
øP	3.55		3.65	0.140		0.143
øR	4.50		5.50	0.177		0.216
S		5.50			0.216	

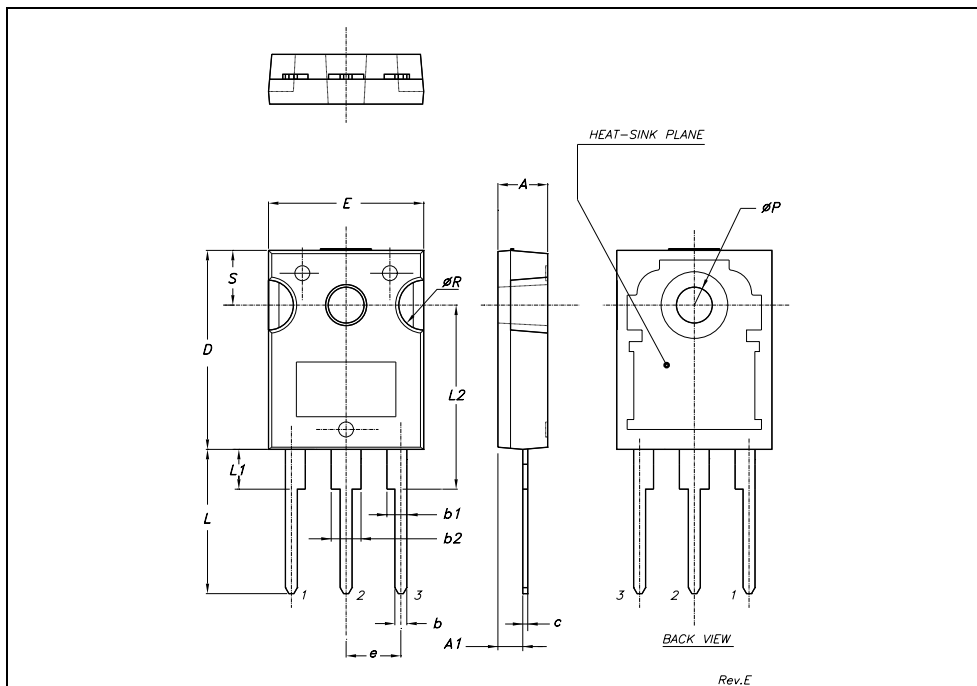

5 Revision History

Date	Revision	Changes
14-Nov-2005	1	Initial release.

Information furnished is believed to be accurate and reliable. However, STMicroelectronics assumes no responsibility for the consequences of use of such information nor for any infringement of patents or other rights of third parties which may result from its use. No license is granted by implication or otherwise under any patent or patent rights of STMicroelectronics. Specifications mentioned in this publication are subject to change without notice. This publication supersedes and replaces all information previously supplied. STMicroelectronics products are not authorized for use as critical components in life support devices or systems without express written approval of STMicroelectronics.

The ST logo is a registered trademark of STMicroelectronics.
All other names are the property of their respective owners

© 2005 STMicroelectronics - All rights reserved

STMicroelectronics group of companies

Australia - Belgium - Brazil - Canada - China - Czech Republic - Finland - France - Germany - Hong Kong - India - Israel - Italy - Japan -
Malaysia - Malta - Morocco - Singapore - Spain - Sweden - Switzerland - United Kingdom - United States of America

www.st.com

