



LIS302DL: 3-Axis - $\pm 2g/\pm 8g$ digital output ultracompact linear accelerometer

Introduction

This document is intended to give application notes for the low-voltage 3-axis digital output linear MEMS accelerometer provided in LGA package.

The LIS302DL is an ultra compact low-power three axes linear accelerometer that includes a sensing element and an IC interface able to take the information from the sensing element and to provide the measured acceleration to the external world through I²C/SPI serial interface.

The sensing element, capable of detecting the acceleration, is manufactured using a dedicated process developed by ST to produce inertial sensors and actuators in silicon.

The IC interface instead is manufactured using a CMOS process that allows high level of integration to design a dedicated circuit which is factory trimmed to better match the sensing element characteristics.

The LIS302DL has a user selectable full scale of $\pm 2g$, $\pm 8g$ and it is capable of measuring accelerations with an output data rate of 100Hz or 400Hz. A self-test capability allows the user to check the correct operation of the system.

The device features two independent highly programmable interrupt sources that can be configured either to generate an inertial wake-up interrupt signal when a programmable acceleration threshold is exceeded along one of the three axes or to detect a free-fall event. Two independent pins can be configured to provide interrupt signals to connected devices.

The LIS302DL is available in plastic SMD package and it is specified over a temperature range extending from -40°C to $+85^{\circ}\text{C}$.

The ultra small size and weight of this package make it an ideal choice for handheld portable applications such as cell phones and PDAs or any other application where reduced package size and weight are required.

Contents

- 1 Theory of operation 6**
- 2 Electrical connection and board layout hints 7**
 - 2.1 Electrical connection 7
 - 2.2 Soldering information 8
- 3 Absolute maximum ratings 8**
- 4 Digital interfaces 9**
 - 4.1 I2C Bus interface 9
 - 4.1.1 I2C Operation 10
 - 4.1.2 I2C Subsequences 11
 - 4.2 SPI bus interface 13
 - 4.2.1 Read & write protocol 13
 - 4.2.2 SPI read 14
 - 4.2.3 SPI Write 14
 - 4.2.4 SPI Read in 3-wires mode 15
- 5 Registers description 16**
 - 5.1 Registers address map 16
 - 5.1.1 Reserved Registers 17
 - 5.1.2 Registers loaded at Boot 17
- 6 About control registers 18**
 - 6.1 CTRL_REG1 (20h) 18
 - 6.2 CTRL_REG2 (21h) 19
 - 6.3 CTRL_REG3 (22h) 20
- 7 Data and status registers 22**
 - 7.1 WHO_AM_I (0Fh) 22
 - 7.2 STATUS_REG (27h) 22
 - 7.3 OUTX (29h) 23
 - 7.4 OUTY (2Bh) 23

7.5	OUTZ (2Dh)	23
8	Free-Fall and Wake-Up Registers	24
8.1	HP_FILTER_RESET (23h)	24
8.2	FF_WU_CFG_1 (30h)	24
8.3	FF_WU_SRC_1 (31h)	25
8.4	FF_WU_THS_1 (32h)	26
8.5	FF_WU_DURATION_1 (33h)	27
8.6	FF_WU_CFG_2 (34h)	28
8.7	FF_WU_SRC_2 (35h)	29
8.8	FF_WU_THS_2 (36h)	29
8.9	FF_WU_DURATION_2 (37h)	30
9	Application Information	31
9.1	START-UP SEQUENCE	31
9.2	READING ACCELERATION DATA	31
9.2.1	Using the Status Register	31
9.2.2	Using the Data-Ready Signal	31
9.3	Understanding acceleration data	32
9.4	Interrupt generation description	33
9.5	INERTIAL WAKE-UP	34
9.5.1	HP Filter Bypassed	34
9.5.2	Using the HP Filter	35
9.6	Free-Fall Detection	36
9.6.1	Roll function not used	36
9.6.2	Roll function applied	36
9.7	Output data rate selection and reading timing	37
9.8	Data ready vs. interrupt signal	38
10	Revision history	39

List of tables

Table 1.	Absolute maximum ratings	8
Table 2.	Serial interface pin description	9
Table 3.	Terminology	9
Table 4.	Registers address map	16
Table 5.	Output Data Registers content vs. Acceleration	32
Table 6.	Output Data Rate	37
Table 7.	Timing Value to Avoid Loosing the Data.	37
Table 8.	Document revision history	39

List of figures

Figure 1.	Device block diagram	6
Figure 2.	LIS302DL electrical connection	7
Figure 3.	I2C Subsequences	12
Figure 4.	Read & write protocol	13
Figure 5.	SPI read protocol	14
Figure 6.	Multiple bytes SPI read protocol (2 bytes example)	14
Figure 7.	SPI Write Protocol	14
Figure 8.	Multiple Bytes SPI Write Protocol (2 bytes example)	15
Figure 9.	SPI Read Protocol In 3-wires Mode	15
Figure 10.	Digital Processing Chain Block Diagram	20
Figure 11.	FF_WU_CFG_1,2 High and Low value	25
Figure 12.	DCRM bit function.	27
Figure 13.	Interrupt Generation Block Diagram	33
Figure 14.	Free-Fall, Wake-Up Interrupt Generator	33
Figure 15.	Reading Timing.	37
Figure 16.	Interrupt and dataready signal generation block diagram.	38
Figure 17.	Data Ready Signal	38

1 Theory of operation

The LIS302DL is an ultracompact, low-power, digital output 3-axis linear accelerometer packaged in a LGA package. The complete device includes a sensing element and an IC interface able to take the information from the sensing element and to provide a signal to the external world through an I²C/SPI serial interface (*Figure 1*).

A proprietary process is used to create a surface micro-machined accelerometer. The technology allows to carry out suspended silicon structures which are attached to the substrate in a few points called anchors and are free to move in the direction of the sensed acceleration. To be compatible with the traditional packaging techniques a cap is placed on top of the sensing element to avoid blocking the moving parts during the moulding phase of the plastic encapsulation.

When an acceleration is applied to the sensor the proof mass displaces from its nominal position, causing an imbalance in the capacitive half-bridge. This imbalance is measured using charge integration in response to a voltage pulse applied to the sense capacitor.

At steady state the nominal value of the capacitors are few pico Farad and when an acceleration is applied the maximum variation of the capacitive load is of few femto Farad.

The complete measurement chain is composed by a low-noise capacitive amplifier which converts into an analog voltage the capacitive unbalancing of the MEMS sensor and by analog-to-digital converters.

The acceleration data may be accessed through an I²C/SPI interface thus making the device particularly suitable for direct interfacing with a microcontroller.

Data synchronization in digital system employing the device is made simpler through the usage of the Data-Ready signal (RDY) which indicates when a new set of measured acceleration data is available thus simplifying data synchronization in digital system employing the device itself.

The LIS302DL features also two independent fully programmable interrupt sources which can be programmed to generate an interrupt signal when a programmable acceleration threshold is exceeded along one of the three axes or to detect a free-fall event.

The IC interface is factory calibrated for sensitivity (So) and Zero-g level (Off).

The trimming values are stored inside the device by a non volatile structure. Any time the device is turned on, the trimming parameters are downloaded into the registers to be employed during the normal operation. This allows the user to employ the device without further calibration.

Figure 1. Device block diagram

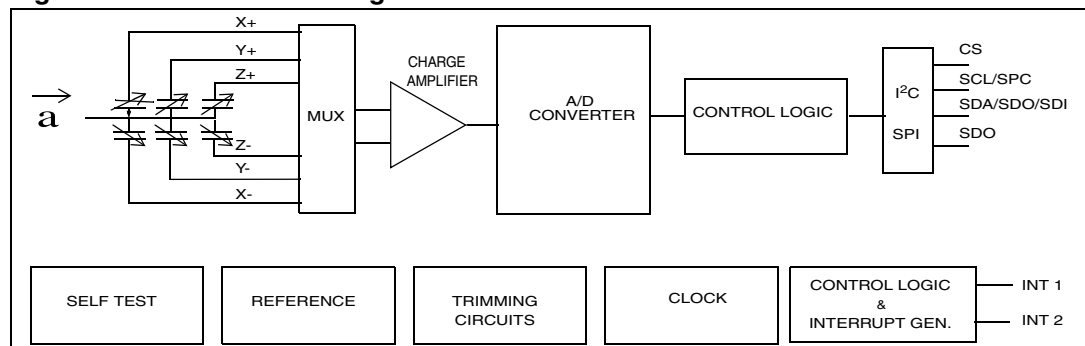

2 Electrical connection and board layout hints

2.1 Electrical connection

The typical electrical connection of the LIS302DL is shown in [Figure 2](#)

Figure 2. LIS302DL electrical connection

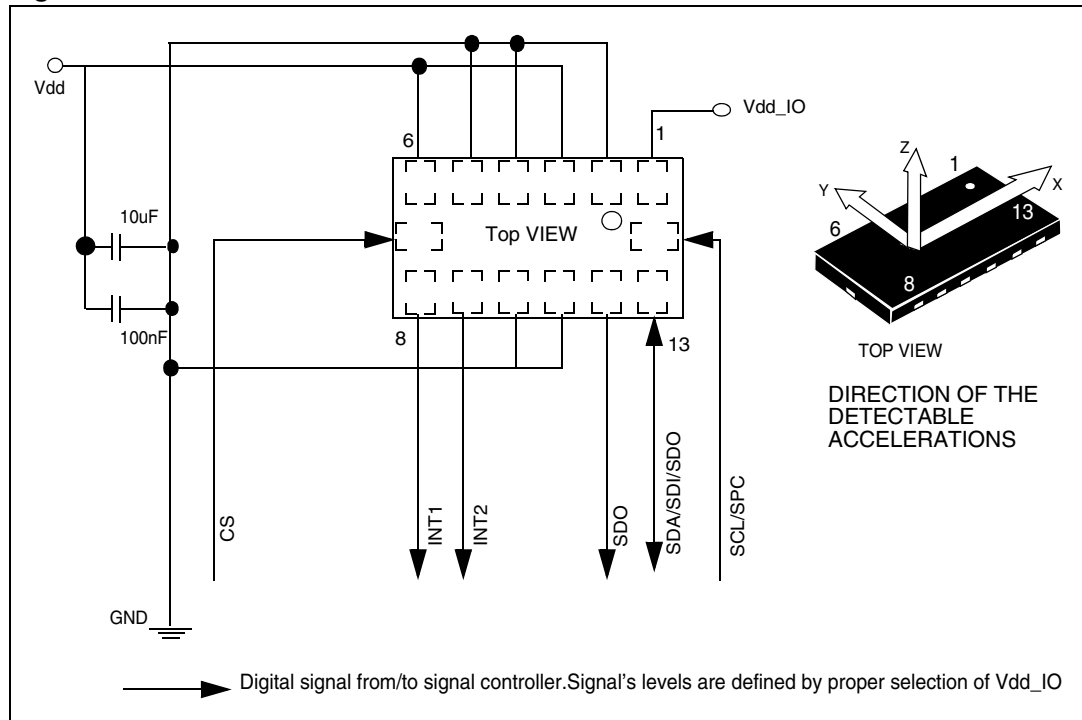

The LIS302DL is designed to operate with a voltage supply spanning from 2.16V up to 3.6V while the serial interface can work down to 1.8V.

The device core is supplied through Vdd line (Vdd typ=2.5V) while the I/O pads are supplied through Vdd_IO line. The typical current consumption in normal mode at 2.5V is 400µA.

Both the voltage supplies must be present at the same time to have proper behavior of the IC. It is possible to remove Vdd maintaining Vdd_IO without blocking the communication bus.

Adequate power supply decoupling is required to ensure IC performances. The optimum decoupling is achieved by using two capacitors of different types that target different kinds of noise on the power supply leads. To attenuate high frequency transients, spikes, or digital hash on the line it is recommended the use of one 100nF ceramic or polyester capacitor which must be placed as close as possible to device Vdd lead. For filtering lower-frequency noise signals, a larger aluminum capacitor of 10µF or greater should be placed near the device in parallel to the former capacitor. It is recommended to place these capacitors as near as possible to the pin 6 of the device.

The functionality of the device and the measured acceleration data are selectable and accessible through the I²C/SPI interface. When using the I²C, CS must be tied high while SDO allows to select among two device addresses in case two sensors must be connected on the same bus. Whenever one single sensor is present on the same I²C bus it is recommended either to connect SDO to Vdd_IO or to leave it floating.

2.2 Soldering information

The LGA-14 package is lead free and green package qualified for soldering heat resistance according to JEDEC J-STD-020C. Land pattern and soldering recommendations are available upon request.

3 Absolute maximum ratings

Stresses above those listed as “absolute maximum ratings” may cause permanent damage to the device. This is a stress rating only and functional operation of the device under these conditions is not implied. Exposure to maximum rating conditions for extended periods may affect device reliability.

Table 1. Absolute maximum ratings

Symbol	Ratings	Maximum Value	Unit
Vdd	Supply voltage ⁽¹⁾	-0.3 to 6	V
Vdd_IO	I/O pins Supply voltage ⁽¹⁾	-0.3 to 6	V
Vin	Input voltage on any control pin (CS, SCL/SPC, SDA/SDI/SDO, CK)	-0.3 to Vdd_IO +0.3	V
A _{POW}	Acceleration (Any axis, Powered, Vdd=2.5V)	3000g for 0.5 ms	
		10000g for 0.1 ms	
A _{UNP}	Acceleration (Any axis, Unpowered)	3000g for 0.5 ms	
		10000g for 0.1 ms	
T _{OP}	Operating Temperature Range	-40 to +85	°C
T _{STG}	Storage Temperature Range	-40 to +125	°C
ESD	Electrostatic discharge protection	Class 1: 0 - 2KV HBM	

1. Supply voltage on any pin should never exceed 6.0V



Warning: This is a ESD sensitive device, improper handling can cause permanent damages to the part.



Warning: This is a mechanical shock sensitive device, improper handling can cause permanent damages to the part.

4 Digital interfaces

The registers embedded inside the LIS302DL may be accessed through I²C and SPI serial interfaces. The latter may be SW configured to operate either in 3-wire or 4-wire interface mode.

The serial interfaces are mapped onto the same pads. To select/exploit the I²C interface, **CS** line must be tied high (i.e connected to Vdd_IO).

Table 2. Serial interface pin description

Pin Name	Pin Description
CS	SPI chip select (CS) I ² C/SPI selector (1: I ² C mode; 0: SPI enabled)
SCL/SPC	SPI CK line (SCL) I ² C clock line (SPC)
SDI/SDA/SDO	I ² C serial data (SDA) SPI data in (SDI) SPI data out (SDO) -for 3-wire SPI mode-
SDO	I ² C less significant bit of device address SPI data out (SDO) -for 4-wire SPI mode-

4.1 I²C Bus interface

The LIS302DL I²C is a bus slave. The I²C is employed to write/read the data into/from the registers.

The relevant I²C terminology is shown in [Table 3](#):

Table 3. Terminology

Term	Description
Transmitter	The device which sends data to the bus
Receiver	The device which receives data from the bus
Master	The device which initiates a transfer, generates clock signals and terminates a transfer
Slave	The device addressed by the master

There are two signals associated with the I²C bus: the Serial Clock Line (SCL) and the Serial DATA line (SDA). The latter is a bidirectional line used for sending and receiving the data to/from the interface. Both the lines are connected to Vdd_IO through a pull-up resistor embedded inside the LIS302DL. When the bus is free both the lines are high.

The I²C interface is compliant with Fast Mode (400 kHz) I²C standards as well as the Normal Mode.

4.1.1 I²C Operation

The transaction on the bus is started through a START (ST) condition which is defined as a HIGH to LOW transition on the data line while the SCL line is held HIGH. After the START condition has been generated by the Master, the bus is considered busy. The next byte of data transmitted contains the address of the slave in the first 7 bits and the eighth bit tells whether the Master is receiving data from the slave or transmitting data to the slave (SAD subsequence). When an address is sent, each device in the system compares the first seven bits after a start condition with its own address. If they match, the device considers itself addressed by the Master.

The Slave Address (SAD) associated to the LIS302DL may be selected among the two predefined values 0011100b or 0011101b depending on the logic level present on SDO pin. In details, if SDO pin is either connected to Vdd_IO or left unconnected the slave address is 0011101b, otherwise when it is connected to GND the slave address is 0011100b. Whenever it is not needed to place two sensors on the same bus it is recommended to use the slave address 0011101b by either connecting the SDO pin to Vdd_IO or leaving it floating.

Data transfer with acknowledge is mandatory. The transmitter must release the **SDA** line during the acknowledge pulse. The receiver must then pull the data line LOW so that it remains stable low during the HIGH period of the acknowledge clock pulse. A receiver which has been addressed is obliged to generate an acknowledge after each byte of data has been received.

The I²C embedded inside the LIS302DL behaves like a slave device and the following protocol must be adhered to. After the start condition (ST) a slave address is sent, once a slave acknowledge (SAK) has been returned, a 8-bit sub-address will be transmitted: the 7 LSb represent the actual register address while the MSB enables address auto increment. If the MSb of the SUB field is 1, the SUB (register address) will be automatically incremented to allow multiple data read/write. Otherwise if the MSB of the SUB field is '0', the SUB will remain unchanged and multiple read/write on the same address can be performed.

The slave address is completed with a Read/Write bit. If the bit was '1' (Read), a repeated START (SR) condition will have to be issued after the two sub-address bytes; if the bit is '0' (Write) the Master will transmit to the slave with direction unchanged.

Transfer when Master is writing one byte to slave

Master	ST	SAD + W		SUB		DATA		SP
Slave			SAK		SAK		SAK	

Transfer when Master is writing multiple bytes to slave:

Master	ST	SAD + W		SUB		DATA		DATA		SP
Slave			SAK		SAK		SAK		SAK	

Transfer when Master is receiving (reading) one byte of data from slave:

Master	ST	SAD + W		SUB		SR	SAD + R			NMAK	SP
Slave			SAK		SAK			SAK	DATA		

Transfer when Master is receiving (reading) multiple bytes of data from slave

Master	ST	SAD + W		SUB		SR	SAD + R			MAK
Slave			SAK		SAK			SAK	DATA	

Master		MAK		NMAK	SP
Slave	DATA		DATA		

Data are transmitted in byte format (DATA). Each data transfer contains 8 bits. The number of bytes transferred per transfer is unlimited. Data is transferred with the Most Significant bit (MSb) first. If a receiver can't receive another complete byte of data until it has performed some other function, it can hold the clock line, **SCL LOW** to force the transmitter into a wait state. Data transfer only continues when the receiver is ready for another byte and releases the data line. If a slave receiver doesn't acknowledge the slave address (i.e. it is not able to receive because it is performing some real time function) the data line must be left HIGH by the slave. The Master can then abort the transfer. A LOW to HIGH transition on the **SDA** line while the **SCL** line is HIGH is defined as a STOP condition. Each data transfer must be terminated by the generation of a STOP (SP) condition.

In order to read multiple bytes, it is necessary to assert the most significant bit of the sub-address field. In other words, SUB(7) must be equal to 1 while SUB(6-0) represents the address of first register to read.

In the presented communication format MAK is Master Acknowledge and NMAK is No Master Acknowledge.

4.1.2 I²C Subsequences

In order to better define subsequences and to clarify line **SCL** and **SDA** behavior, a description containing discrete value of **SCL** and **SDA** will follow. In column there is the value present on line **SCL** and **SDA** in discrete timing. These simple subsequences are used to realize complex commands described in the following paragraph.

Figure 3. I²C Subsequences

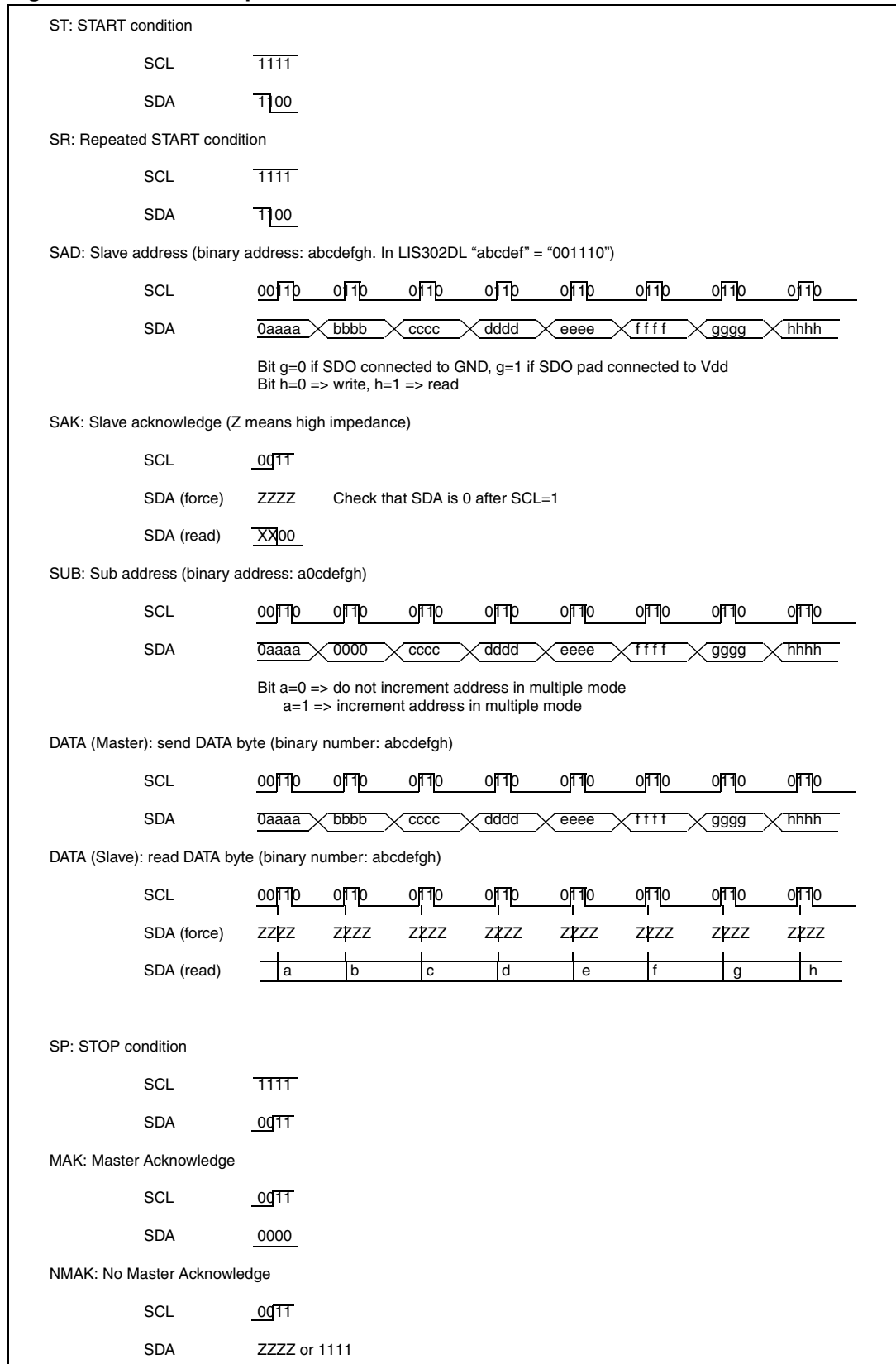

4.2 SPI bus interface

The LIS302DL SPI is a bus slave. The SPI allows to write and read the registers of the device.

The Serial Interface interacts with the outside world with 4 wires: **CS**, **SPC**, **SPDI** and **SPDO**.

4.2.1 Read & write protocol

Figure 4. Read & write protocol

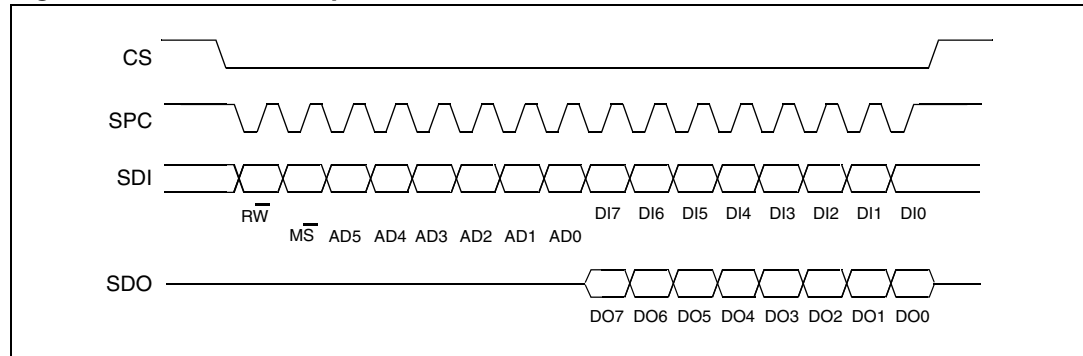

CS is the Chip Select and it is controlled by the SPI master. It goes low at the start of the transmission and goes back high at the end. **SPC** is the Serial Port Clock and it is controlled by the SPI master. It is stopped high when **CS** is high (no transmission). **SDI** and **SDO** are respectively the Serial Port Data Input and Output. Those lines are driven at the falling edge of **SPC** and should be captured at the rising edge of **SPC**.

Both the Read Register and Write Register commands are completed in 16 clocks pulses or in multiple of 8 in case of multiple byte read/write. Bit duration is the time between two falling edges of **SPC**. The first bit (bit 0) starts at the first falling edge of SPC after the falling edge of **CS** while the last bit (bit 15, bit 23, ...) starts at the last falling edge of SPC just before the rising edge of **CS**.

bit 0: \overline{RW} bit. When 0, the data DI(7:0) is written into the device. When 1, the data DO(7:0) from the device is read. In latter case, the chip will drive **SDO** at the start of bit 8.

bit 1: \overline{MS} bit. When 0, the address will remain unchanged in multiple read/write commands. When 1, the address will be auto incremented in multiple read/write commands.

bit 2-7: address AD(5:0). This is the address field of the indexed register.

bit 8-15: data DI(7:0) (write mode). This is the data that will be written into the device (MSb first).

bit 8-15: data DO(7:0) (read mode). This is the data that will be read from the device (MSb first).

In multiple read/write commands further blocks of 8 clock periods will be added. When MS bit is 0 the address used to read/write data remains the same for every block. When MS bit is 1 the address used to read/write data is incremented at every block.

The function and the behavior of **SDI** and **SDO** remain unchanged.

4.2.2 SPI read

Figure 5. SPI read protocol

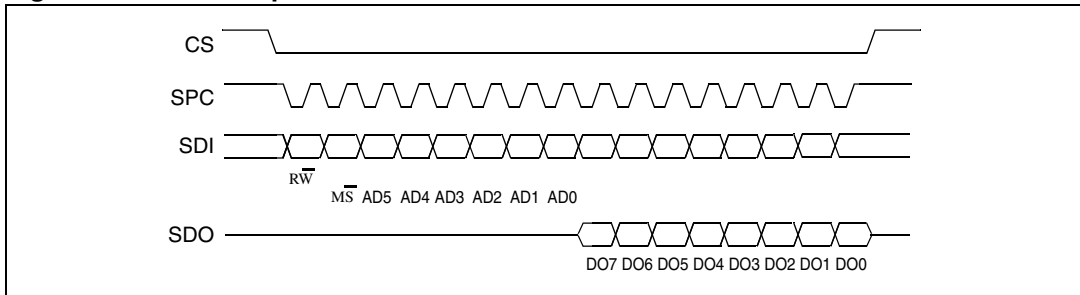

The SPI Read command is performed with 16 clocks pulses. Multiple byte read command is performed adding blocks of 8 clocks pulses at the previous one.

bit 0: READ bit. The value is 1.

bit 1: \overline{MS} bit. When 0 do not increment address, when 1 increment address in multiple reading.

bit 2-7: address AD(5:0). This is the address field of the indexed register.

bit 8-15: data DO(7:0) (read mode). This is the data that will be read from the device (\overline{MS} first).

bit 16-... : data DO(...-8). Further data in multiple byte reading.

Figure 6. Multiple bytes SPI read protocol (2 bytes example)

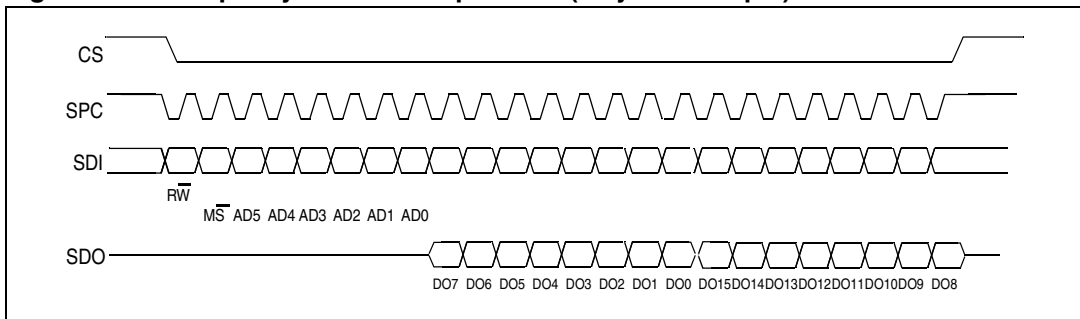

4.2.3 SPI Write

Figure 7. SPI Write Protocol

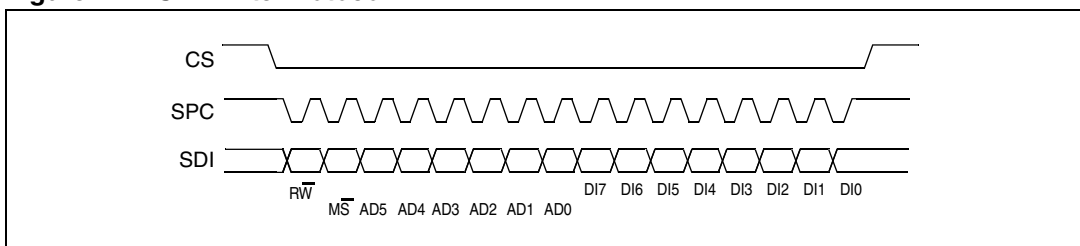

The SPI Write command is performed with 16 clocks pulses. Multiple byte write command is performed adding blocks of 8 clocks pulses at the previous one.

bit 0: WRITE bit. The value is 0.

bit 1: MS bit. When 0 do not increment address, when 1 increment address in multiple writing.

bit 2 -7: address AD(5:0). This is the address field of the indexed register.

bit 8-15: data DI(7:0) (write mode). This is the data that will be written inside the device (MSb first).

bit 16-... : data DI(...-8). Further data in multiple byte writing.

Figure 8. Multiple Bytes SPI Write Protocol (2 bytes example)

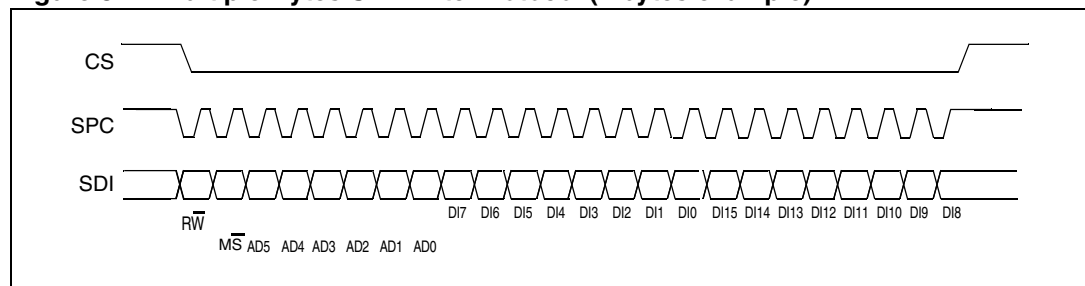

4.2.4 SPI Read in 3-wires mode

3-wires mode is entered by setting to 1 bit SIM (SPI Serial Interface Mode selection) in CTRL_REG2.

Figure 9. SPI Read Protocol In 3-wires Mode

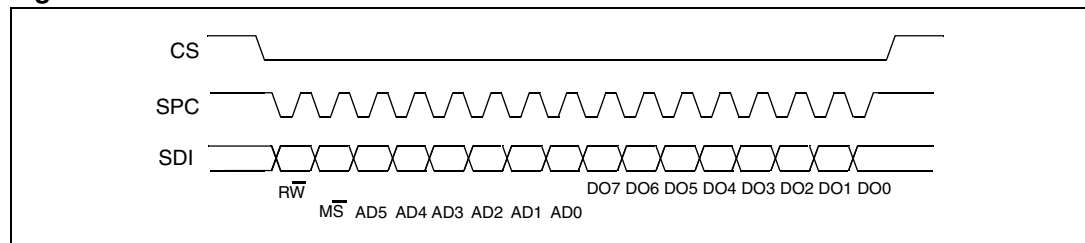

The SPI Read command is performed with 16 clocks pulses:

bit 0: READ bit. The value is 1.

bit 1: MS bit. When 0 do not increment address, when 1 increment address in multiple reading.

bit 2-7: address AD(5:0). This is the address field of the indexed register.

bit 8-15: data DO(7:0) (read mode). This is the data that will be read from the device (MSb first).

Multiple read command is also available in 3-wires mode.

5 Registers description

5.1 Registers address map

The table given below provides a listing of the registers embedded in the device.

Table 4. Registers address map

Name	Type	Register Address		Default	Comment
		Hex	Binary		
Reserved (Do not modify)		00-0E			Reserved
Who_Am_I	r	0F	00 1111	00111011	Dummy register
Reserved (Do not modify)		10-1F			Reserved
Ctrl_Reg1	rw	20	10 0000	00000111	
Ctrl_Reg2	rw	21	10 0001	00000000	
Ctrl_Reg3	rw	22	10 0010	00000000	
HP_filter_reset	r	23	10 0011	dummy	Dummy register
Reserved (Do not modify)		24-26			Reserved
Status_Reg	r	27	10 0111	00000000	
--	r	28	10 1000		Not Used
Out_X	r	29	10 1001	output	
--	r	2A	10 1010		Not Used
Out_Y	r	2B	10 1011	output	
--	r	2C	10 1100		Not Used
Out_Z	r	2D	10 1101	output	
Reserved (Do not modify)		2E-2F			Reserved
FF_WU_CFG_1	rw	30	11 0000	00000000	
FF_WU_SRC_1(ack1)	r	31	11 0001	00000000	
FF_WU_THS_1	rw	32	11 0010	00000000	
FF_WU_DURATION_1	rw	33	11 0011	00000000	
FF_WU_CFG_2	rw	34	11 0100	00000000	
FF_WU_SRC_2 (ack2)	r	35	11 0101	00000000	
FF_WU_THS_2	rw	36	11 0110	00000000	
FF_WU_DURATION_2	rw	37	11 0111	00000000	
Reserved (Do not modify)		38-3F			Reserved

5.1.1 **Reserved Registers**

Registers marked as reserved must not be changed. Random changes of the content of those registers might cause permanent damages to the device.

5.1.2 **Registers loaded at Boot**

The LIS302DL is factory trimmed. The content of the registers that are loaded at boot must not be changed. Their content is automatically restored when the device is powered-up.

6 About control registers

6.1 CTRL_REG1 (20h)

Control register #1.

DR	PD	FS	STP	STM	Zen	Yen	Xen
DR	Data rate selection. Default value: 0 (0: 100 Hz output data rate; 1: 400 Hz output data rate)						
PD	Power Down Control. Default value: 0 (0: power down mode; 1: active mode)						
FS	Full Scale selection. Default value: 0 (0: +/- 2g; 1: +/- 8g)						
STP, STM	Self Test Enable. Default value: 00 (00: normal mode; 10: self test P; 01 self test M; 11: forbidden)						
Zen	Z axis enable. Default value: 1 (0: Z axis disabled; 1: Z axis enabled)						
Yen	Y axis enable. Default value: 1 (0: Y axis disabled; 1: Y axis enabled)						
Xen	X axis enable. Default value: 1 (0: X axis disabled; 1: X axis enabled)						

DR bit allows to select the data rate at which acceleration samples are produced. The default value is 0 which corresponds to a data-rate of 100Hz. By changing the content of DR to 1 the selected data-rate will be set equal to 400Hz.

PD bit allows to turn the device out of power-down mode. The device is in power-down mode when PD= "0" (default value after boot). The device is in normal mode when PD is set to 1.

DR (DataRate)	PD (PowerDown)	Status
0	0	Power Down (Default)
0	1	Active (100Hz output)
1	0	Power Down
1	1	Active (400Hz output)

STP, STM bits are used to activate the self test function. When one of the bit is set to 1, an output change will occur to the device outputs (refer to datasheet for specification) thus allowing to check the functionality of the whole measurement chain. STP and STM move the output in opposite directions.

Zen bit enables the generation of DataReady signal for Z-axis measurement channel when set to 1. The default value is 1.

Yen bit enables the generation of DataReady signal for Y-axis measurement channel when set to 1. The default value is 1.

Xen bit enables the generation of DataReady signal for X-axis measurement channel when set to 1. The default value is 1.

6.2 CTRL_REG2 (21h)

Control register #2.

SIM	BOOT	--	FDS	HP FF_WU2	HP FF_WU1	HP coeff2	HP coeff1
SIM	SPI Serial Interface Mode selection. Default value: 0 (0: 4-wire interface; 1: 3-wire interface)						
BOOT	Reboot memory content. Default value: 0 (0: normal mode; 1: reboot memory content)						
FDS	Filtered Data Selection. Default value: 0 (0: internal filter bypassed; 1: data from internal filter sent to output register)						
HP FF_WU2	High Pass filter enabled for FreeFall/WakeUp # 2. Default value: 0 (0: filter bypassed; 1: filter enabled)						
HP FF_WU1	High Pass filter enabled for Free-Fall/Wake-Up #1. Default value: 0 (0: filter bypassed; 1: filter enabled)						
HP coeff2 HP coeff1	High pass filter cut-off frequency configuration. Default value: 00						

SIM bit selects the SPI Serial Interface Mode. When SIM is '0' (default value) the 4-wire interface mode is selected. The data coming from the device are sent to SDO pad. In 3-wire interface mode output data are sent to SDA/SDI pad.

BOOT bit is used to refresh the content of internal registers stored in the flash memory block. At the device power up the content of the flash memory block is transferred to the internal registers related to trimming functions to permit a good behavior of the device itself. If for any reason the content of trimming registers was changed it is sufficient to use this bit to restore correct values. When BOOT bit is set to '1' the content of internal flash is copied inside corresponding internal registers and it is used to calibrate the device. These values are factory trimmed, they are different for every accelerometer and normally they have not to be changed. At the end of the boot process the BOOT bit is set again to '0'.

FDS bit enables (FDS=1) or bypass (FDS=0) the high pass filter in the signal chain of the sensor.

HP FF_WU[2:1]. These bits enable (HP FF_WU=1) or bypass (HP FF_WU=0) the high pass filter in interrupt generation blocks.

HP coeff[2:1]. These bits are used to configure high-pass filter cut-off frequency ft accordingly to the table given below:

HPcoeff2,1	ft (Hz) (DR=100 Hz)	ft (Hz) (DR=400 Hz)
00	2	8
01	1	4
10	0.5	2
11	0.25	1

Figure 10 shows the block diagram of the digital processing chain and the related control signals.

Figure 10. Digital Processing Chain Block Diagram

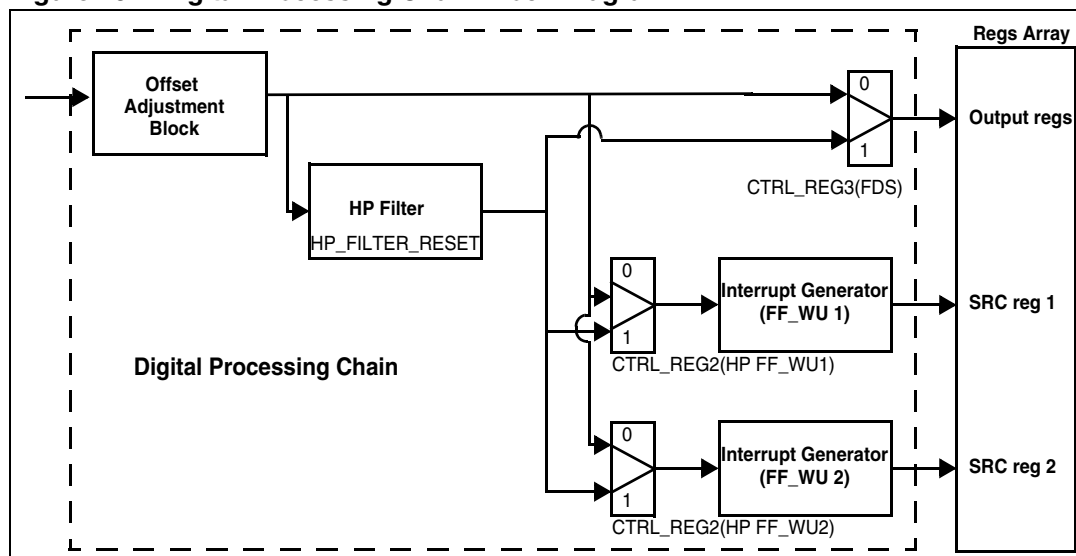

6.3 CTRL_REG3 (22h)

Control register #3.

IHL	PP_OD	I2CFG2	I2CFG1	I2CFG0	I1CFG2	I1CFG1	I1CFG0
-----	-------	--------	--------	--------	--------	--------	--------

IHL	Interrupt active high, low. Default value 0. (0: active high; 1: active low)
PP_OD	Push-pull/Open Drain selection on interrupt pad. Default value 0. (0: push-pull; 1: open drain)
I2CFG2, I2CFG0	Interrupt 2 configuration bits. Default value 000. (see table below)
I1CFG2, I1CFG0	Interrupt 1 configuration bits. Default value 000. (see table below)

IHL bit selects the polarity of the interrupt signal. When IHL is '0' (default value) any interrupt event will signalled with a logical 1.

PP_OD bit defines whether the interrupt pad has to work in Push-pull or in Open Drain mode. The latter is specifically intended for wired-or connection of multiple interrupt signals on the same interrupt line. The default value is '0' which corresponds to push-pull mode.

I2CFG[2:0] and **I1CFG[2:0]** bit select which signal has to be sent out from the INT2 and INT1 interrupt pads as described in the following table:

I2CFG2	I2CFG1	I2CFG0	INT2 Pin
I1CFG2	I1CFG1	I1CFG0	INT1 Pin
0	0	0	GND
0	0	1	FF_WU 1
0	1	0	FF_WU 2
0	1	1	FF_WU1 or FF_WU2
1	0	0	Datready
1	1	1	--

Two completely independent interrupt blocks are available in LIS302DL: FF_WU1 and FF_WU2. They can be configured using registers described in Section 8.

HP filtered data can be selected for further processing by the Interrupt Generator block setting the desired values of HP FF_WU1 and HP FF_WU2 bits in CTRL_REG2. Default value is '0' and corresponds to the use of non filtered data. The output of Interrupt Generator block is used to load FF_WU_SRC_1 and FF_WU_SRC_2 registers.

7 Data and status registers

7.1 WHO_AM_I (0Fh)

Device identification register.

0	0	1	1	1	0	1	1
---	---	---	---	---	---	---	---

This register contains a device identifier which for LIS302DL is set to 3Bh.

7.2 STATUS_REG (27h)

Data output status register.

ZYXOR	ZOR	YOR	XOR	ZYXDA	ZDA	YDA	XDA
-------	-----	-----	-----	-------	-----	-----	-----

ZYXOR	X, Y and Z axes Data Overrun. Default value: 0 (0: no overrun has occurred; 1: new data has overwritten the previous one before it was read)
ZOR	Z axis Data Overrun. Default value: 0 (0: no overrun has occurred; 1: a new data for the Z-axis has overwritten the previous one)
YOR	Y axis Data Overrun. Default value: 0 (0: no overrun has occurred; 1: a new data for the Y-axis has overwritten the previous one)
XOR	X axis Data Overrun. Default value: 0 (0: no overrun has occurred; 1: a new data for the X-axis has overwritten the previous one)
ZYXDA	X, Y and Z axis new Data Available. Default value: 0 (0: a new set of data is not yet available; 1: a new set of data is available)
ZDA	Z axis new Data Available. Default value: 0 (0: a new data for the Z-axis is not yet available; 1: a new data for the Z-axis is available)
YDA	Y axis new Data Available. Default value: 0 (0: a new data for the Y-axis is not yet available; 1: a new data for the Y-axis is available)
XDA	X axis new Data Available. Default value: 0 (0: a new data for the X-axis is not yet available; 1: a new data for the X-axis is available)

ZYXOR is set to one whenever a new acceleration data is produced before completing the retrieval of the previous set. When this occurs, the content of at least one acceleration data register (i.e. OUTX, OUTY, OUTZ) has been overwritten. ZYXOR is cleared when the acceleration data (OUTX, OUTY, OUTZ) of all the active channels are read.

ZOR is set to 1 whenever a new acceleration sample related to the Z-axis is generated before the retrieval of the previous sample. When this occurs the previous sample is overwritten. ZOR is cleared anytime OUTZ register is read.

YOR is set to 1 whenever a new acceleration sample related to the Y-axis is generated before the retrieval of the previous sample. When this occurs the previous sample is overwritten. YOR is cleared anytime OUTY_H register is read.

XOR is set to 1 whenever a new acceleration sample related to the X-axis is generated before the retrieval of the previous sample. When this occurs the previous sample is overwritten. XOR is cleared anytime OUTX_H register is read.

The **ZYXDA** bit signals that a new sample for all the enabled channels is available. ZYXDA is cleared when the acceleration data (OUTX, OUTY, OUTZ) of all the enabled channels are read.

ZDA is set to 1 whenever a new acceleration sample related to the Z-axis is available. ZDA is cleared anytime OUTZ register is read. In order to trigger, the ZDA bit requires the Z axis to be enabled (bit Zen=1 inside CTRL_REG1).

YDA is set to 1 whenever a new acceleration sample related to the Y-axis is available. YDA is cleared anytime OUTY register is read. In order to trigger, the YDA bit requires the Y axis to be enabled (bit Yen=1 inside CTRL_REG1).

XDA is set to 1 whenever a new acceleration sample related to the X-axis is available. XDA is cleared anytime OUTX register is read. In order to trigger, the XDA bit requires the X axis to be enabled (bit Xen=1 inside CTRL_REG1).

7.3 OUTX (29h)

X-axis output register.

XD7	XD6	XD5	XD4	XD3	XD2	XD1	XD0
-----	-----	-----	-----	-----	-----	-----	-----

7.4 OUTY (2Bh)

Y-axis output register.

YD7	YD6	YD5	YD4	YD3	YD2	YD1	YD0
-----	-----	-----	-----	-----	-----	-----	-----

7.5 OUTZ (2Dh)

Z-axis output register.

ZD7	ZD6	ZD5	ZD4	ZD3	ZD2	ZD1	ZD0
-----	-----	-----	-----	-----	-----	-----	-----

8 Free-Fall and Wake-Up Registers

The following sections describes the registers that are involved in the generation of the interrupt signal associated to the inertial wake-up and free-fall events.

8.1 HP_FILTER_RESET (23h)

Dummy register. A reading at this address forces the high-pass filter to recover instantaneously the dc level of the acceleration signal provided to its inputs. After the above reading the output of the high-pass filter will be zero.

X	X	X	X	X	X	X	X
---	---	---	---	---	---	---	---

8.2 FF_WU_CFG_1 (30h)

Free-fall and wake-up configuration register for interrupt source 1.

AOI	LIR	ZHIE	ZLIE	YHIE	YLIE	XHIE	XLIE
-----	-----	------	------	------	------	------	------

AOI	And/Or combination of Interrupt events. Default value: 0 (0: OR combination of interrupt events; 1: AND combination of interrupt events)
LIR	Latch Interrupt request into FF_WU_SRC reg with the FF_WU_SRC reg cleared by reading FF_WU_SRC_1 reg. Default value: 0 (0: interrupt request not latched; 1: interrupt request latched)
ZHIE	Enable interrupt generation on Z high event. Default value: 0 (0: disable interrupt request; 1: enable interrupt request on measured accel. value higher than preset threshold)
ZLIE	Enable interrupt generation on Z low event. Default value: 0 (0: disable interrupt request; 1: enable interrupt request on measured accel. value lower than preset threshold)
YHIE	Enable interrupt generation on Y high event. Default value: 0 (0: disable interrupt request; 1: enable interrupt request on measured accel. value higher than preset threshold)
YLIE	Enable interrupt generation on Y low event. Default value: 0 (0: disable interrupt request; 1: enable interrupt request on measured accel. value lower than preset threshold)
XHIE	Enable interrupt generation on X high event. Default value: 0 (0: disable interrupt request; 1: enable interrupt request on measured accel. value higher than preset threshold)
XLIE	Enable interrupt generation on X low event. Default value: 0 (0: disable interrupt request; 1: enable interrupt request on measured accel. value lower than preset threshold)

AOI bit allows to select between Wake-Up (OR combination of interrupt events) and Free-Fall (AND combination of interrupt events) detection

LIR defines whether the configured interrupt event has to be latched by the device once it has happened. The interrupt request is cleared by reading the related source reg (FF_WU_SRC_1).

XHIE (YHIE, ZHIE) set an interrupt event to occur when the measured acceleration data on X (Y, Z) channel is higher than the threshold set in FF_WU_THS_1 register.

XLIE (YLIE, ZLIE) set an interrupt event to occur when the measured acceleration data on X (Y, Z) channel is lower than the threshold set in FF_WU_THS_1 register.

The threshold module which is used by the system to detect any free-fall or inertial wake-up event is defined by FF_WU_THS_1. The threshold value is expressed over 7 bit as an unsigned number and X, (Y, Z) high is true when the unsigned acceleration value of the X (Y, Z) channel is higher than or equal to FF_WU_THS_1. Similarly, X, (Y, Z) low is true when the unsigned acceleration value of the X (Y, Z) channel is lower than FF_WU_THS_1. Refer to [Figure 11](#) for more details.

Figure 11. FF_WU_CFG_1,2 High and Low value

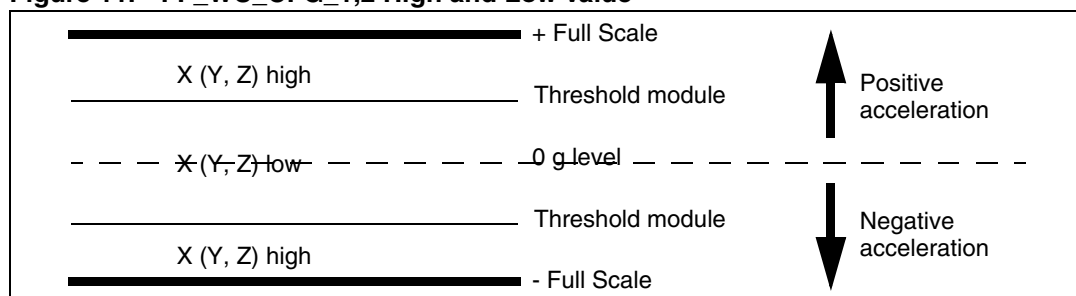

8.3 FF_WU_SRC_1 (31h)

Free-fall and wake-up source register for interrupt 1. Read only register.

x	IA	ZH	ZL	YH	YL	XH	XL
IA	Interrupt Active. Default value: 0 (0: no interrupt has been generated; 1: one or more interrupt event has been generated)						
ZH	Z High. Default value: 0 (0: no interrupt; 1: ZH event has occurred)						
ZL	Z Low. Default value: 0 (0: no interrupt; 1: ZL event has occurred)						
YH	Y High. Default value: 0 (0: no interrupt; 1: YH event has occurred)						
YL	Y Low. Default value: 0 (0: no interrupt; 1: YL event has occurred)						
XH	X High. Default value: 0 (0: no interrupt; 1: XH event has occurred)						
XL	X Low. Default value: 0 (0: no interrupt; 1: XL event has occurred)						

This register keeps track of the acceleration event which is being triggering (or has triggered, in case of LIR bit in FF_WU_SRC_1 reg set to 1) the interrupt signal. In particular IA is equal to 1 when the combination of acceleration events specified in FF_WU_CFG_1 register is true. This bit is used for the generation of the interrupt signal associated to the free-fall/wake-up events.

X, (Y, Z) high is true when the module of the acceleration value of the X (Y, Z) channel is higher than the preset threshold which is defined as the concatenation of FF_WU_THS_1.

Similarly, X, (Y, Z) low is true when the module of the acceleration value of the X (Y, Z) channel is lower than FF_WU_THS_1.

Reading at this address clears FF_WU_SRC_1 register and the FF_WU1 interrupt and allows the refreshment of data in the FF_WU_SRC_1 register itself if the latched option was chosen.

8.4 FF_WU_THS_1 (32h)

Free-fall, wake-up threshold for interrupt 1.

DCRM	THS6	THS5	THS4	THS3	THS2	THS1	THS0
DCRM	Duration counter reset mode selection. Default value: 0 (0: counter reset; 1: counter decremented)						
THS6, THS0	Free-fall / wake-up Threshold: default value: 000 0000						

DCRM bit allows to select the way in which the duration counter is reset. When DCRM is 0 the duration counter is reset immediately whenever the internal inertial event programmed by the user is not active (*Figure 12* part B) while it is decremented when DCRM is set to 1 (*Figure 12* part C). The latter configuration allows to filter out spurious spikes which might impair the recognition and validation of inertial events.

Figure 12. DCRM bit function

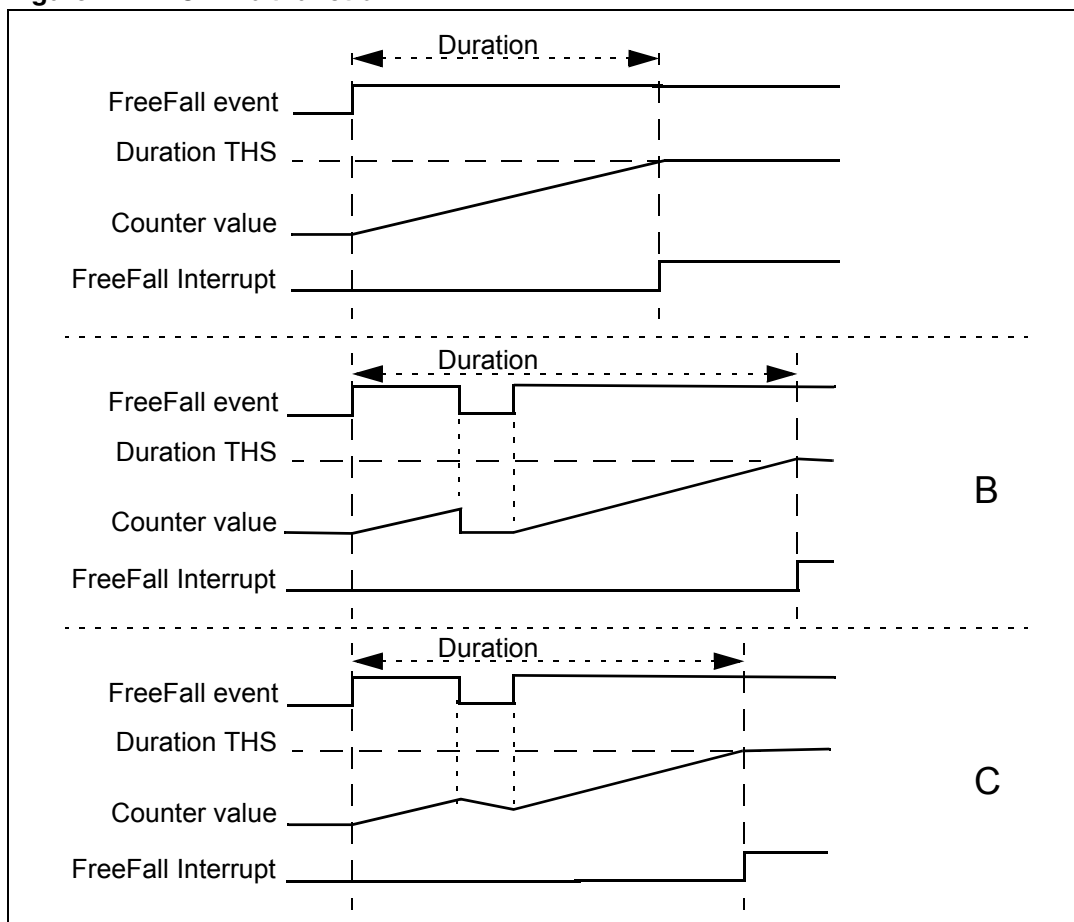

8.5 FF_WU_DURATION_1 (33h)

Set the minimum duration of the free-fall, wake-up event that must be recognized by the LIS302DL.

D7	D6	D5	D4	D3	D2	D1	D0
----	----	----	----	----	----	----	----

D7, D0	Duration value. Default value: 0000 0000
--------	--

D7, D0 define the minimum duration of the programmed inertial event such as Free-Fall and Wake-Up that must be recognized by the device. Duration step and maximum value depend on the ODR chosen. For an output data rate of 400 Hz the register allows to set a duration spanning from 0 to 637.5 msec with steps of 2.5 msec. Conversely when the output data rate is set to 100 Hz it is possible to define an event duration spanning from 0 to 2.55 sec at steps of 10 msec. The counter used to implement duration function is blocked when the LIR bit in the configuration register is set to one and the interrupt event has occurred.

8.6 FF_WU_CFG_2 (34h)

Free-fall and wake-up configuration register for interrupt source 2.

AOI	LIR	ZHIE	ZLIE	YHIE	YLIE	XHIE	XLIE
AOI	And/Or combination of Interrupt events. Default value: 0 (0: OR combination of interrupt events; 1: AND combination of interrupt events)						
LIR	Latch Interrupt request into FF_WU_SRC reg with the FF_WU_SRC reg cleared by reading FF_WU_SRC_1 reg. Default value: 0 (0: interrupt request not latched; 1: interrupt request latched)						
ZHIE	Enable interrupt generation on Z high event. Default value: 0 (0: disable interrupt request; 1: enable interrupt request on measured accel. value higher than preset threshold)						
ZLIE	Enable interrupt generation on Z low event. Default value: 0 (0: disable interrupt request; 1: enable interrupt request on measured accel. value lower than preset threshold)						
YHIE	Enable interrupt generation on Y high event. Default value: 0 (0: disable interrupt request; 1: enable interrupt request on measured accel. value higher than preset threshold)						
YLIE	Enable interrupt generation on Y low event. Default value: 0 (0: disable interrupt request; 1: enable interrupt request on measured accel. value lower than preset threshold)						
XHIE	Enable interrupt generation on X high event. Default value: 0 (0: disable interrupt request; 1: enable interrupt request on measured accel. value higher than preset threshold)						
XLIE	Enable interrupt generation on X low event. Default value: 0 (0: disable interrupt request; 1: enable interrupt request on measured accel. value lower than preset threshold)						

Two structures can be used to generate interrupts. They have exactly the same configuration capability and they are completely independent.
The interrupt result of each structure can be sent indifferently to INT1 or INT2 pin using CTRL_Reg3 register.

8.7 FF_WU_SRC_2 (35h)

Free-fall and wake-up source register for interrupt 2. Read only register. Refer to FF_WU_SRC_1 for details.

x	IA	ZH	ZL	YH	YL	XH	XL
IA	Interrupt Active. Default value: 0 (0: no interrupt has been generated; 1: one or more interrupt event has been generated)						
ZH	Z High. Default value: 0 (0: no interrupt; 1: ZH event has occurred)						
ZL	Z Low. Default value: 0 (0: no interrupt; 1: ZL event has occurred)						
YH	Y High. Default value: 0 (0: no interrupt; 1: YH event has occurred)						
YL	Y Low. Default value: 0 (0: no interrupt; 1: YL event has occurred)						
XH	X High. Default value: 0 (0: no interrupt; 1: XH event has occurred)						
XL	X Low. Default value: 0 (0: no interrupt; 1: XL event has occurred)						

Reading at this address clears FF_WU_SRC_2 register and the FF_WU2 interrupt and allows the refreshment of data in the FF_WU_SRC_2 register if the latched option was chosen.

8.8 FF_WU_THS_2 (36h)

Free-fall, wake-up threshold for interrupt source 2.

DCRM	THS6	THS5	THS4	THS3	THS2	THS1	THS0
DCRM	Duration counter reset mode selection. Default value: 0 (0: counter reset; 1: counter decremented)						
THS6, THS0	Free-fall / wake-up Threshold: default value: 000 0000						

DCRM bit and THS6 to THS0 behave exactly like bit in FF_WU_THS_1 but they are applied to interrupt source 2.

8.9 FF_WU_DURATION_2 (37h)

Set the minimum duration of the free-fall, wake-up event that must be recognized by the LIS302DL.

D7	D6	D5	D4	D3	D2	D1	D0
D7, D0		Duration value. Default value: 0000 0000					

Refer to FF_WU_DURATION_1 for details.

9 Application Information

9.1 START-UP SEQUENCE

Once the device is powered-up it automatically downloads the calibration coefficients from the embedded flash to the internal registers. When the boot procedure is completed, i.e. approximately after 3 milli-seconds, the device automatically enters power-down mode.

To turn-on the device and gather acceleration data it is necessary to write 47h inside the CTRL_REG1. With this command the three acceleration channels (i.e. X, Y and Z axis) are enabled and the Output Data Rate is set to 100 Hz.

9.2 READING ACCELERATION DATA

9.2.1 Using the Status Register

The device is provided with a STATUS_REG which should be polled to check when a new set of data is available. The reading procedure should be the following:

- 1 read STATUS_REG
- 2 if STATUS_REG(3)=0 then goto 1
- 3 if STATUS_REG(7)=1 then some data have been overwritten
- 4 read OUTX
- 5 read OUTY
- 6 read OUTZ
- 7 data processing
- 8 goto 1

The check performed at step 3 allows to understand whether the reading rate is adequate compared to the data production rate. In case one or more acceleration samples have been overwritten by new data because of a reading rate too slow, the bit STATUS_REG(7) will be set to 1.

The overrun bit are automatically cleared when all the data present inside the device have been read and new data have not been produced in the meanwhile.

9.2.2 Using the Data-Ready Signal

The device may be configured to generate one HW signal (Data Ready) on either pin 8 or 9 to flag that a new set of measurement data is available for reading. This signal corresponds to the ZYXDA bit present inside the STATUS_REG. The polarity of the signal is defined through the IHL bit present inside the CTRL_REG3 and it is deasserted when the acceleration data of all the enabled channels have been read. To enable Data Ready signal on pin #8 (corresponding to INT1) it is necessary to set I1CFG[2:0] bit present inside the CTRL_REG3 to 100. Conversely, to enable Data Ready signal on pin #9 (corresponding to INT2) it is necessary to set I2CFG[2:0] bit present inside the CTRL_REG3 to 100.

9.3 Understanding acceleration data

The measured acceleration data are sent into OUTX, OUTY and OUTZ registers. The acceleration values are expressed as a 2's complement number. When the full-scale is set to 2g, each LSB corresponds to 18mg.

The table below provides few basic examples of the data that will be read in the data registers when the device is subject to a given acceleration. The values listed in the table are given under the hypothesis of perfect device calibration (i.e no offset, no gain error,) and rounded to the closest integer.

Table 5. Output Data Registers content vs. Acceleration

Acceleration Values	FS bit = 0	FS bit = 1
	Output Register Content	
0g	00h	00h
350mg	14h	05h
1g	38h	0Eh
2g	6Fh	1Ch
-350mg	ECh	FBh
-1g	C8h	F2h
-2g	91h	E4h

9.4 Interrupt generation description

The LIS302DL provide two fully-programmable interrupt sources which may be configured to trigger different inertial events. Among them it is worth mentioning the recognition of Free-Fall and Wake-Up events. Whenever an interrupt condition is verified the interrupt signal is asserted and reading either the FF_WU_SRC_1 or FF_WU_SRC_2 registers it is possible to understand which condition has occurred.

The block diagram of the interrupt block is given in the pictures below.

Figure 13. Interrupt Generation Block Diagram

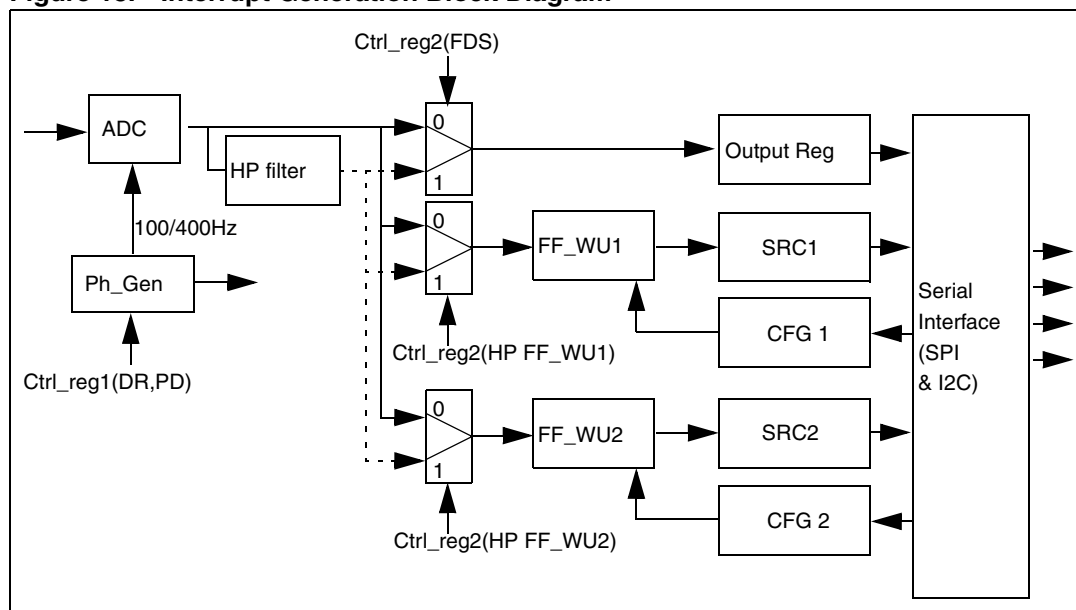
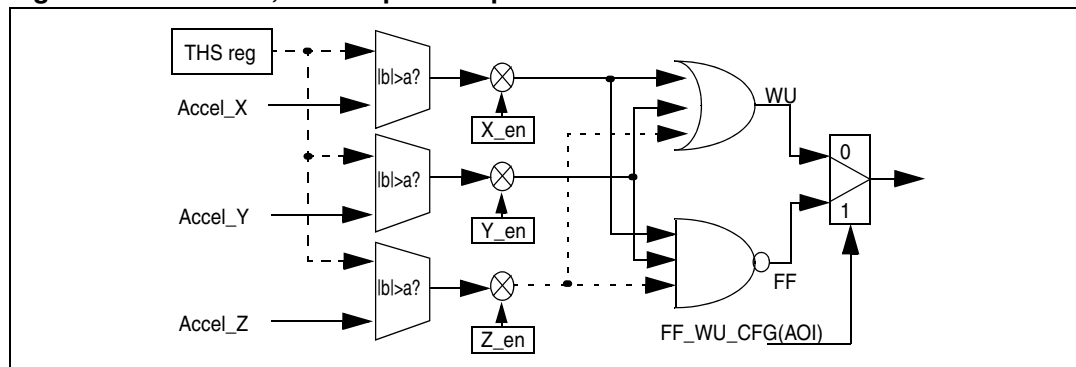

Figure 14. Free-Fall, Wake-Up Interrupt Generator



FF or WU interrupt generation is selected for each interrupt generation channel through AOI bit in the corresponding FF_WU_CFG register. If AOI bit is '0' signals coming from comparators are put in logical or. Depending on values written in FF_WU_CFG_1 and FF_WU_CFG_2 registers every time the value of at least one of the enabled axes exceeds the threshold written in module in the corresponding FF_WU_THS_1 and FF_WU_THS_2 registers a FF, WU interrupt is generated. Otherwise if AOI bit is '1' signals coming from comparators are going into a "NAND" port. In this case an interrupt signal is generated whenever the acceleration signal of all the enabled axes is below the threshold written in FF_WU_THS_1 or FF_WU_THS_2 registers.

FF_WU_CFG(LIR) bit permits to decide if the interrupt request has to be latched or not. If LIR bit is '0' (default value) interrupt signal goes high when the interrupt condition is satisfied and comes back low immediately if the interrupt condition is no more verified. Otherwise if LIR bit is '1' whenever a interrupt condition is applied the interrupt signal remains high even if the condition comes back to non-interrupt status until a reading to FF_WU_SRC register is performed.

The remaining bits of FF_WU_CFG register permits to decide on which axis the interrupt decision has to be performed and on which direction the threshold has to be passed to generate the interrupt request.

9.5 INERTIAL WAKE-UP

9.5.1 HP Filter Bypassed

This paragraph provides a basic algorithm which shows the practical use of the inertial wake-up feature. In particular, with the code below, the device is configured to recognize when the absolute acceleration along either X or Y axis exceeds a preset threshold (180mg used in the example). The event which triggers the interrupt is latched inside the device using FF_WU interrupt source 1 and its occurrence is signalled through the usage of the INT2 pin.

```

1  write C7h into CTRL_REG1           // Turn on the sensor and set ODR=400Hz
2  write 00h into CTRL_REG2         // Default value: High Pass filter bypassed
3  write 08h into CTRL_REG3         // FF_WU1 interrupt sent to INT2 pin
4  write 0Ah into FF_WU_THS_1 reg    // Set wake-up threshold = 180 mg
5  write 00h into FF_WU_DURATION_1 reg // No filtering/confirmation on the event
6  write 4Ah into FF_WU_CFG_1       // Configure desired wake-up event
7  poll INT2 pin; if INT2=0 then goto 7 // Poll INT2 pin waiting for the wake-up event
                                     // Return the event that has triggered the
8  read FF_WU_SRC_1 reg             interrupt
                                     // Clear interrupt request
                                     // Event handling
9  (Wake-up event has occurred; insert your code here)
10 goto 7

```

9.5.2 Using the HP Filter

The code provided below gives a basic routine which shows the practical use of the inertial wake-up feature performed onto high-pass filtered data. In particular the device is configured to recognize when the high-frequency component of the acceleration applied along either X, Y or Z axis exceeds a preset threshold (180mg used in the example). The event which triggers the interrupt is latched inside the device using FF_WU interrupt source 1 and its occurrence is signalled through the usage of the INT1 pin.

```

1  write C7h into CTRL_REG1           // Turn on the sensor and set ODR=400 Hz
2  write 04h into CTRL_REG2           // High Pass filter enabled on FF_WU1, fcut-
                                     // off= 8Hz
3  write 01h into CTRL_REG3           // FF_WU1 interrupt sent to INT1 pin
4  write 0Ah into FF_WU_THS_1 reg     // Set wake-up threshold = 180 mg
5  write 00h into FF_WU_DURATION_1 reg // No filtering/confirmation on the event
                                     // Dummy read to force the HP filter to
6  read HP_FILTER_RESET register      // actual acceleration value
                                     // (i.e. set reference acceleration/tilt value)
7  write 6Ah into FF_WU_CFG_1         // Configure desired wake-up event
8  poll INT1 pin; if INT1=0 then goto 7 // Poll INT1 pin waiting for the wake-up event
9  (Wake-up event has occurred; insert your code // Event handling
   here)
10 read FF_WU_SRC_1 reg               // Return the event that has triggered the
                                     // interrupt
                                     // Clear interrupt request
11 (Insert your code here)           // Event handling
12 goto 8

```

At step 6, a dummy read at HP_FILTER_RESET register is performed to set the current/reference acceleration/tilt state against which the device performed the threshold comparison.

This read may be performed any time it is required to set the orientation/tilt of the device as a reference state without waiting for the filter to settle.

9.6 Free-Fall Detection

9.6.1 Roll function not used

This paragraph provides the basics for the use of the free-fall detection feature. In particular the SW routine that configures the device to detect free-fall events and to signal them is the following:

```
1  write 47h into CTRL_REG1           // Turn on the sensor and set ODR=100 Hz
2  write 00h into CTRL_REG2           // Default value: High Pass filter bypassed
3  write 08h into CTRL_REG3           // FF_WU1 interrupt sent to INT2 pin
4  write 14h into FF_WU_THS_1 reg      // Set the free-fall threshold
5  write 09h into FF_WU_DURATION_1 reg // Set minimum event duration to 90 msec
6  write D5h into FF_WU_CFG_1         // Configure free-fall recognition and latch
                                       // interrupt request
7  poll INT2 pad; if INT2=0 then goto 7 // Poll INT2 pin waiting for the free-fall event
8  (Free-fall event has occurred; insert your code here) // Event handling
9  read FF_WU_SRC_1 register          // Clear interrupt request
10 goto 7
```

The code sample exploits a threshold set at 350mg for free-fall recognition and the event is notified by the hardware signal INT2 pin. At step 5, the FF_WU_DURATION_1 register is configured so to ignore events that are shorter than $9/ODR=9/100\sim 90\text{msec}$ (ODR=output data rate) in order to avoid false detections.

Once the free-fall event has occurred, a dummy read at FF_WU_SRC_1 reg clears the request and the device is ready to recognize other events.

9.6.2 Roll function applied

Roll function can be added to free-fall condition recognition using both interrupt sources. Interrupt signals can be sent to two different pins (INT1, INT2) or can be sent to the same so that the first condition that is verified take control of the pin (logic "OR" of interrupt signals).

9.7 Output data rate selection and reading timing

The output data rate is user selectable through DR bit stored in CTRL_REG1 (20h) register. At power-on-reset DR is reset to 0 thus providing a default output data rate set to 100 Hz.

The selectable output data rate are given in table below:

Table 6. Output Data Rate

DR	Output data rate
0	100 Hz
1	400 Hz

The output data rate precision is related to internal oscillator or to external clock precision and an error of +/- 10% should be taken in account.

The output data rate precision is related to internal oscillator or to external clock precision and an error of +/- 10% should be taken in account.

A minimum reading period 150 μ s shorter than the output data rate period is defined not to loose any data produced. During this time period the reading of the data must be performed and DataReady signal can be used as a trigger to begin the reading sequence. At the end of the complete sequence DataReady signal goes down and the following rise edge advise that new data are available. If this minimum reading frequency is not observed it is possible to loose some data and the DataReady signal have no more the meaning of a trigger signal. The status register can be used to infer whether an overrun condition has happened.

Figure 15. Reading Timing

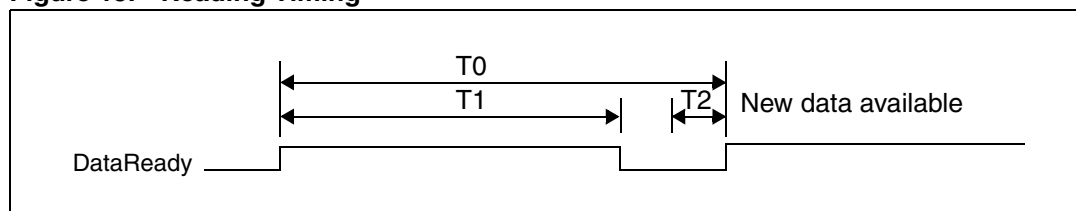

Table 7. Timing Value to Avoid Loosing the Data

Time	Description	Min	Typ	Max
T0	Data rate	2.5 ms		10 ms
T1	Reading period			T0-T2
T2	New data generation	150 μ s		

9.8 Data ready vs. interrupt signal

The device is provided with two pins which can be activated to generate either the DataReady or the interrupt signal. The functionality of the pins are selected acting on interrupt configuration bit located in Ctrl_Reg3(2-0) for interrupt pin 1 (INT1) and in Ctrl_Reg3(5-3) for interrupt pin 2 (INT2) accordingly to the block diagram given in [Figure 16](#).

In particular the DataReady signal, stored in Status_Reg(3), which indicates when a new set of acceleration data is ready, is made available by setting cfg bit to 100, while the interrupt source 1 signal is carried out when cfg bit are set to 001 and interrupt source 2 when cfg bit are set to 010. A Logic "OR" combination of interrupt source 1 and 2 can be sent to an interrupt pin writing 011 in cfg bit.

Figure 16. Interrupt and dataready signal generation block diagram

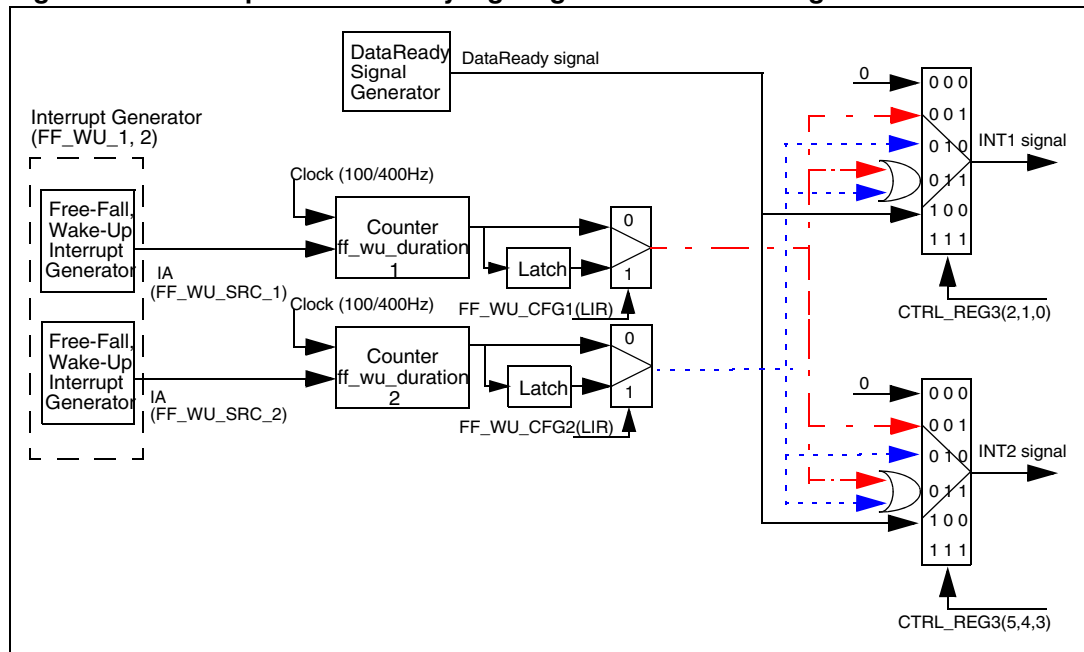

The Data-ready signal is risen to 1 when a new set of acceleration data has been generated and it is available for reading. The signal is reset after all the enabled channels are read through the serial interface.

Figure 17. Data Ready Signal

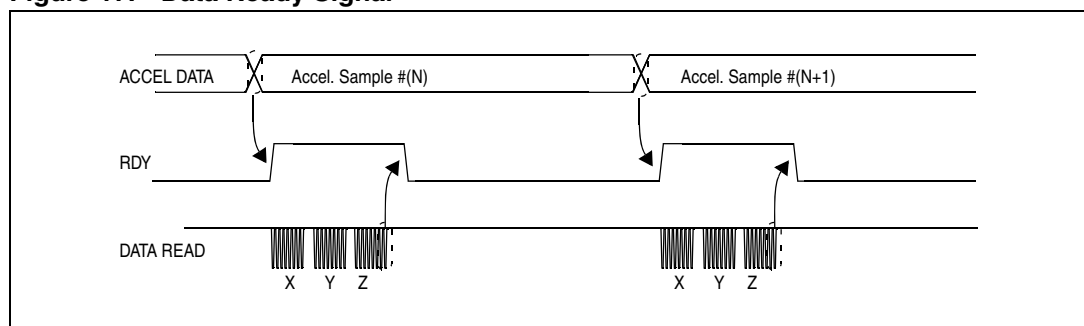

10 Revision history

Table 8. Document revision history

Date	Revision	Changes
03-Aug-2006	1	Initial release.
20-Oct-2006	2	Changes in the pages 8, 18 & 21.

Please Read Carefully:

Information in this document is provided solely in connection with ST products. STMicroelectronics NV and its subsidiaries ("ST") reserve the right to make changes, corrections, modifications or improvements, to this document, and the products and services described herein at any time, without notice.

All ST products are sold pursuant to ST's terms and conditions of sale.

Purchasers are solely responsible for the choice, selection and use of the ST products and services described herein, and ST assumes no liability whatsoever relating to the choice, selection or use of the ST products and services described herein.

No license, express or implied, by estoppel or otherwise, to any intellectual property rights is granted under this document. If any part of this document refers to any third party products or services it shall not be deemed a license grant by ST for the use of such third party products or services, or any intellectual property contained therein or considered as a warranty covering the use in any manner whatsoever of such third party products or services or any intellectual property contained therein.

UNLESS OTHERWISE SET FORTH IN ST'S TERMS AND CONDITIONS OF SALE ST DISCLAIMS ANY EXPRESS OR IMPLIED WARRANTY WITH RESPECT TO THE USE AND/OR SALE OF ST PRODUCTS INCLUDING WITHOUT LIMITATION IMPLIED WARRANTIES OF MERCHANTABILITY, FITNESS FOR A PARTICULAR PURPOSE (AND THEIR EQUIVALENTS UNDER THE LAWS OF ANY JURISDICTION), OR INFRINGEMENT OF ANY PATENT, COPYRIGHT OR OTHER INTELLECTUAL PROPERTY RIGHT.

UNLESS EXPRESSLY APPROVED IN WRITING BY AN AUTHORIZED ST REPRESENTATIVE, ST PRODUCTS ARE NOT RECOMMENDED, AUTHORIZED OR WARRANTED FOR USE IN MILITARY, AIR CRAFT, SPACE, LIFE SAVING, OR LIFE SUSTAINING APPLICATIONS, NOR IN PRODUCTS OR SYSTEMS WHERE FAILURE OR MALFUNCTION MAY RESULT IN PERSONAL INJURY, DEATH, OR SEVERE PROPERTY OR ENVIRONMENTAL DAMAGE. ST PRODUCTS WHICH ARE NOT SPECIFIED AS "AUTOMOTIVE GRADE" MAY ONLY BE USED IN AUTOMOTIVE APPLICATIONS AT USER'S OWN RISK.

Resale of ST products with provisions different from the statements and/or technical features set forth in this document shall immediately void any warranty granted by ST for the ST product or service described herein and shall not create or extend in any manner whatsoever, any liability of ST.

ST and the ST logo are trademarks or registered trademarks of ST in various countries.

Information in this document supersedes and replaces all information previously supplied.

The ST logo is a registered trademark of STMicroelectronics. All other names are the property of their respective owners.

© 2006 STMicroelectronics - All rights reserved

STMicroelectronics group of companies

Australia - Belgium - Brazil - Canada - China - Czech Republic - Finland - France - Germany - Hong Kong - India - Israel - Italy - Japan - Malaysia - Malta - Morocco - Singapore - Spain - Sweden - Switzerland - United Kingdom - United States of America

www.st.com