



2STF1360 2STN1360

LOW VOLTAGE FAST-SWITCHING NPN POWER TRANSISTORS

Features

- VERY LOW COLLECTOR-EMITTER SATURATION VOLTAGE
- HIGH CURRENT GAIN CHARACTERISTIC
- FAST-SWITCHING SPEED
- IN COMPLIANCE WITH THE 2002/93/EC EUROPEAN DIRECTIVE
- SURFACE MOUNTING DEVICES IN MEDIUM POWER SOT-223 AND SOT-89 PACKAGES
- AVAILABLE IN TAPE & REEL PACKING

Applications

- EMERGENCY LIGHTING
- LED
- CCFL DRIVERS (BACK LIGHTING)
- VOLTAGE REGULATION
- RELAY DRIVER

Description

The 2STF1360 and 2STN1360 are NPN transistors manufactured using new "PB-HDC" (Power Bipolar High Density Current) technology. The resulting transistor shows exceptional high gain performances coupled with very low saturation voltage.

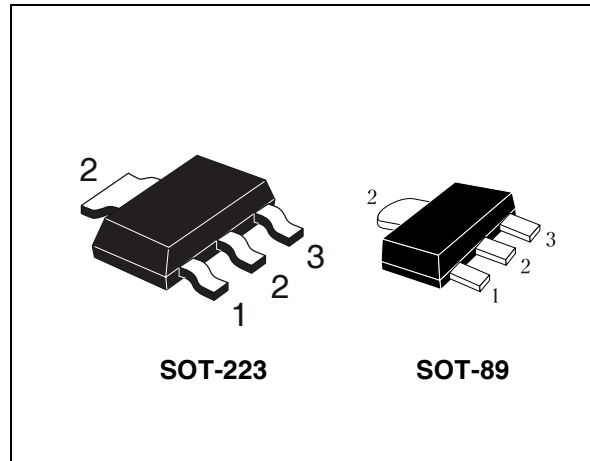

Internal Schematic Diagram

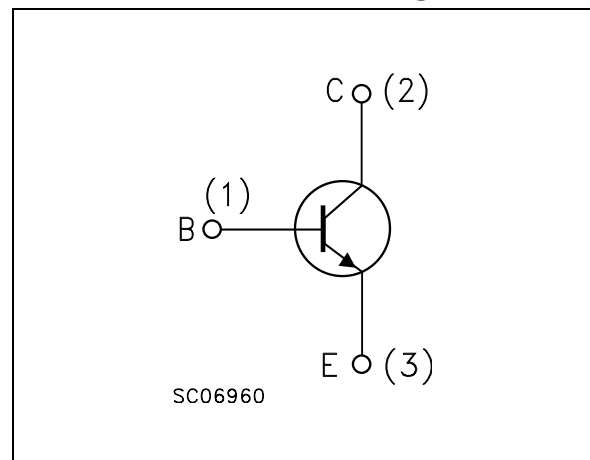

Order Codes

Part Number	Marking	Package	Packing
2STF1360	1360	SOT-89	Tape & Reel
2STN1360	N1360	SOT-223	Tape & Reel

1 Absolute Maximum Ratings

Table 1. Absolute Maximum Rating

Symbol	Parameter	Value		Unit
		2STF1360	2STN1360	
		SOT-89	SOT-223	
V_{CB0}	Collector-Base Voltage ($I_E = 0$)	80		V
V_{CEO}	Collector-Emitter Voltage ($I_B = 0$)	60		V
V_{EBO}	Emitter-Base Voltage ($I_C = 0$)	6		V
I_C	Collector Current	3		A
I_{CM}	Collector Peak Current ($t_P < 5\text{ms}$)	5		A
I_B	Base Current	0.2		A
I_{BM}	Base Peak Current ($t_P < 5\text{ms}$)	0.4		A
P_{TOT}	Total dissipation at $T_C = 25^\circ\text{C}$	1.4	1.6	W
T_{stg}	Storage Temperature	-65 to 150		$^\circ\text{C}$
T_J	Max. Operating Junction Temperature	150		$^\circ\text{C}$

Table 2. Thermal Data

Symbol	Parameter	SOT-89	SOT-223	
$R_{thJ-amb}^{\#}$	Thermal Resistance Junction-Ambient Max	89	78	$^\circ\text{C}/\text{W}$

Note: $\#$ Device mounted on a PCB area of 1 cm^2 .

2 Electrical Characteristics

Table 3. Electrical Characteristics ($T_{CASE} = 25^{\circ}C$; unless otherwise specified)

Symbol	Parameter	Test Conditions	Min.	Typ.	Max.	Unit
I_{CBO}	Collector Cut-off Current ($I_E = 0$)	$V_{CB} = 80\text{ V}$			100	nA
I_{EBO}	Emitter Cut-off Current ($I_C = 0$)	$V_{EB} = 6\text{ V}$			100	nA
V_{BE}	Base-Emitter Voltage	$V_{CE} = 2\text{ V}$ $I_C = 100\text{ mA}$	630	670	730	mV
$V_{CE(sat)}$ <i>Note: 1</i>	Collector-Emitter Saturation Voltage	$I_C = 2\text{ A}$ $I_B = 100\text{ mA}$ $I_C = 3\text{ A}$ $I_B = 150\text{ mA}$		150 210	300 500	mV mV
$V_{BE(sat)}$ <i>Note: 1</i>	Base-Emitter Saturation Voltage	$I_C = 2\text{ A}$ $I_B = 100\text{ mA}$		0.89	1.2	V
h_{FE} <i>Note: 1</i>	DC Current Gain	$I_C = 100\text{ mA}$ $V_{CE} = 2\text{ V}$ $I_C = 1\text{ A}$ $V_{CE} = 2\text{ V}$	80 160	280	400	
t_d t_r t_s t_f	RESISTIVE LOAD Delay Time Rise Time Storage Time Fall Time	$V_{CC} = 10\text{ V}$ $I_C = 3\text{ A}$ $I_{B1} = - I_{B2} = 300\text{ mA}$ (see figure 8)		17 81 620 54	20 100 720 65	ns ns ns ns
f_T	Transition Frequency	$I_C = 0.1\text{ A}$ $V_{CE} = 10\text{ V}$		130		MHz

Note: 1 Pulsed duration = 300 μ s, duty cycle $\leq 1.5\%$.

2.1 Typical Characteristics

Figure 1. DC Current Gain

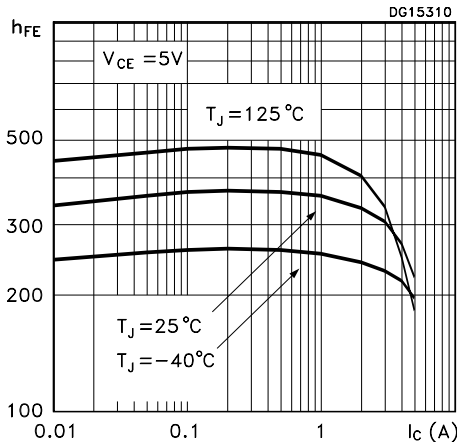

Figure 2. DC Current Gain

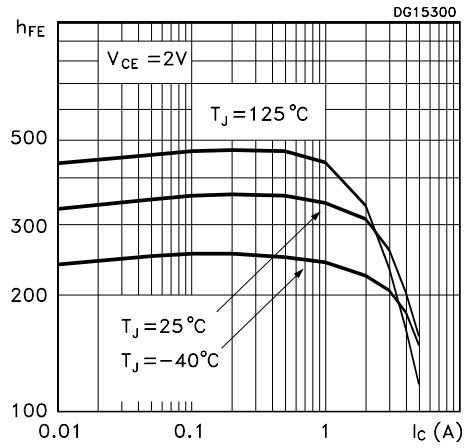

Figure 3. Collector Emitter Saturation Voltage Figure 4. Base Emitter Saturation Voltage

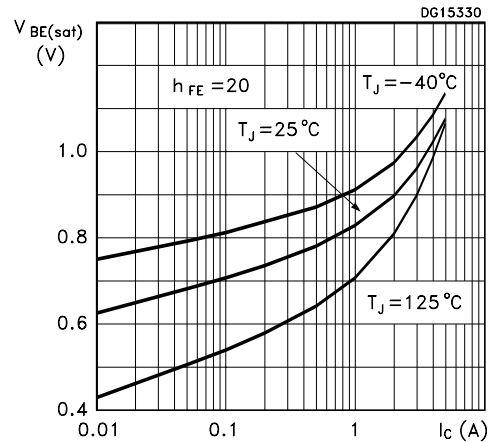
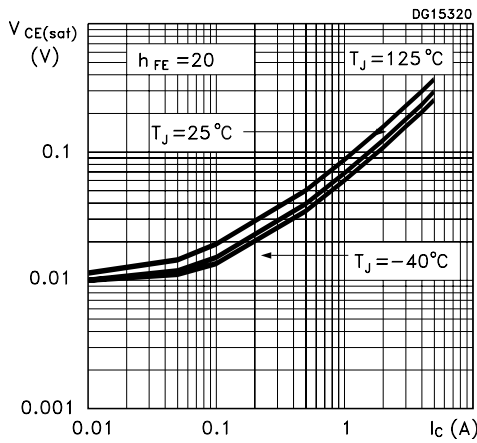

Figure 5. Resistive Load Switching Times

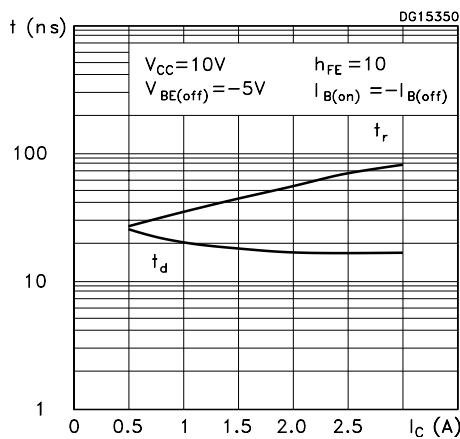

Figure 6. Resistive Load Switching Times

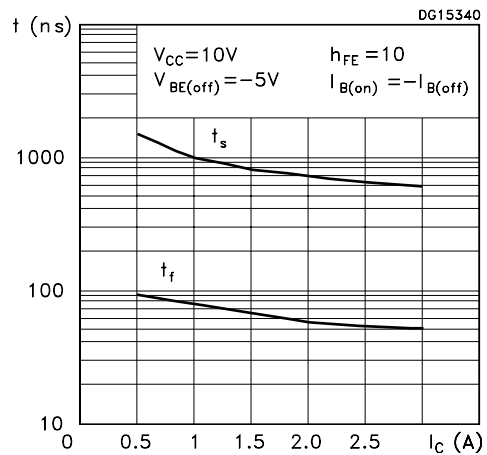
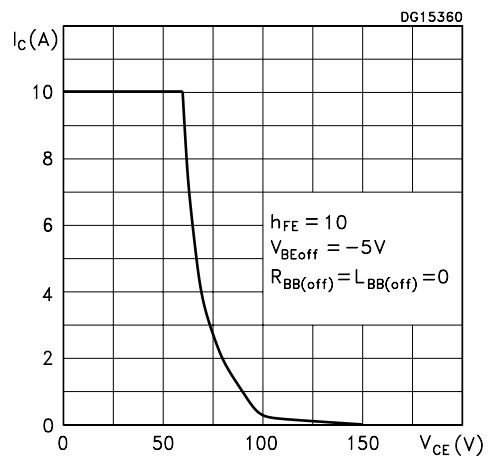
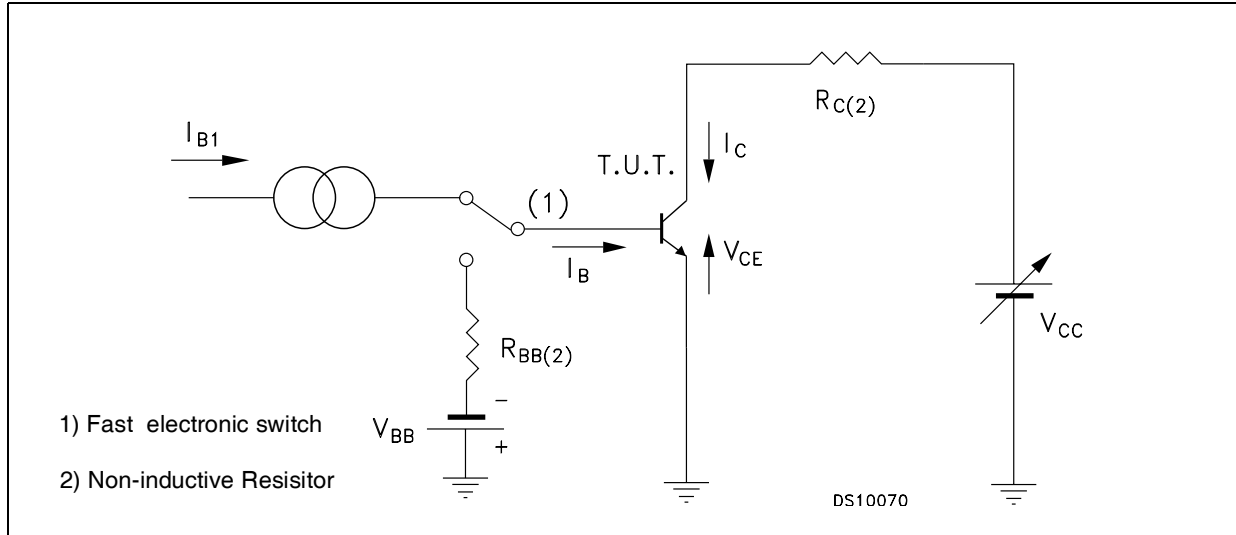

Figure 7. Reverse Biased SOA



3 Test Circuits

Figure 8. Resistive Load Switching Test Circuit



4 Package Mechanical Data

In order to meet environmental requirements, ST offers these devices in ECOPACK® packages. These packages have a Lead-free second level interconnect . The category of second level interconnect is marked on the package and on the inner box label, in compliance with JEDEC Standard JESD97. The maximum ratings related to soldering conditions are also marked on the inner box label. ECOPACK is an ST trademark. ECOPACK specifications are available at: www.st.com

SOT-89 MECHANICAL DATA

DIM.	mm			mils		
	MIN.	TYP.	MAX.	MIN.	TYP.	MAX.
A	1.4		1.6	55.1		63.0
B	0.44		0.56	17.3		22.0
B1	0.36		0.48	14.2		18.9
C	0.35		0.44	13.8		17.3
C1	0.35		0.44	13.8		17.3
D	4.4		4.6	173.2		181.1
D1	1.62		1.83	63.8		72.0
E	2.29		2.6	90.2		102.4
e	1.42		1.57	55.9		61.8
e1	2.92		3.07	115.0		120.9
H	3.94		4.25	155.1		167.3
L	0.89		1.2	35.0		47.2

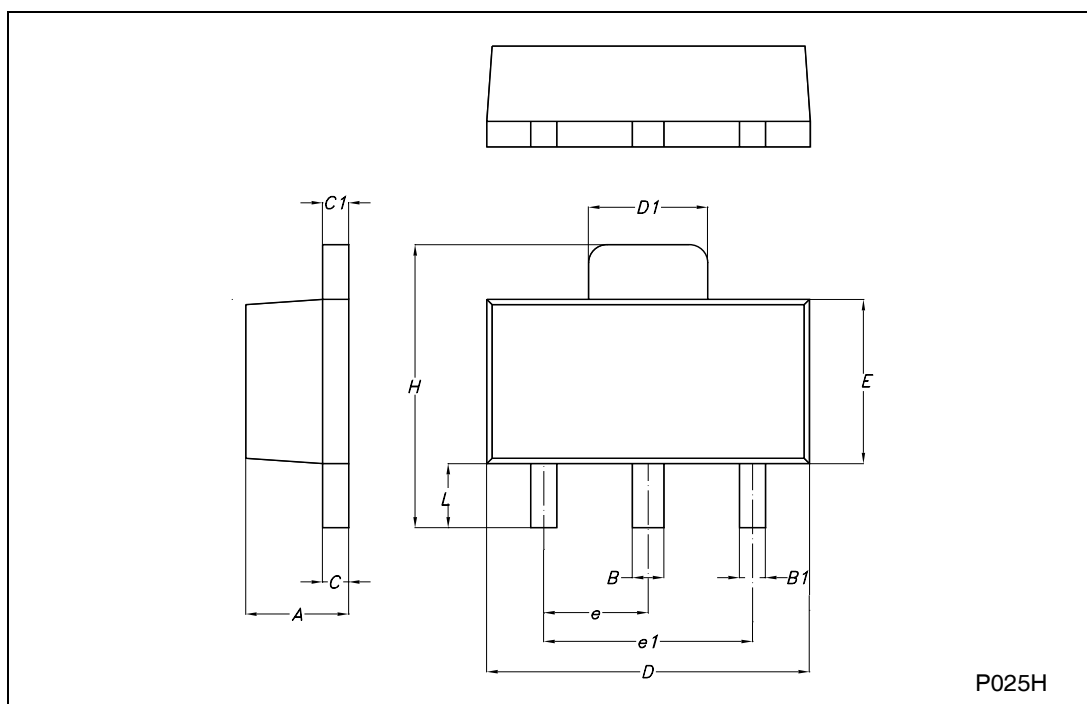

SOT-223 MECHANICAL DATA

DIM.	mm			inch		
	MIN.	TYP.	MAX.	MIN.	TYP.	MAX.
A			1.80			0.071
B	0.60	0.70	0.80	0.024	0.027	0.031
B1	2.90	3.00	3.10	0.114	0.118	0.122
c	0.24	0.26	0.32	0.009	0.010	0.013
D	6.30	6.50	6.70	0.248	0.256	0.264
e		2.30			0.090	
e1		4.60			0.181	
E	3.30	3.50	3.70	0.130	0.138	0.146
H	6.70	7.00	7.30	0.264	0.276	0.287
V			10°			10°
A1		0.02				

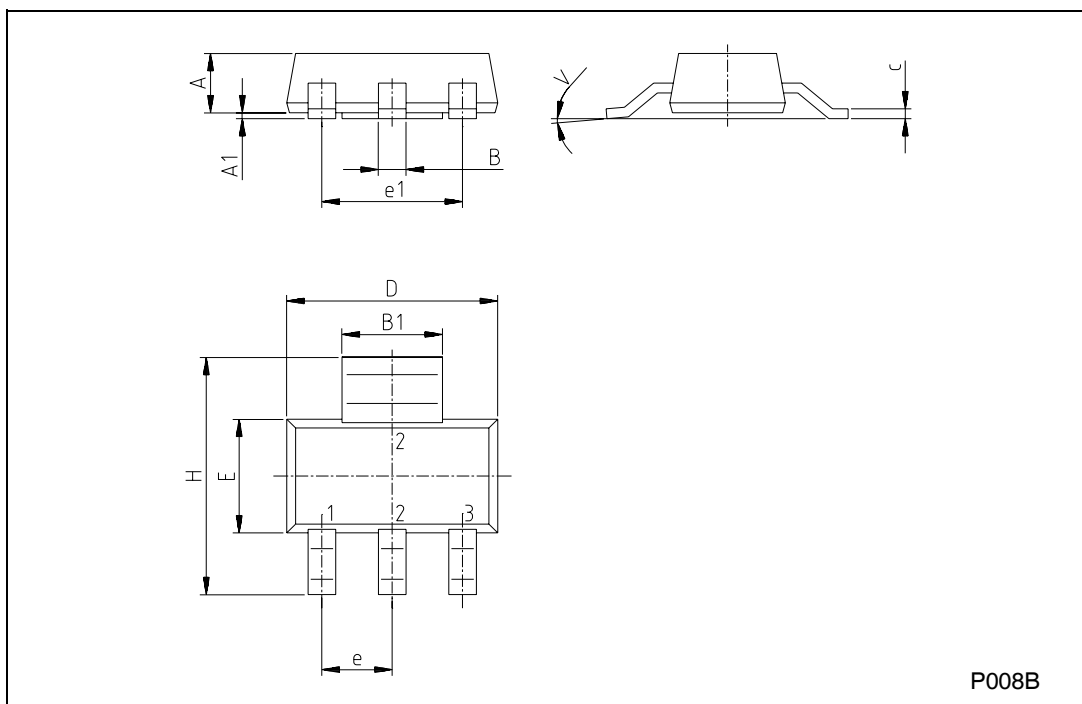

5 Revision History

Date	Revision	Changes
21-Nov-2005	1	Initial Release

Information furnished is believed to be accurate and reliable. However, STMicroelectronics assumes no responsibility for the consequences of use of such information nor for any infringement of patents or other rights of third parties which may result from its use. No license is granted by implication or otherwise under any patent or patent rights of STMicroelectronics. Specifications mentioned in this publication are subject to change without notice. This publication supersedes and replaces all information previously supplied. STMicroelectronics products are not authorized for use as critical components in life support devices or systems without express written approval of STMicroelectronics.

The ST logo is a registered trademark of STMicroelectronics.
All other names are the property of their respective owners

© 2005 STMicroelectronics - All rights reserved

STMicroelectronics group of companies

Australia - Belgium - Brazil - Canada - China - Czech Republic - Finland - France - Germany - Hong Kong - India - Israel - Italy - Japan -
Malaysia - Malta - Morocco - Singapore - Spain - Sweden - Switzerland - United Kingdom - United States of America

www.st.com

