

Silicon Switching Diode Array

BAW 101

- Electrically insulated high-voltage medium-speed diodes

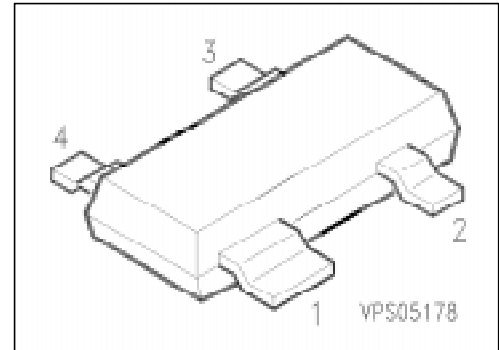

Type	Marking	Ordering Code (tape and reel)	Pin Configuration	Package ¹⁾
BAW 101	JPs	Q62702-A712		SOT-143

Maximum Ratings

Parameter	Symbol	Values	Unit
Reverse voltage	V_R	300	V
Peak reverse voltage	V_{RM}	300	
Forward current	I_F	250	mA
Peak forward current	I_{FM}	500	
Surge forward current, $t = 1 \mu s$	I_{FS}	4.5	A
Total power dissipation, $T_s \leq 35 \text{ }^\circ\text{C}$	P_{tot}	350	mW
Junction temperature	T_j	150	$^\circ\text{C}$
Storage temperature range	T_{stg}	- 65 ... + 150	

Thermal Resistance

Junction - ambient ²⁾	$R_{th JA}$	≤ 470	K/W
Junction - soldering point	$R_{th JS}$	≤ 330	

¹⁾ For detailed information see chapter Package Outlines.

²⁾ Package mounted on epoxy pcb 40 mm × 40 mm × 1.5 mm/6 cm² Cu.

Electrical Characteristics

at $T_A = 25\text{ }^\circ\text{C}$, unless otherwise specified.

Parameter	Symbol	Values			Unit
		min.	typ.	max.	

DC characteristics

Breakdown voltage $I_{(BR)} = 100\text{ }\mu\text{A}$	$V_{(BR)}$	300	–	–	V
Forward voltage $I_F = 100\text{ mA}$	V_F	–	–	1.3	
Reverse current $V_R = 250\text{ V}$ $V_R = 250\text{ V}, T_A = 150\text{ }^\circ\text{C}$	I_R	–	–	150 50	nA μA

AC characteristics

Diode capacitance $V_R = 0, f = 1\text{ MHz}$	C_D	–	6	–	pF
Reverse recovery time $I_F = 10\text{ mA}, I_R = 10\text{ mA}, R_L = 100\text{ }\Omega$ measured at $I_R = 1\text{ mA}$	t_{rr}	–	1	–	μs

Test circuit for reverse recovery time

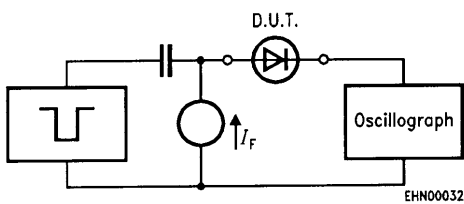

Pulse generator: $t_p = 100\text{ ns}, D = 0.05$
 $t_r = 0.6\text{ ns}, R_j = 50\text{ }\Omega$

Oscilloscope: $R = 50\text{ }\Omega$
 $t_r = 0.35\text{ ns}$
 $C \leq 1\text{ pF}$

Forward current $I_F = f(T_A^*; T_S)$

* Package mounted on epoxy

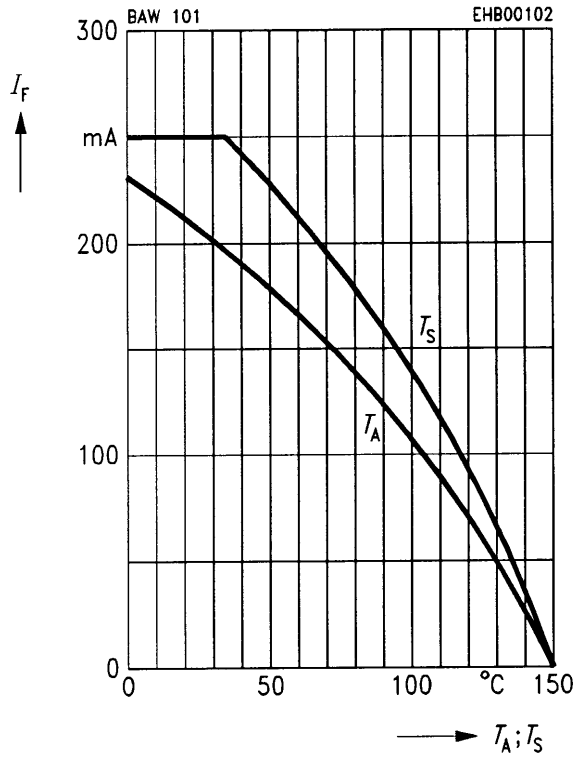

Forward current $I_F = f(V_F)$

$T_A = 25\text{ °C}$

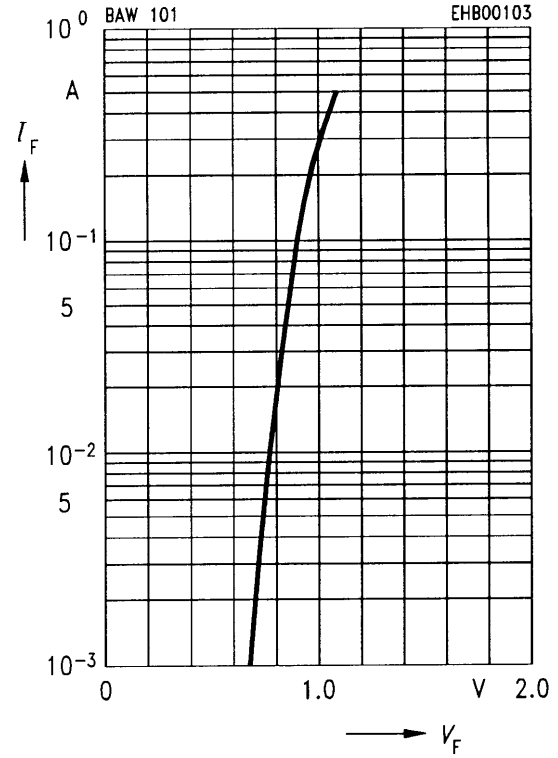

Reverse current $I_R = f(T_A)$

