

# 4-channel BTL driver for CD players

## BA6392FP

The BA6392FP is a 4-channel BTL driver for CD player motors and actuators. It has an internal primary filter, and can be directly connected (without attached components) to the servo PWM output of all drivers other than the spindle driver. The BA6392FP is pin compatible with the BA6297AFP.

### ●Applications

CD players, CD-ROM drives

### ●Features

- 1) HSOP 28-pin package allows for miniaturization of applications.
- 2) PWM input is filtered by the internal primary filter, eliminating the need for attached resistors and capacitors, thereby helping reduce the number of components. Resistor and capacitor time constants can also be changed with attached components.
- 3) Internal thermal shutdown circuit.
- 4) Internal mute circuit.

### ●Absolute maximum ratings (Ta = 25°C)

Parameter	Symbol	Limits	Unit
Power supply voltage	V <sub>CC</sub>	18	V
Power dissipation	P <sub>d</sub>	1.7*1	W
Operating temperature	T <sub>opr</sub>	-30~+85	°C
Storage temperature	T <sub>stg</sub>	-55~+150	°C

\*1 Reduced by 13.6 mW for each increase in Ta of 1°C over 25°C.  
When mounted on a 50 × 50 × 1.0 mm phenol paper PCB.

### ●Recommended operating conditions (Ta = 25°C)

Parameter	Symbol	Limits	Unit
Power supply voltage	V <sub>CC</sub>	6~16*2	V

\*2 Set the power supply voltage according to power dissipation.

●Block diagram

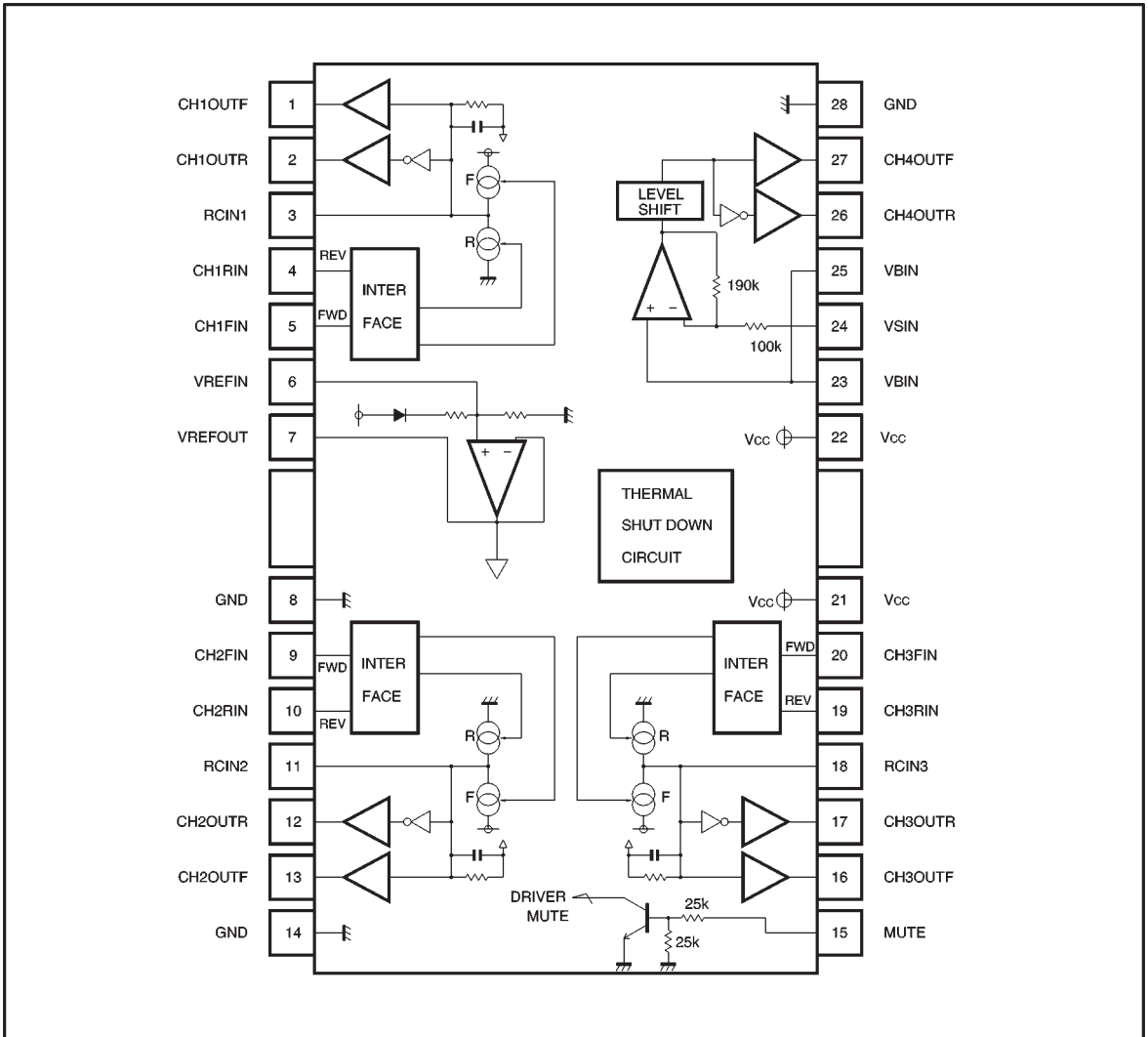

## ● Pin descriptions

Pin No.	Pin name	Function
1	CH1OUT F	Driver channel 1 forward output
2	CH1OUT R	Driver channel 1 reverse output
3	RC IN1	Connect to attached resistor/capacitor (1)
4	CH1 RIN	Driver channel 1 reverse input
5	CH1 FIN	Driver channel 1 forward input
6	VREF IN	Internal reference amplifier input
7	VREF OUT	Internal reference amplifier output
8	GND	Ground for internal reference and internal power circuit
9	CH2 FIN	Driver channel 2 forward input
10	CH2 RIN	Driver channel 2 reverse input
11	RC IN2	Connect to attached resistor/capacitor (2)
12	CH2OUT R	Driver channel 2 reverse output
13	CH2OUT F	Driver channel 2 forward output
14	GND	Ground
15	MUTE	Driver mute control input
16	CH3OUT F	Driver channel 3 forward output
17	CH3OUT R	Driver channel 3 reverse output
18	RC IN3	Connect to attached resistor/capacitor (3)
19	CH3 RIN	Driver channel 3 reverse input
20	CH3 FIN	Driver channel 3 forward input
21	V <sub>CC</sub>	Power supply
22	V <sub>CC</sub>	Power supply
23	VBIN	Driver channel 4 bias input*
24	VSIN	Driver channel 4 input
25	VBIN	Driver channel 4 bias input*
26	CH4OUT R	Driver channel 4 reverse output
27	CH4OUT F	Driver channel 4 forward output
28	GND	Ground

\* Pin 23 and pin 25 are shorted internally.

## ●Electrical characteristics (unless otherwise noted, Ta = 25°C, Vcc = 8V, f = 1kHz, RL = 8Ω)

Parameter	Symbol	Min.	Typ.	Max.	Unit	Conditions
Quiescent current	I <sub>Q</sub>	8	13	18	mA	No load
Bias pin voltage	V <sub>BIAS</sub>	3.40	3.70	4.00	V	
Bias pin voltage variance	ΔV <sub>BIAS</sub>	−30	—	30	mV	1 mA Source, sink
Mute-off voltage	V <sub>MON</sub>	2.0	—	—	V	
Mute-on voltage	V <sub>MOFF</sub>	—	—	0.5	V	
〈Drivers (other than spindle)〉						
Input high level voltage	V <sub>IH</sub>	2.4	—	—	V	
Input low level voltage	V <sub>IL</sub>	—	—	0.5	V	
Input high level current	I <sub>IH</sub>	170	310	450	μA	V <sub>IN</sub> =5V
Input low level current	I <sub>IL</sub>	−10	—	0	μA	V <sub>IN</sub> =0V
Output voltage, offset	V <sub>OO</sub>	−30	—	30	mV	(same for spindle)
Output high level voltage	V <sub>OHD</sub>	5.2	5.6	—	V	F <sub>IN</sub> =5V, R <sub>IN</sub> =0V
Output low level voltage	V <sub>OLD</sub>	—	1.3	1.6	V	F <sub>IN</sub> =0V, R <sub>IN</sub> =5V
Constant current	I <sub>CONST</sub>	14	22	30	μA	
Internal integral capacitance	C	—	24	—	pF	
Current pulse rise time 1	Δtr	—	0.08	1	μs	At startup
Current pulse fall time 2	Δtf	—	0.55	1	μs	At shutdown
Current pulse time differential	Δtr−f	−160	—	160	μs	
Drive linearity	LIN	90	100	110	%	V <sub>IN</sub> =V <sub>REF</sub> ±0.5, 1, 1.5V*1
Ripple rejection	RR	—	70	—	dB	V <sub>IN</sub> =100mV <sub>rms</sub> , 100Hz
〈Spindle driver〉						
Input bias current	I <sub>B</sub>	—	10	300	nA	
Synchronous input voltage	V <sub>ICM</sub>	1.6	—	6.4	V	
Max. output voltage high	V <sub>OHD</sub>	5.2	5.6	—	V	
Max. output voltage low	V <sub>OLD</sub>	—	1.3	1.55	V	
Voltage gain	G <sub>VC</sub>	8.0	10.5	13.0	dB	
Slew rate	SR	—	2	—	V / μs	
Ripple rejection	RR <sub>S</sub>	—	70	—	dB	V <sub>IN</sub> =100mV <sub>rms</sub> , 100Hz

© Not designed for radiation resistance.

\*1 If Vo = V01 when V<sub>IN</sub> = V<sub>REF</sub> ±0.5 V, Vo = V02 when V<sub>IN</sub> = V<sub>REF</sub> ±1.0 V, and Vo = V3 when V<sub>IN</sub> = V<sub>REF</sub> ±1.5 V,

then LIN = (V03 - V02)/(V02 - V01) × 100%.

● Input / output circuits

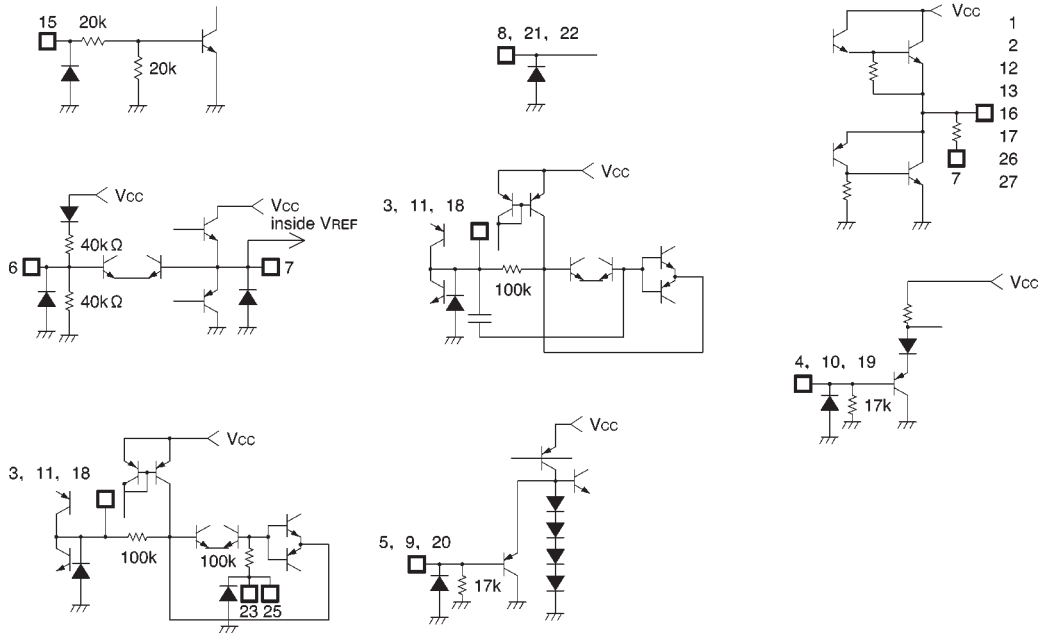

Fig. 1

● Circuit operation

(1) Fig. 3 shows the inputs from the digital servo IC for CH1-CH3 drivers (all drivers except the spindle). SW1 is on when the forward input signal (HIGH level, over 2.4V) is present. SW2 is on when the reverse input signal is present (Fig. 2)

The constant current ( $I_1$ ) at this time enters the RC and generates an integral waveform based on the duty of the input waveform. The BTL is output from BUF1 and BUF2 (Fig. 4).

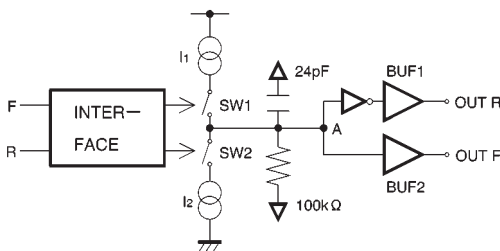

Fig. 2

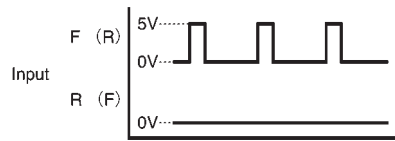

Fig. 3

To maintain the HIGH level with forward (or reverse) input, the DC voltage generated at point A is :

$$I_1 \times R \approx 2.5V \text{ (reverse : } -2.5V)$$

This is the voltage generated relative  $V_{REF}$ . The setting is such that a voltage differential of 5V is generated between output pins. The time constant is :

$$R \times C = 2.4\mu\text{sec}$$

This can be increased by inserting a capacitor between point A (pins 3, 11 and 18) and  $V_{REF}$ . The constant current ( $I_{const}$ ) given in the electrical characteristics refers to  $I_1$  and  $I_2$  in Fig. 2.

F	R	SW1	SW2
L	L	OFF	OFF
L	H	OFF	ON
H	L	ON	OFF
H	H	OFF	OFF

H • • • 2.4V Max.

L • • • 0.5V Min.

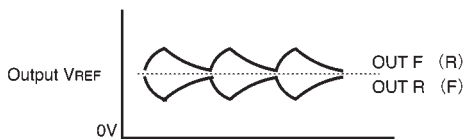

Fig. 4

## (2) CH4 driver (spindle driver)

Pins 23 and 25 are shorted inside the IC. Bias amplitudes are the primary type of inputs assumed. The level shift circuit converts the pre-stage amplifier output (centered on the bias level and impressed on pins 23 and 25) to positive and negative amplitudes centered on  $V_{REF}$ . The level shift circuit's output is BTL-output from the buffer amplifier.

Because of the high input impedance, the IC is designed to accommodate a filter comprising attached resistors and capacitors.

(Example) For secondary filters

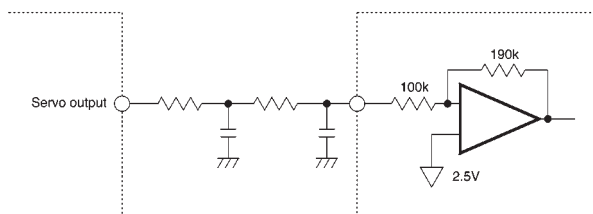

Fig. 5

## ● Operation notes

- (1) The BA6392FP has an internal thermal shutdown circuit. Output current is muted when the chip temperature exceeds 180°C (typically).
- (2) The output current can also be muted by lowering the mute pin (pin 15) voltage below 0.5V.
- (3) All four driver output channels are muted during thermal shutdown, muting and a drop in bias pin voltage. No other components are muted.

●Electrical characteristics curves

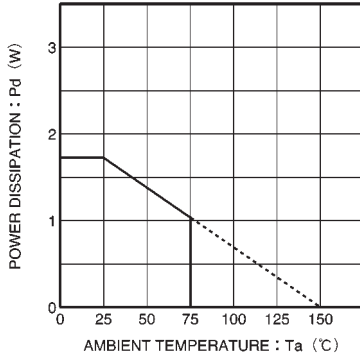

Fig. 6 Thermal derating curve

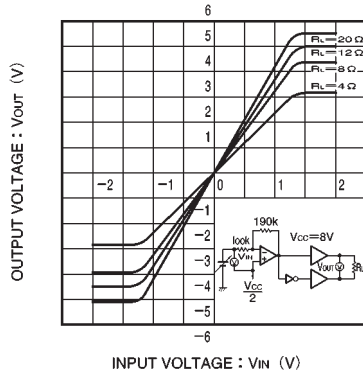

Fig. 7 Spindle driver (CH4) I/O characteristics (load variation)

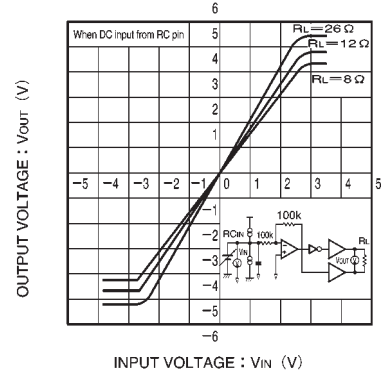

Fig. 8 I/O characteristics of driver stages CH1-CH3

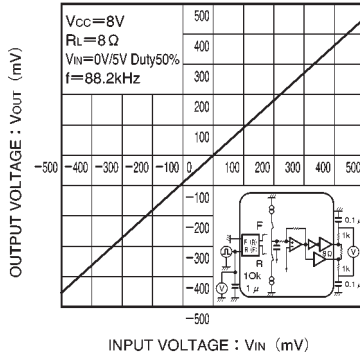

Fig. 9 I/O characteristics with pulse input (drivers CH1-CH3)

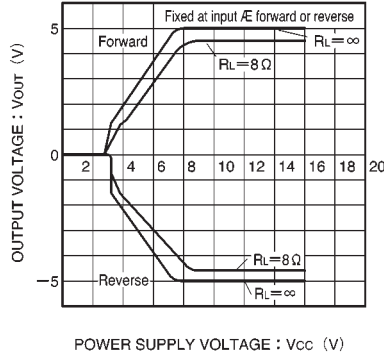

Fig. 10 Driver CH1-CH3 power supply voltage vs. output voltage

● External dimensions (Units: mm)

