

DATA SHEET

TDA6103Q

Triple video output amplifier

Preliminary specification
File under Integrated Circuits, IC02

March 1994

Philips Semiconductors



PHILIPS

Triple video output amplifier

TDA6103Q

FEATURES

- High bandwidth: 7.5 MHz typical; 60 V (peak-to-peak value)
- High slew rate: 1600 V/ μ s
- Simple application with a variety of colour decoders
- Only one supply voltage needed
- Internal protection against positive appearing Cathode-Ray Tube (CRT) flashover discharges
- One non-inverting input with a low minimum input voltage of 1 V
- Thermal protection
- Controllable switch-off behaviour.

GENERAL DESCRIPTION

The TDA6103Q includes three video output amplifiers in one single in-line 9-pin medium power (SIL9MP) package SOT111BE, using high-voltage DMOS technology, intended to drive the three cathodes of a colour CRT.

ORDERING INFORMATION

EXTENDED TYPE NUMBER	PACKAGE			
	PINS	PIN POSITION	MATERIAL	CODE
TDA6103Q	9	DBS9	plastic	SOT111BE

BLOCK DIAGRAM

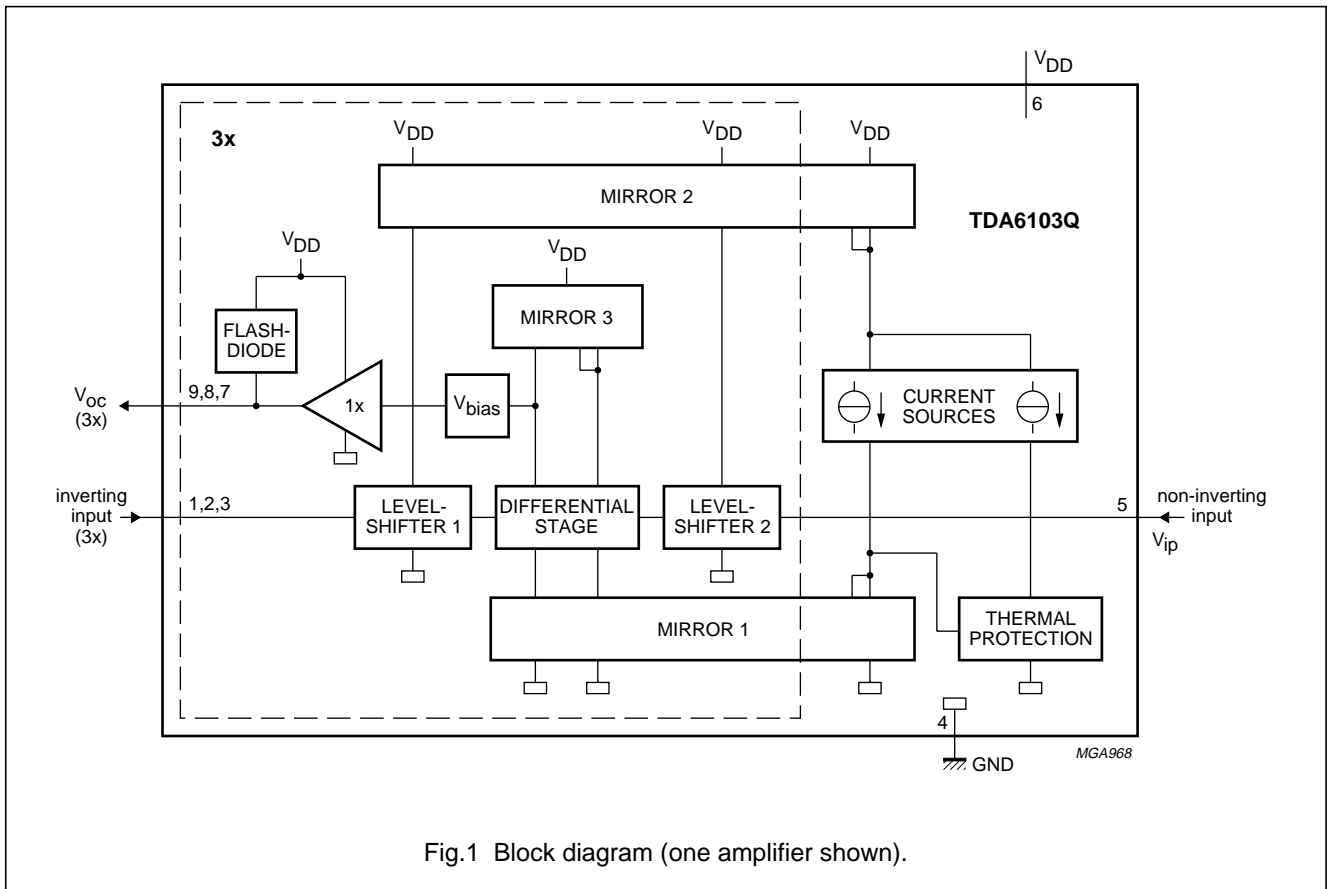

Triple video output amplifier

TDA6103Q

PINNING

SYMBOL	PIN	DESCRIPTION
V_{i1}	1	inverting input 1
V_{i2}	2	inverting input 2
V_{i3}	3	inverting input 3
GND	4	ground, fin
V_{ip}	5	non-inverting input
V_{DD}	6	supply voltage
V_{oc3}	7	cathode output 3
V_{oc2}	8	cathode output 2
V_{oc1}	9	cathode output 1

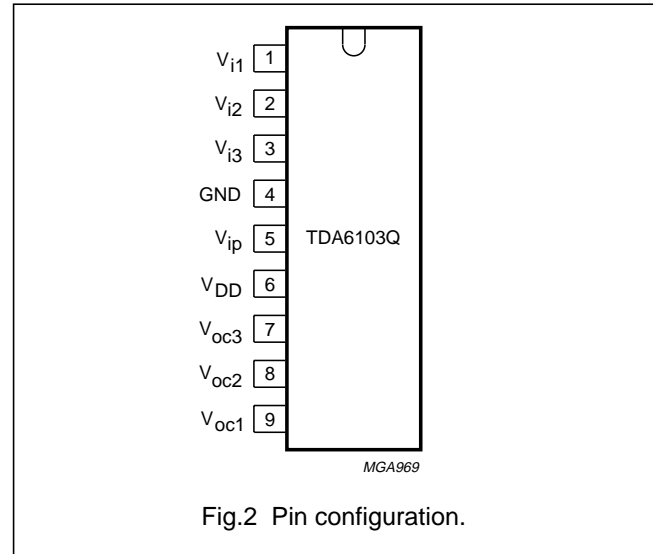

LIMITING VALUES

In accordance with the Absolute Maximum Rating System (IEC 134). Voltages measured with respect to GND (pin 4); currents as specified in Fig.1; unless otherwise specified.

SYMBOL	PARAMETER	CONDITIONS	MIN.	MAX.	UNIT
V_{DD}	supply voltage		0	250	V
V_i	input voltage		0	12	V
V_{idm}	differential mode input voltage		-6	+6	V
V_{oc}	cathode output voltage		0	V_{DD}	V
I_{ocsmL}	LOW non-repetitive peak cathode output current	flashover discharge = 50 μ C	0	5	A
I_{ocsmH}	HIGH non-repetitive peak cathode output current	flashover discharge = 100 nC	0	10	A
T_{stg}	storage temperature		-55	+150	$^{\circ}$ C
T_j	junction temperature		-20	+150	$^{\circ}$ C
V_{es}	electrostatic handling				
	human body model (HBM)		-	tbf	V
	machine model (MM)		-	tbf	V

HANDLING

Inputs and outputs are protected against electrostatic discharge in normal handling. However, to be totally safe, it is desirable to take normal precautions appropriate to handling MOS devices (see "Handling MOS Devices").

QUALITY SPECIFICATION

Quality specification "SNW-FQ-611 part E" is applicable and can be found in the "Quality reference pocketbook" (ordering number 9398 510 34011).

Triple video output amplifier

TDA6103Q

THERMAL RESISTANCE

SYMBOL	PARAMETER	THERMAL RESISTANCE
$R_{th\ j-fin}$	from junction to fin; note 1	11 K/W
$R_{th\ h-a}$	from heatsink to ambient	18 K/W

Note

1. An external heatsink is necessary.

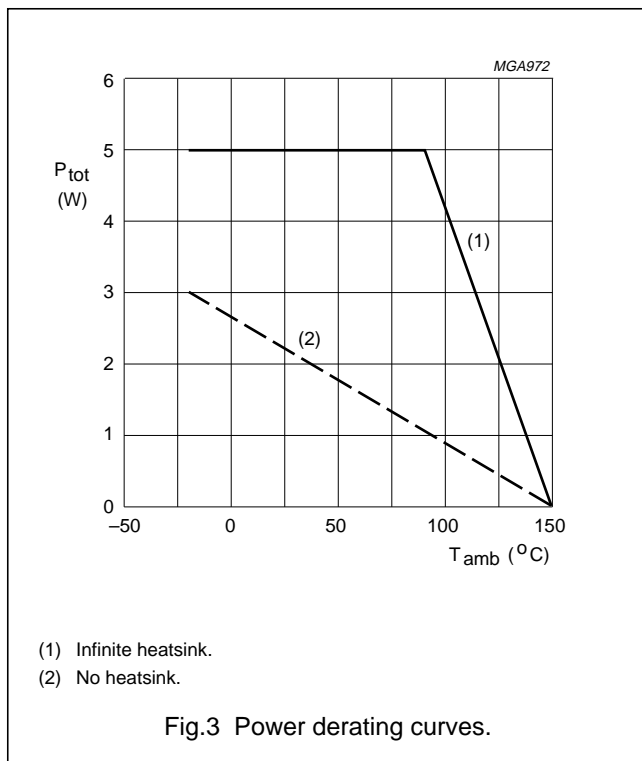

Thermal protection

The internal thermal protection circuit gives a decrease of the slew rate at high temperatures: 10% decrease at 130 $^{\circ}C$ and 30% decrease at 145 $^{\circ}C$ (typical values on the spot of the thermal protection circuit).

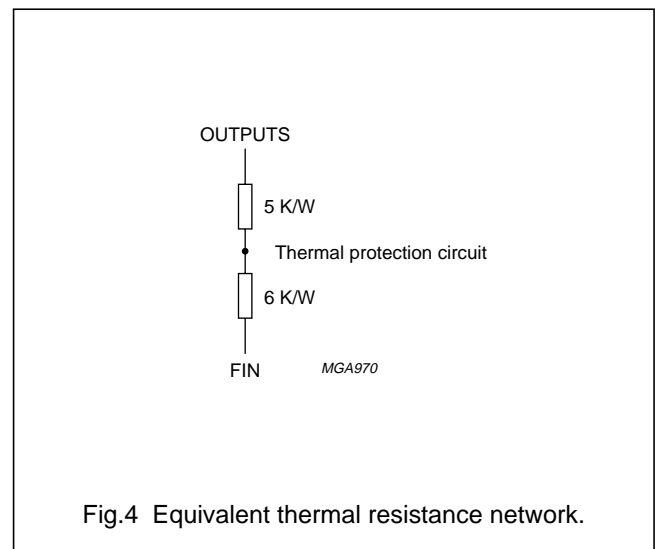

Triple video output amplifier

TDA6103Q

CHARACTERISTICS

Operating range: $T_j = -20$ to 150 °C; $V_{DD} = 180$ to 210 V; $V_{ip} = 1$ to 4 V.

Test conditions (unless otherwise specified): $T_{amb} = 25$ °C; $V_{DD} = 200$ V; $V_{ip} = 1.3$ V; $V_{oc1} = V_{oc2} = V_{oc3} = \frac{1}{2}V_{DD}$;

$C_L = 10$ pF (C_L consists of parasitic and cathode capacitance); $R_{th\ h-a} = 18$ K/W; measured in test circuit Fig.5.

SYMBOL	PARAMETER	CONDITIONS	MIN.	TYP.	MAX.	UNIT
I_{DD}	quiescent supply current		7.0	9.25	11.5	mA
I_{bias}	input bias current inverting inputs (pins 1, 2 and 3)		-5	-1	+1	μ A
I_{bias}	input bias current non-inverting input (pin 5)		-15	-3	+1	μ A
$V_{i(\text{offset})}$	input offset voltage (pins 1, 2 and 3)		-50	-	+50	mV
$\Delta V_{i(\text{offset})}$	differential input offset voltage temperature drift between pins 1 and 5; 2 and 5; 3 and 5		-	tbf	-	mV/K
C_{icm}	common-mode input capacitance (pins 1, 2 and 3)		-	5	-	pF
C_{icm}	common-mode input capacitance (pin 5)		-	10	-	pF
C_{idm}	differential mode input capacitance between 1 and 5; 2 and 5; 3 and 5		-	1	-	pF
$V_{oc(\text{min})}$	minimum output voltage (pins 7, 8 and 9)	$V_{1-5} = V_{2-5} = V_{3-5} = -1$ V	-	5	10	V
$V_{oc(\text{max})}$	maximum output voltage (pins 7, 8 and 9)	$V_{1-5} = V_{2-5} = V_{3-5} = 1$ V; note 1	$V_{DD} - 10$	$V_{DD} - 6$	-	V
GB	gain-bandwidth product of open-loop gain: $V_{oc1, 2, 3} / V_{i1-5, 2-5, 3-5}$	$f = 500$ kHz	-	0.75	-	GHz
B_S	small signal bandwidth (pins 7, 8 and 9)	$V_{oc(p-p)} = 60$ V	6	7.5	-	MHz
B_L	large signal bandwidth (pins 7, 8 and 9)	$V_{oc(p-p)} = 100$ V	5	7	-	MHz
t_{pd}	cathode output propagation delay time 50% input to 50% output (pins 7, 8 and 9)	$V_{oc(p-p)} = 100$ V square wave; $f < 1$ MHz; $t_r = t_f = 40$ ns (pins 1, 2 and 3); see Figs 7 and 8	-	38	-	ns
Δt_p	difference in cathode output propagation time 50% input to 50% output (pins 7 and 8, 7 and 9 and 8 and 9)	$V_{oc(p-p)} = 100$ V square wave; $f < 1$ MHz; $t_r = t_f = 40$ ns (pins 1, 2 and 3)	-10	0	+10	ns
t_r	cathode output rise time 10% output to 90% output (pins 7, 8 and 9)	$V_{oc} = 50$ to 150 V square wave; $f < 1$ MHz; $t_f = 40$ ns (pins 1, 2 and 3); see Fig.7	48	60	73	ns
t_f	cathode output fall time 90% output to 10% output (pins 7, 8 and 9)	$V_{oc} = 150$ to 50 V square wave; $f < 1$ MHz; $t_r = 40$ ns (pins 1, 2 and 3); see Fig.8	48	60	73	ns

Triple video output amplifier

TDA6103Q

SYMBOL	PARAMETER	CONDITIONS	MIN.	TYP.	MAX.	UNIT
t_s	settling time 50% input to (99% < output < 101%)	$V_{oc(p-p)} = 100$ V square wave; $f < 1$ MHz; $t_r = t_f = 40$ ns (pins 1, 2 and 3); see Figs 7 and 8	–	–	350	ns
SR	slew rate between 50 V to ($V_{DD} - 50$ V); (pins 7, 8 and 9)	$V_{1-5} = V_{2-5} = V_{3-5} = 2$ V square wave (p-p); $f < 1$ MHz; $t_r = t_f = 40$ ns (pins 1, 2 and 3)	–	1600	–	V/ μ s
O_v	cathode output voltage overshoot (pins 7, 8 and 9)	$V_{oc(p-p)} = 100$ V square wave; $f < 1$ MHz; $t_r = t_f = 40$ ns (pins 1, 2 and 3); see Figs 7 and 8	–	5	–	%
SVRR	supply voltage rejection ratio	$f < 50$ kHz; note 2	–	70	–	dB

Notes

- See also Fig.6 for the typical low-frequency response of V_i to V_{oc} .
- The ratio of the change in supply voltage to the change in input voltage when there is no change in output voltage.

Cathode output

The cathode output is protected against peak currents (caused by positive voltage peaks during high-resistance flash) of 5 A maximum with a charge content of 50 μ C.

The cathode is also protected against peak currents (caused by positive voltage peaks during low-resistance flash) of 10 A maximum with a charge content of 100 nC.

The DC voltage of V_{DD} (pin 6) must be within the operating range of 180 to 210 V during the peak currents.

Flashover protection

The TDA6103Q incorporates protection diodes against CRT flashover discharges that clamp the cathode output voltage up to a maximum of $V_{DD} + V_{diode}$. To limit the diode current, an external 1.5 k Ω carbon high-voltage resistor in series with the cathode output and a 2 kV spark gap are

needed (for this resistor-value, the CRT has to be connected to the main PCB). This addition produces an increase in the rise- and fall times of approximately 5 ns and a decrease in the overshoot of approximately 3%.

V_{DD} to GND must be decoupled:

- With a capacitor >20 nF with good HF behaviour (e.g. foil). This capacitance must be placed as close as possible to pins 6 and 4, but definitely within 5 mm.
- With a capacitor >10 μ F on the picture tube base print.

Switch-off behaviour

The switch-off behaviour of the TDA6103Q is controllable. This is due to the fact that the output pins of the TDA6103Q are still under control of the input pins for relative low-power supply voltages (approximately 30 V and higher).

Triple video output amplifier

TDA6103Q

Test circuit

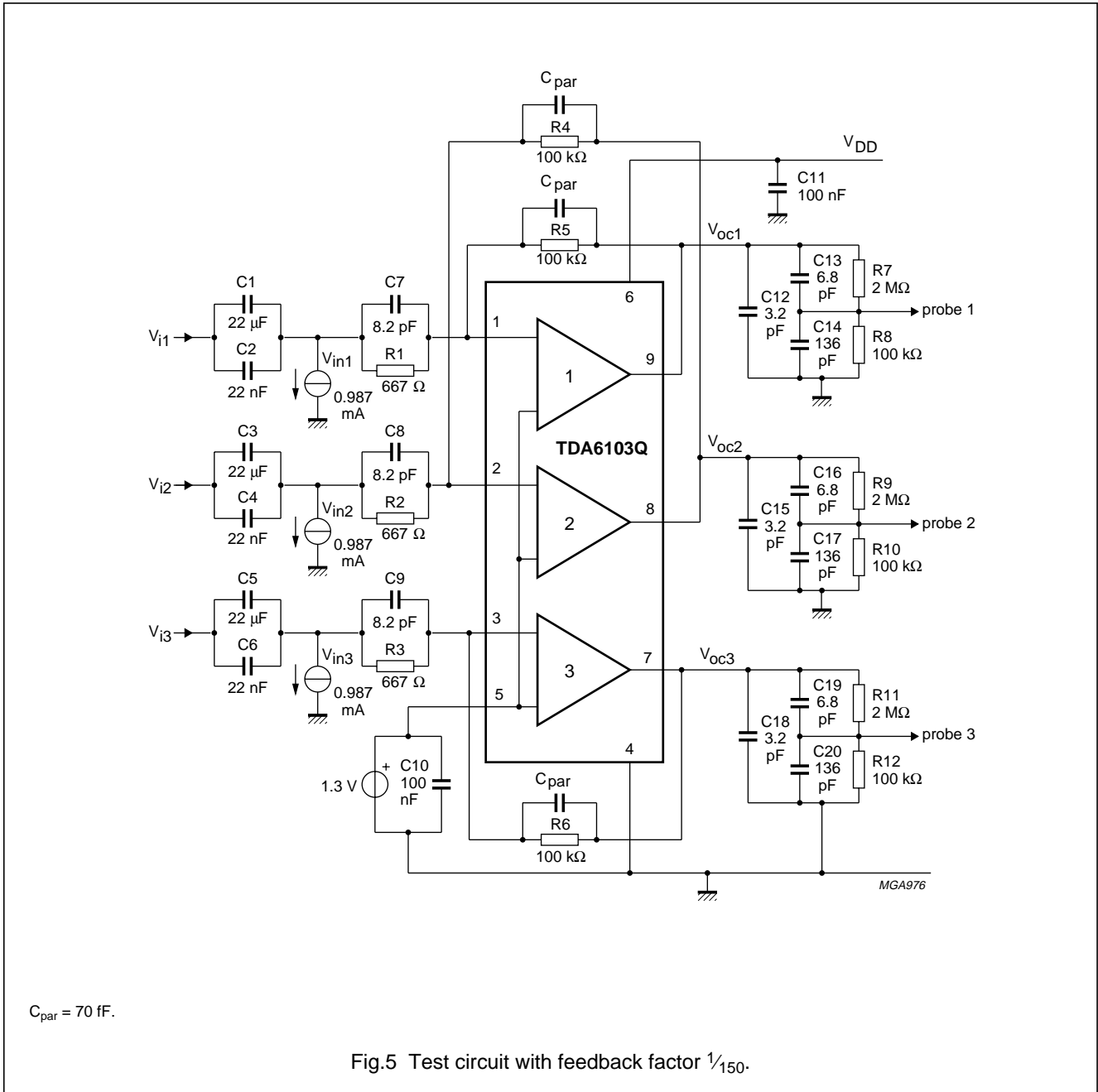

Triple video output amplifier

TDA6103Q

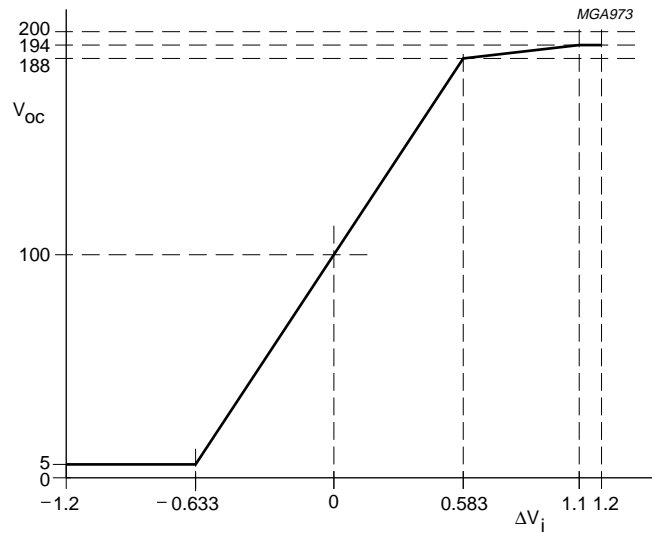

Fig.6 Typical low-frequency ($f < 1$ MHz) response of $\Delta V_{i1, 2, 3}$ to $V_{oc1, 2, 3}$.

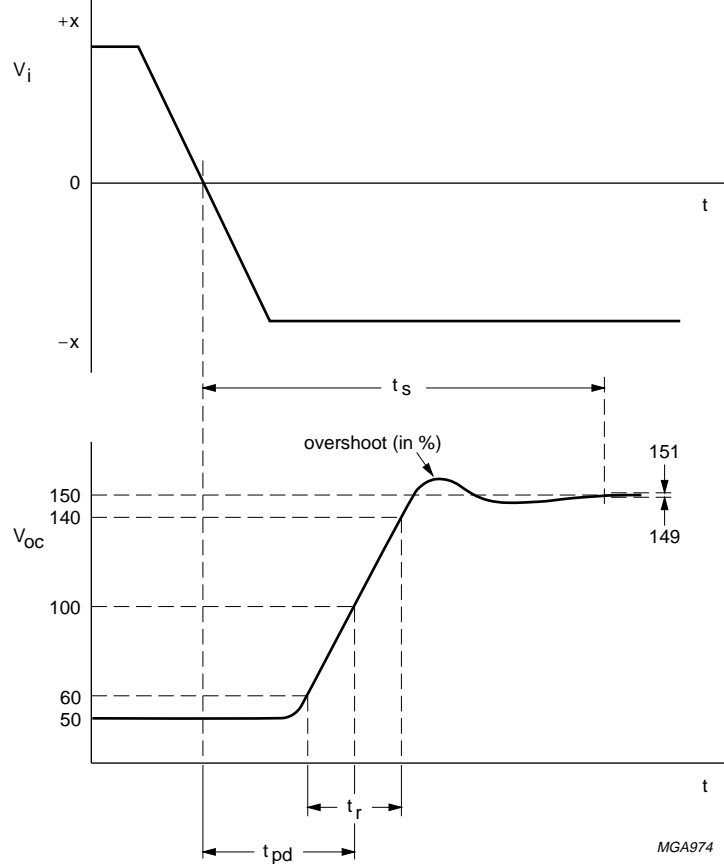

Fig.7 Output voltage (pins 7, 8 and 9) rising edge as a function of the AC input signal.

Triple video output amplifier

TDA6103Q

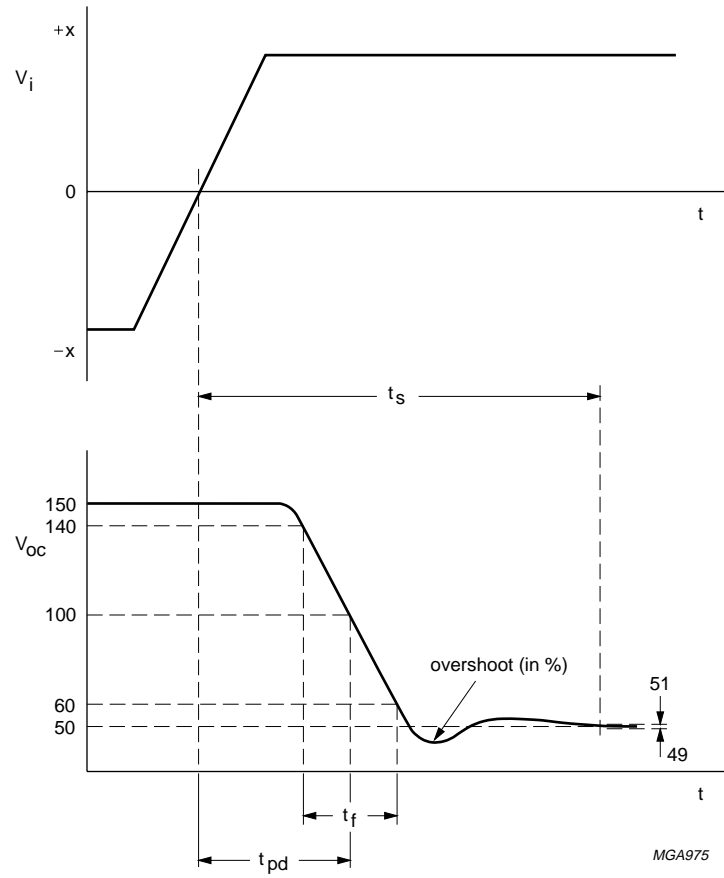
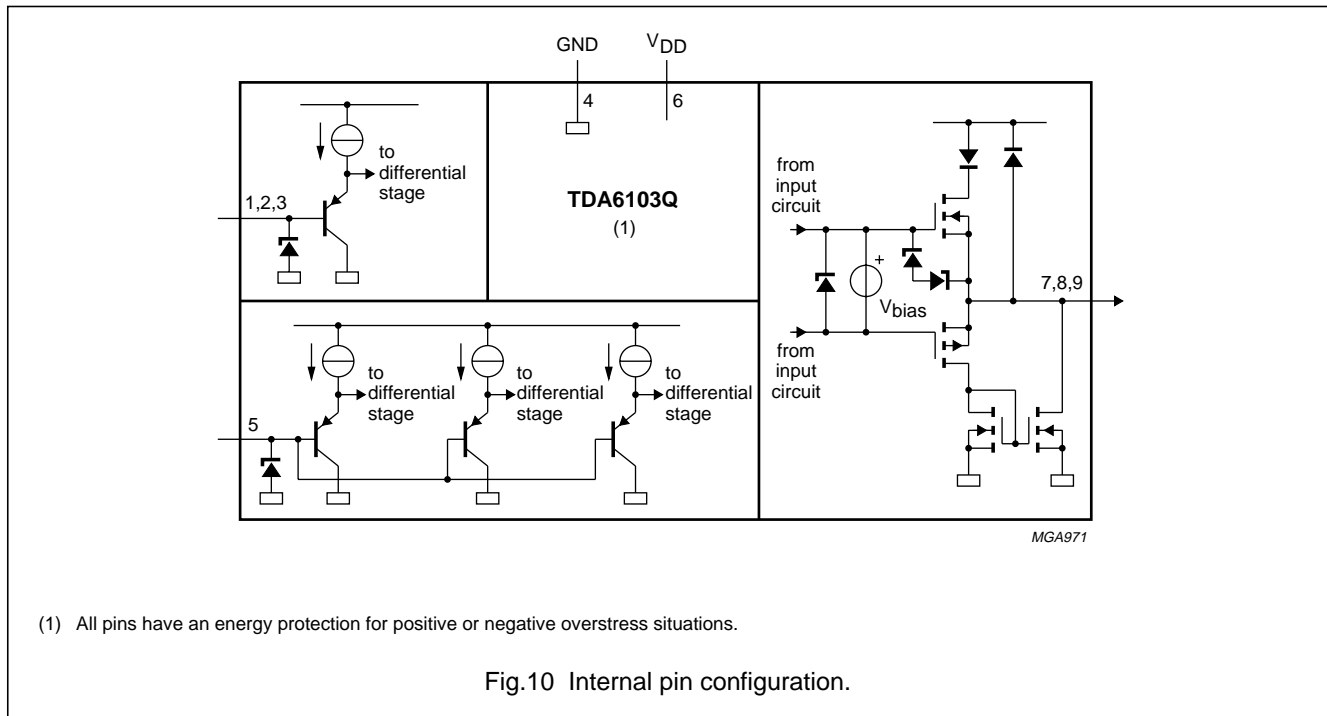

Fig.8 Output voltage (pins 7, 8 and 9) falling edge as a function of the AC input signal.

Triple video output amplifier

TDA6103Q

**Dissipation**

Regarding dissipation, distinction must first be made between static dissipation (independent of frequency) and dynamic dissipation (proportional to frequency).

The static dissipation of the TDA6103Q is due to voltage supply currents and load currents in the feedback network and CRT.

The static dissipation equals:

$$P_{\text{stat}} = V_{\text{DD}} \times I_{\text{DD}} - 3 \times V_{\text{oc}} \times (V_{\text{oc}}/R_{\text{fb}} - I_{\text{OC}})$$

R_{fb} = value of feedback resistor.

I_{OC} = DC-value of cathode current.

The dynamic dissipation equals:

$$P_{\text{dyn}} = 3 \times V_{\text{DD}} \times (C_{\text{L}} + C_{\text{fb}} + C_{\text{int}}) \times f_{\text{i}} \times V_{\text{o(p-p)}} \times \delta$$

C_{L} = load capacitance.

C_{fb} = feedback capacitance.

C_{int} = internal load capacitance (≈ 4 pF).

f_{i} = input frequency.

$V_{\text{o(p-p)}}$ = output voltage (peak-to-peak value).

δ = non-blanking duty-cycle.

The IC must be mounted on the picture tube base print to minimize the load capacitance (C_{L}).

Triple video output amplifier

TDA6103Q

PACKAGE OUTLINE

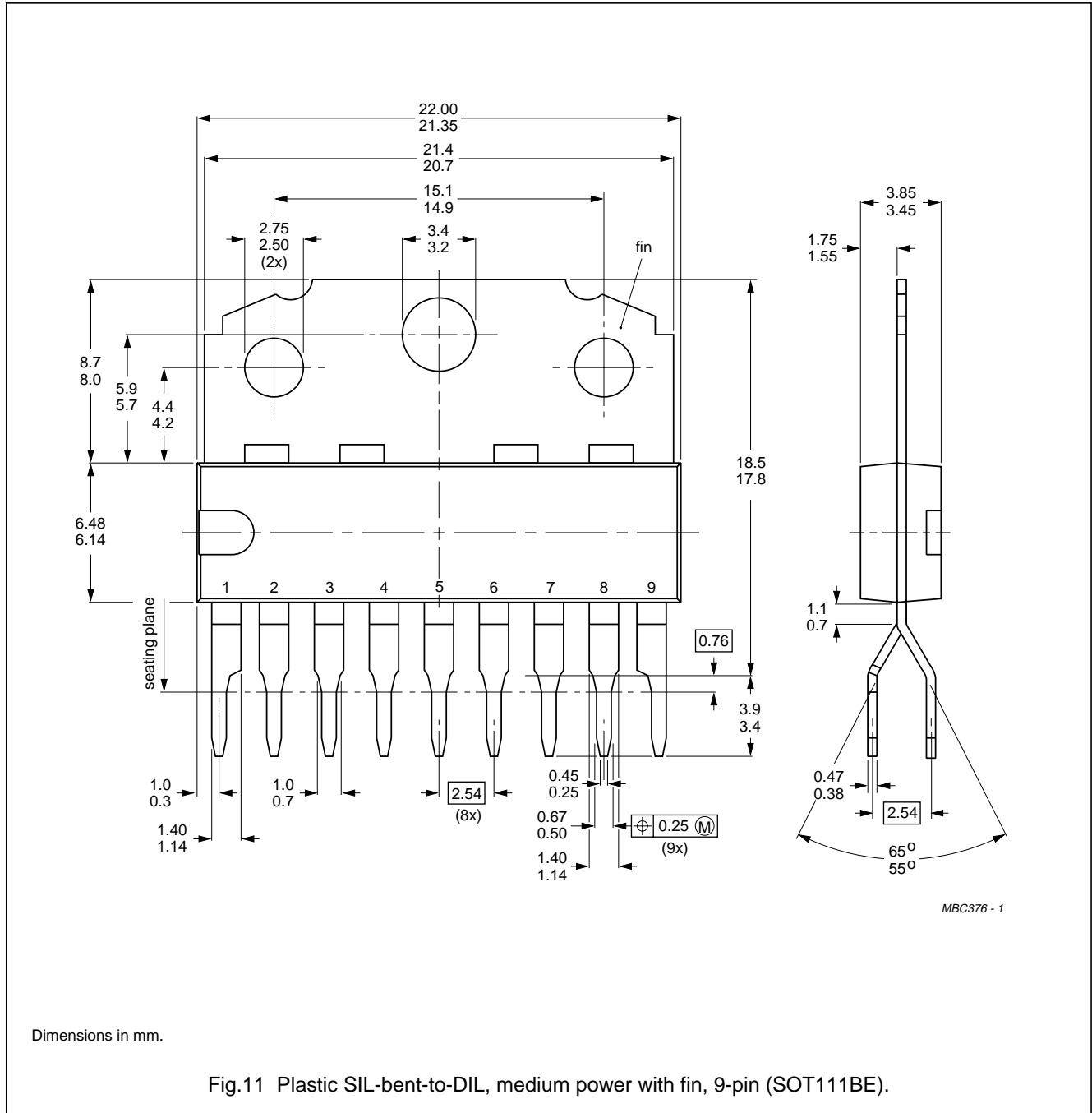

Triple video output amplifier

TDA6103Q

SOLDERING**Plastic single in-line packages**

BY DIP OR WAVE

The maximum permissible temperature of the solder is 260 °C; this temperature must not be in contact with the joint for more than 5 s. The total contact time of successive solder waves must not exceed 5 s.

The device may be mounted up to the seating plane, but the temperature of the plastic body must not exceed the specified storage maximum. If the printed-circuit board has been pre-heated, forced cooling may be necessary immediately after soldering to keep the temperature within the permissible limit.

REPAIRING SOLDERED JOINTS

Apply the soldering iron below the seating plane (or not more than 2 mm above it). If its temperature is below 300 °C, it must not be in contact for more than 10 s; if between 300 and 400 °C, for not more than 5 s.

DEFINITIONS

Data sheet status	
Objective specification	This data sheet contains target or goal specifications for product development.
Preliminary specification	This data sheet contains preliminary data; supplementary data may be published later.
Product specification	This data sheet contains final product specifications.
Limiting values	
Limiting values given are in accordance with the Absolute Maximum Rating System (IEC 134). Stress above one or more of the limiting values may cause permanent damage to the device. These are stress ratings only and operation of the device at these or at any other conditions above those given in the Characteristics sections of the specification is not implied. Exposure to limiting values for extended periods may affect device reliability.	
Application information	
Where application information is given, it is advisory and does not form part of the specification.	

LIFE SUPPORT APPLICATIONS

These products are not designed for use in life support appliances, devices, or systems where malfunction of these products can reasonably be expected to result in personal injury. Philips customers using or selling these products for use in such applications do so at their own risk and agree to fully indemnify Philips for any damages resulting from such improper use or sale.

Triple video output amplifier

TDA6103Q

NOTES

Triple video output amplifier

TDA6103Q

NOTES

Philips Semiconductors – a worldwide company

Argentina: IEROD, Av. Juramento 1992 - 14.b, (1428)
BUENOS AIRES, Tel. (541)786 7633, Fax. (541)786 9367

Australia: 34 Waterloo Road, NORTH RYDE, NSW 2113,
Tel. (02)805 4455, Fax. (02)805 4466

Austria: Triester Str. 64, A-1101 WIEN, P.O. Box 213,
Tel. (01)60 101-1236, Fax. (01)60 101-1211

Belgium: Postbus 90050, 5600 PB EINDHOVEN, The Netherlands,
Tel. (31)40 783 749, Fax. (31)40 788 399

Brazil: Rua do Rocio 220 - 5th floor, Suite 51,
CEP: 04552-903-SÃO PAULO-SP, Brazil.
P.O. Box 7383 (01064-970).

Tel. (011)829-1166, Fax. (011)829-1849

Canada: INTEGRATED CIRCUITS:

Tel. (800)234-7381, Fax. (708)296-8556

DISCRETE SEMICONDUCTORS: 601 Milner Ave,
SCARBOROUGH, ONTARIO, M1B 1M8,
Tel. (416)292 5161 ext. 2336, Fax. (416)292 4477

Chile: Av. Santa Maria 0760, SANTIAGO,
Tel. (02)773 816, Fax. (02)777 6730

Colombia: Carrera 21 No. 56-17, BOGOTÁ, D.E., P.O. Box 77621,
Tel. (571)217 4609, Fax. (01)217 4549

Denmark: Prags Boulevard 80, PB 1919, DK-2300 COPENHAGEN S,
Tel. (032)88 2636, Fax. (031)57 1949

Finland: Sinikalliontie 3, FIN-02630 ESPOO,
Tel. (9)0-50261, Fax. (9)0-520971

France: 4 Rue du Port-aux-Vins, BP317,
92156 SURESNES Cedex,
Tel. (01)4099 6161, Fax. (01)4099 6427

Germany: P.O. Box 10 63 23, 20095 HAMBURG ,
Tel. (040)3296-0, Fax. (040)3296 213

Greece: No. 15, 25th March Street, GR 17778 TAVROS,
Tel. (01)4894 339/4894 911, Fax. (01)4814 240

Hong Kong: 15/F Philips Ind. Bldg., 24-28 Kung Yip St.,
KWAI CHUNG, Tel. (0)4245 121, Fax. (0)4806 960

India: PHILIPS ELECTRONICS & ELECTRICALS Ltd.,
Components Dept., Shivsagar Estate, Block 'A',
Dr. Annie Besant Rd., Worli, BOMBAY 400 018,
Tel. (022)4938 541, Fax. (022)4938 722

Indonesia: Philips House, Jalan H.R. Rasuna Said Kav. 3-4,
P.O. Box 4252, JAKARTA 12950,
Tel. (021)5201 122, Fax. (021)5205 189

Ireland: Newstead, Clonskeagh, DUBLIN 14,
Tel. (01)640 000, Fax. (01)640 200

Italy: Viale F. Testi, 327, 20162 MILANO,
Tel. (02)6752.1, Fax. (02)6752.3350

Japan: Philips Bldg 13-37, Kohnan2-chome, Minato-ku, KOKIO 108,
Tel. (03)3740 5101, Fax. (03)3740 0570

Korea: (Republic of) Philips House, 260-199 Itaewon-dong,
Yongsan-ku, SEOUL, Tel. (02)794-5011, Fax. (02)798-8022

Malaysia: No. 76 Jalan Universiti, 46200 PETALING JAYA,
SELANGOR, Tel. (03)757 5511, Fax. (03)757 4880

Mexico: Philips Components, 5900 Gateway East, Suite 200,
EL PASO, TX 79905, Tel. 9-5(800)234-7381, Fax. (708)296-8556

Netherlands: Postbus 90050, 5600 PB EINDHOVEN,
Tel. (040)78 37 49, Fax. (040)78 83 99

New Zealand: 2 Wagener Place, C.P.O. Box 1041, AUCKLAND,
Tel. (09)849-4160, Fax. (09)849-7811

Norway: Box 1, Manglerud 0612, OSLO,
Tel. (22)74 8000, Fax. (22)74 8341

Pakistan: Philips Markaz, M.A. Jinnah Rd., KARACHI 3,
Tel. (021)577 039, Fax. (021)569 1832

Philippines: PHILIPS SEMICONDUCTORS PHILIPPINES Inc,
106 Valero St. Salcedo Village, P.O. Box 2108 MCC, MAKATI,
Metro MANILA, Tel. (02)810 0161, Fax. (02)817 3474

Portugal: Av. Eng. Duarte Pacheco 6, 1009 LISBOA Codex,
Tel. (01)683 121, Fax. (01)658 013

Singapore: Lorong 1, Toa Payoh, SINGAPORE 1231,
Tel. (65)350 2000, Fax. (65)251 6500

South Africa: 195-215 Main Road, Martindale,
P.O. Box 7430, JOHANNESBURG 2000,
Tel. (011)470-5433, Fax. (011)470-5494

Spain: Balmes 22, 08007 BARCELONA,
Tel. (03)301 6312, Fax. (03)301 42 43

Sweden: Kottbygatan 7, Akalla. S-164 85 STOCKHOLM,
Tel. (0)8-632 2000, Fax. (0)8-632 2745

Switzerland: Allmendstrasse 140, CH-8027 ZÜRICH,
Tel. (01)488 2211, Fax. (01)481 7730

Taiwan: 23-30F, 66, Chung Hsiao West Road, Sec. 1, P.O. Box
22978, TAIPEI 10446, Tel. (2)388 7666, Fax. (2)382 4382

Thailand: PHILIPS ELECTRONICS (THAILAND) Ltd.,
60/14 MOO 11, Bangna - Trad Road Km. 3
Prakanong, BANGKOK 10260,

Tel. (2)399-3280 to 9, (2)398-2083, Fax. (2)398-2080

Turkey: Talatpasa Cad. No. 5, 80640 LEVENT/ISTANBUL,
Tel. (0212)279 2770, Fax. (0212)269 3094

United Kingdom: Philips Semiconductors Limited, P.O. Box 65,
Philips House, Torrington Place, LONDON, WC1E 7HD,
Tel. (071)436 41 44, Fax. (071)323 03 42

United States: INTEGRATED CIRCUITS:

811 East Arques Avenue, SUNNYVALE, CA 94088-3409,

Tel. (800)234-7381, Fax. (708)296-8556

DISCRETE SEMICONDUCTORS: 2001 West Blue Heron Blvd.,
P.O. Box 10330, RIVIERA BEACH, FLORIDA 33404,
Tel. (800)447-3762 and (407)881-3200, Fax. (407)881-3300

Uruguay: Coronel Mora 433, MONTEVIDEO,
Tel. (02)70-4044, Fax. (02)92 0601

For all other countries apply to: Philips Semiconductors,
International Marketing and Sales, Building BAF-1,
P.O. Box 218, 5600 MD, EINDHOVEN, The Netherlands,
Telex 35000 phicnl, Fax. +31-40-724825

SCD29

© Philips Electronics N.V. 1994

All rights are reserved. Reproduction in whole or in part is prohibited without the prior written consent of the copyright owner.

The information presented in this document does not form part of any quotation or contract, is believed to be accurate and reliable and may be changed without notice. No liability will be accepted by the publisher for any consequence of its use. Publication thereof does not convey nor imply any license under patent- or other industrial or intellectual property rights.

Printed in The Netherlands

9397 730 00011

Philips Semiconductors



PHILIPS