

DATA SHEET

TDA3845; TDA3845T Quasi split-sound circuit and AM demodulator

Objective specification
File under Integrated Circuits, IC02

January 1993

Quasi split-sound circuit and AM demodulator

TDA3845; TDA3845T

FEATURES

- Power supply from 5 V (200 mW) to 8 V source also an alternative 12 V source (12 V not for TDA3845T)
- Gain controlled wideband IF amplifier (AC coupled with three stages)
- High precision internal 90° phase shifter for quadrature demodulator
- Amplitude detector for gain control which operates as a peak detector for FM sound and as a mean level detector for AM sound (switchable)
- In-phase wideband synchronous demodulator for AM detection

- Stabilizer circuit for ripple rejection and constant output signals
- ESD protection for all pins
- Suitable for all FM standards and L as well as L-accent standard
- NICAM compatible.

GENERAL DESCRIPTION

The TDA3845 is a quasi split-sound IF circuit which is designed to provide high performance television FM/AM sound.

QUICK REFERENCE DATA

SYMBOL	PARAMETER	MIN.	TYP.	MAX.	UNIT
V _{P1}	positive supply voltage pin 14	4.5	5.0	8.8	V
V _{P2}	pin 11 (not for TDA3845T)	10.8	12.0	13.2	V
I _P	supply current	–	40	–	mA
V _{1-16(RMS)}	minimum IF input voltage (RMS value)	–	70	100	μV
	IF control range	60	63	–	dB
V _{12-13(RMS)}	intercarrier output voltage 5.5 MHz (RMS value)	70	100	–	mV
(S + W)/W	signal-to-weighted-noise ratio (relative to 1 kHz; 50 kHz deviation)				
	at 5.5 MHz for 2T/20T	–	60	–	dB
	at 5.742 MHz for 2T/20T	–	58	–	dB
V _{6-13(RMS)}	AF output voltage AM (RMS value)	440	550	660	mV
(S + W)/W	signal-to-weighted-noise ratio; AM mode	–	56	–	dB
THD	total harmonic distortion; AM mode	–	1	2	%
T _{amb}	operating ambient temperature	0	–	+70	°C

ORDERING INFORMATION

EXTENDED TYPE NUMBER	PACKAGE			
	PINS	PIN POSITION	MATERIAL	CODE
TDA3845	16	DIL	plastic	SOT38 ⁽¹⁾
TDA3845T	16	SO16	plastic	SOT109A ⁽²⁾

Note

1. SOT38-1; 1996 November 28.
2. SOT109-1; 1996 November 28.

Quasi split-sound circuit and AM demodulator

TDA3845; TDA3845T

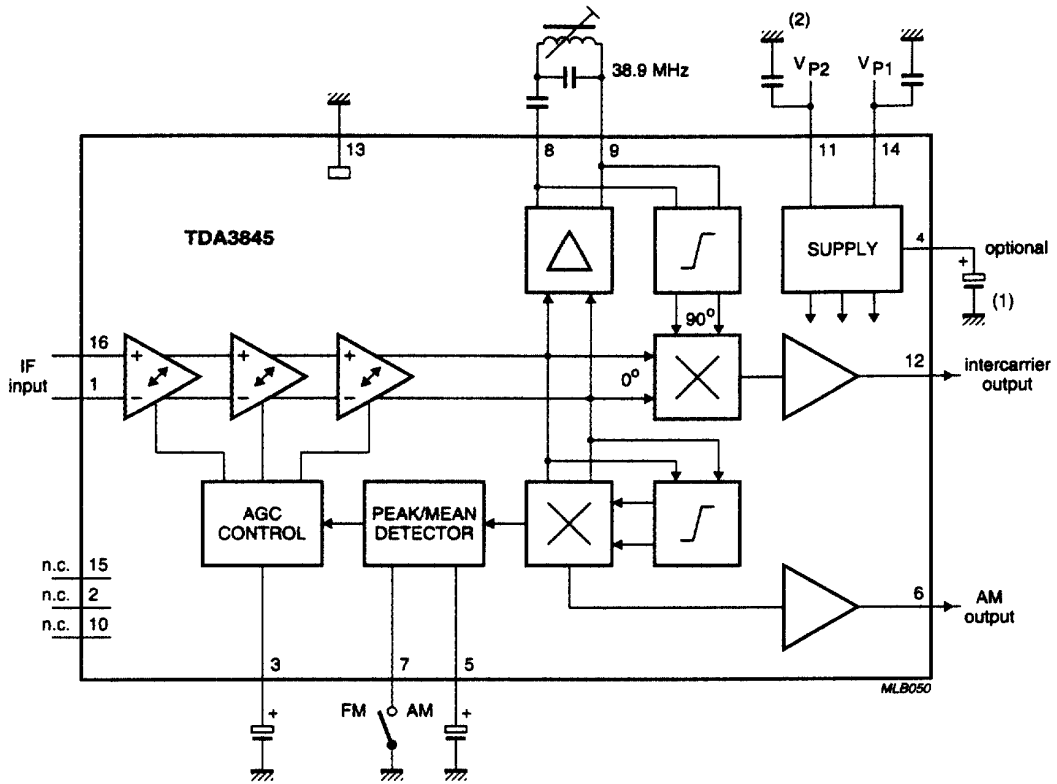

- (1) See note 10 to the characteristics.
- (2) Not for TDA3845T, pin 11 not connected.

Fig.1 Block diagram.

Quasi split-sound circuit and AM demodulator

TDA3845; TDA3845T

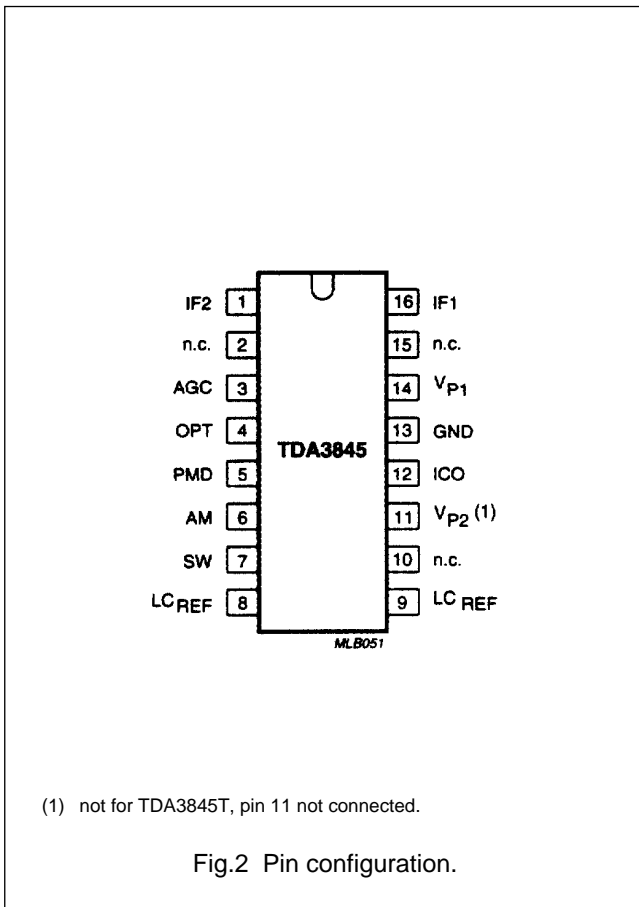

PINNING

SYMBOL	PIN	DESCRIPTION
IF2	1	IF amplifier input 2
n.c.	2	not connected
AGC	3	AGC control capacitor
OPT	4	optional capacitor (see note 10 to the characteristics)
PMD	5	peak/mean detector capacitor
AM	6	AM output
SW	7	FM/AM switch
LC _{REF}	8	LC reference circuit for the picture carrier
LC _{REF}	9	LC reference circuit for the picture carrier
n.c.	10	not connected
V _{P2}	11	positive supply voltage 2 (+12 V); note 1
ICO	12	intercarrier output
GND	13	ground (0 V)
V _{P1}	14	positive supply voltage 1 (+5 V)
n.c.	15	not connected
IF1	16	IF amplifier input 1

Note to Pinning

1. Not for TDA3845T, pin 11 not connected.

LIMITING VALUES

In accordance with the Absolute Maximum Rating System (IEC134)

SYMBOL	PARAMETER	MIN.	MAX.	UNIT
V _{P1}	supply voltage pin 14	4.5	8.8	V
V _{P2}	pin 11 (not for TDA3845T)	10.8	13.2	V
T _{amb}	operating ambient temperature	0	+70	°C
T _{stg}	storage temperature	-25	+125	°C

Quasi split-sound circuit and AM demodulator

TDA3845; TDA3845T

CHARACTERISTICS

$V_{P1} = 5\text{ V}$ (note 11); $T_{amb} = 25\text{ °C}$; all measurements are referenced to ground (pin 13); unless otherwise specified.

SYMBOL	PARAMETER	CONDITIONS	MIN.	TYP.	MAX.	UNIT
Supply						
V_{P1}	supply voltage pin 14		4.5	5.0	8.8	V
V_{P2}	pin 11 (not for TDA3845T)		10.8	12.0	13.2	V
I_{tot}	total supply current		–	40	48	mA
IF amplifier						
R_{1-16}	input resistance		–	2	–	k Ω
C_{1-16}	input capacitance		–	2.5	–	pF
$V_{1-16(RMS)}$	minimum IF input voltage (RMS value)	note 1	–	70	100	μ V
$V_{1-16(RMS)}$	maximum IF input voltage (RMS value)	note 2	70	100	–	mV
ΔG	gain control range		60	63	–	dB
G_{v3-16}	gain control voltage range		1.5	–	3.0	V
B_{IF}	IF bandwidth	–3 dB	50	70	–	MHz
V_{1-16}	DC potential		–	1.7	–	V
Intercarrier mode (FM mode; standard B/G) notes 3, 4 and 5						
Reference amplifier						
$V_{8-9(p-p)}$	picture carrier amplitude (peak-to-peak value)		–	270	–	mV
R_{8-9}	operating resistance		–	4	–	k Ω
V_{8-9}	DC potential		–	3.9	–	V
Intercarrier mixer and output stage						
$V_{12(RMS)}$	output signal (RMS value) at 5.5 MHz at 5.74 MHz		70	100	–	mV
			32	45	–	mV
B_{12}	intercarrier bandwidth at –1 dB at –3 dB		–	8	–	MHz
			–	9	–	MHz
	residual video AM on intercarrier signal	note 6	–	3	10	%
R_{12}	output resistance		–	30	–	Ω
V_{12}	DC potential		–	1.8	–	V
$I_{12(peak)}$	permissible AC output current (peak value)	note 7	–	–	± 0.7	mA
I_{12}	permissible DC output current		–	–	–2	mA

Quasi split-sound circuit and AM demodulator

TDA3845; TDA3845T

SYMBOL	PARAMETER	CONDITIONS	MIN.	TYP.	MAX.	UNIT
AF signal performance (note 8)						
(S +W)/W	black picture		60/58	68/64	–	dB
(S +W)/W	2T/20T pulses with white bars		57/55	60/58	–	dB
(S +W)/W	6 kHz sinewave (black-to-white modulation)		53/51	57/55	–	dB
(S +W)/W	250 kHz square wave (black-to-white modulation)		50/44	56/50	–	dB
AM mode (standard L) note 9						
S/N weighted in accordance with CCIR 468-3						
$V_{6(RMS)}$	AF output signal (RMS value)		440	550	660	mV
B_{AF}	AF bandwidth	–3 dB; note 12	0.02	–	120	kHz
THD	total harmonic distortion		–	1	2	%
(S +W)/W	signal-to-weighted-noise ratio	note 10	50	56	–	dB
R_6	output resistance		–	200	–	Ω
V_6	DC potential		–	1.8	–	V
$I_{6(peak)}$	permissible AC output current (peak value)	note 7	–	–	± 0.3	mA
I_6	permissible DC output current		–	–	–1	mA
Standard switch (note 4)						
V_7	peak signal AGC (FM mode)	V_{P1} used	1.8	–	V_{P1}	V
V_7	or switch open-circuit	V_{P2} used	1.8	–	5.5	V
V_7	mean signal AGC (AM mode)		–	–	0.8	V
I_7	switch current					
	at 0 V		–	–	–200	μA
	at V_{P1}		–	–	10	μA
	at V_{P2}	via a 2.2 k Ω series resistor	–	–	2.5	mA
Ripple rejection (note 13)						
AM/AF signal						
α_{RR}	voltage ripple on V_P / voltage ripple on output signal		30	40	–	dB
FM phase noise						
$\Delta f(RMS)$	intercarrier signal		–	10	20	Hz

Quasi split-sound circuit and AM demodulator

TDA3845; TDA3845T

SYMBOL	PARAMETER	CONDITIONS	MIN.	TYP.	MAX.	UNIT
AM mode (standard L) note 9						
S/N weighted in accordance with CCIR 468-3						
$V_{6(RMS)}$	AF output signal (RMS value)		440	550	660	mV
B_{AF}	AF bandwidth	-3 dB; note 12	0.02	-	120	kHz
THD	total harmonic distortion		-	1	2	%
(S+W)/W	signal-to-weighted-noise ratio	note 10	50	56	-	dB
R_6	output resistance		-	200	-	Ω
V_6	DC potential		-	1.8	-	V
$I_{6(peak)}$	permissible AC output current (peak value)	note 7	-	-	± 0.3	mA
I_6	permissible DC output current		-	-	-1	mA
Standard switch (note 4)						
V_7	peak signal AGC (FM mode)	V_{P1} used	1.8	-	V_{P1}	V
V_7	or switch open-circuit	V_{P2} used	1.8	-	5.5	V
V_7	mean signal AGC (AM mode)		-	-	0.8	V
I_7	switch current					
	at 0 V		-	-	-200	μA
	at V_{P1}		-	-	10	μA
	at V_{P2}	via a 2.2 k Ω series resistor	-	-	2.5	mA
Ripple rejection (note 13)						
AM/AF signal						
α_{RR}	voltage ripple on V_P / voltage ripple on output signal		30	40	-	dB
FM phase noise						
$\Delta f(RMS)$	intercarrier signal		-	10	20	Hz

Quasi split-sound circuit and AM demodulator

TDA3845; TDA3845T

Notes to the characteristics

1. Start of gain control (LOW IF input signal) at -3 dB intercarrier signal reduction at pin 12, AGC mode set to FM or -3 dB AF signal reduction at pin 6, AGC mode set to AM.
2. End of gain control (HIGH IF input signal) at $+1$ dB intercarrier signal expansion at pin 12, AGC mode set to FM or $+1$ dB AF signal expansion at pin 6, AGC mode set to AM.
3. Picture carrier (38.9 MHz) to sound carriers (33.4 MHz/33.158 MHz) ratio: 13/20 dB.
IF input signal (picture carrier at sync pulse); $V_{1-16} = 10$ mV (RMS). Transmitter mode: DSB.
Reference for the (S + W)/W ratio (0 dB) corresponds to the sound modulation where $f = 1$ kHz and frequency deviation $\Delta f = \pm 50$ kHz.
With reduced frequency deviation $\Delta f = \pm 27$ kHz and the (S + W)/W figures will decrease by 5.4 dB.
4. If the device is used only for the B/G standard (no AM), the capacitor at pin 5 can be omitted (pin 5 has to be disconnected). In this event the AGC will always operate as a peak signal AGC and is independent of the voltage at pin 7.
The AM mode can also be used for the B/G standard, consequently standard switching is not required. However, the intercarrier level depends on the video modulation and the AF performance may decrease.
When the IC is operated from a 12 V power supply pin 7 can be connected to a 12 V logic level via a 2.2 k Ω resistor.
5. LC reference circuit for the picture carrier (pins 8 and 9); 68 pF/0.247 μ H; in series with 27 pF:
Q loaded = 40 (Qo = 90); tuned to 38.9 MHz yields quadrature demodulation for the picture carrier which provides optimum video suppression at the intercarrier output (e.g. black-to-white jump of the video modulation). The series capacitor provides a notch at the sound carrier frequency in order to produce more attenuation for the sound carrier in the PC reference channel. The ratio of parallel to series capacitance depends on the ratio of picture to sound carrier frequency which has to be adapted to other TV transmission standards, if required, in accordance with the formula:

$$C_S = C_P (f_{PC}/f_{SC})^2 - C_P$$
 Where:
 C_S = series capacitor
 C = parallel capacitor
 f_{PC} = picture carrier frequency
 f_{SC} = sound carrier frequency
 The result is an improved 'intercarrier buzz' in the stereo system B/G, particularly with 250 kHz video modulation (up to 10 dB improvement in sound Channel 2), or to suppress 350 kHz video modulated beat in the digitally modulated NICAM subcarrier
 In order to optimize the AF signal performance, fine tuning to the optimum S/W at the sound Channel 2 may be achieved by a 250 kHz video modulated square wave.
6. Residual video AM is defined as:

$$m = (A-B)/A$$
 A = intercarrier level at sync pulse
 B = intercarrier level at 100% white video modulation
7. If higher AC output current is required an external resistor must be connected between the output pin and ground in order to increase the bias current of the emitter follower. The permissible maximum DC output current must not be exceeded.

Quasi split-sound circuit and AM demodulator

TDA3845; TDA3845T

8. For all S/N measurements the used vision IF modulator must conform to the following:
Incidental phase modulation for black-to-white jump should be less than 0.5 degrees. Inter-carrier performance, measured with the television demodulator AMF2 (inter-carrier mode weighted S/N ratio) better than 60 dB for 6 kHz sinewave black-to-white video modulation. Weighted S/N ratio of the demodulated inter-carrier signals in accordance with CCIR 468-3, measured with de-emphasis of 50 μ s.
The indicated (S + W)/W ratio X/Y concerns the sound channels 1 and 2 that means demodulated inter-carrier signals of 5.5 and 5.74 MHz respectively.
9. Sound carrier frequency in the range of 30 to 40 MHz modulated with $f = 1$ kHz and a modulation depth of 80%. IF input signal (sound carrier) $V_{1-16} = 10$ mV (RMS).
10. The capacitor at pin 4 can be omitted, however, the (S + W)/W figure for the AM sound (standard L) will be up to 8 dB worse in the IF voltage range 1 mV to 100 mV.
11. When the supply at $V_{P2} = 12$ V the performance will be comparable with the performance when $V_{P1} = 5$ to 8 V. The power supply pin that is not in use should be disconnected.
12. The maximum value given as minimum 120 kHz and typical 700 kHz.
13. Voltage ripple < 200 mV (p-p) at 70 Hz.

Quasi split-sound circuit and AM demodulator

TDA3845; TDA3845T

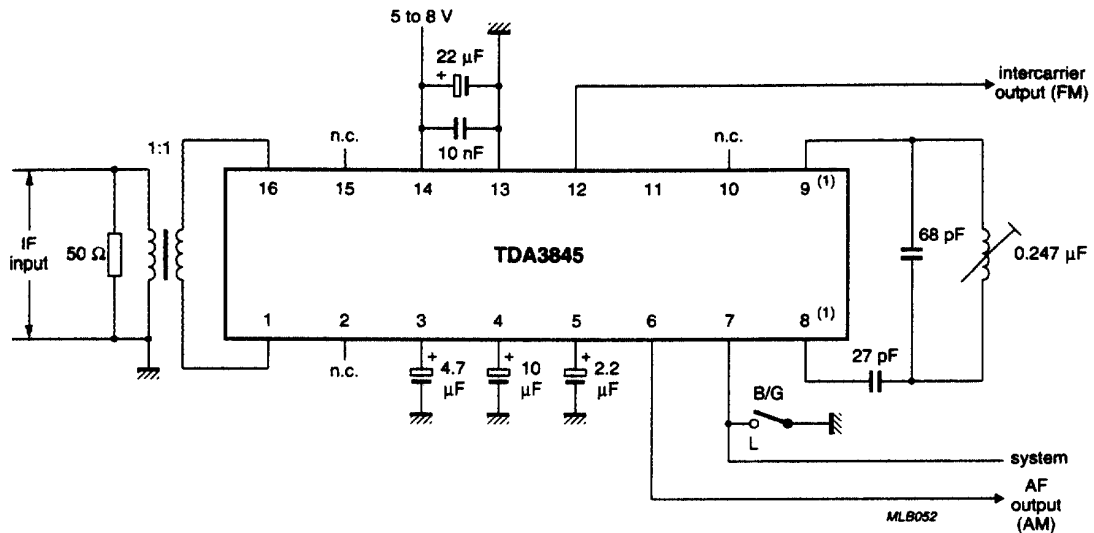

(1) See note 5 to the characteristics.

Fig.3 Test circuit for the +5 V supply.

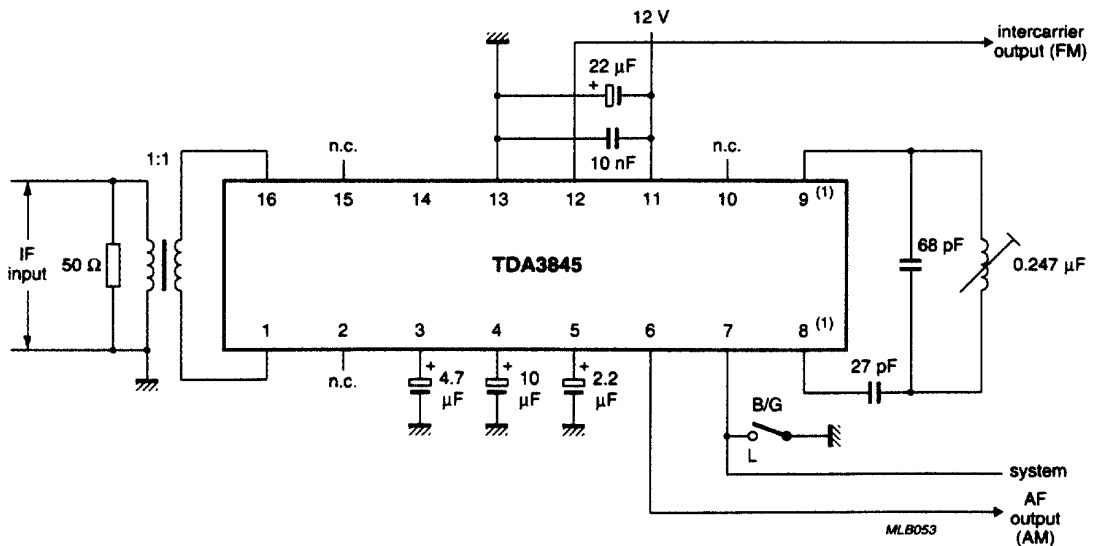

(1) See note 5 to the characteristics.

Fig.4 Test circuit for the +12 V supply; not for TDA3845T.

Quasi split-sound circuit and AM demodulator

TDA3845; TDA3845T

APPLICATION INFORMATION

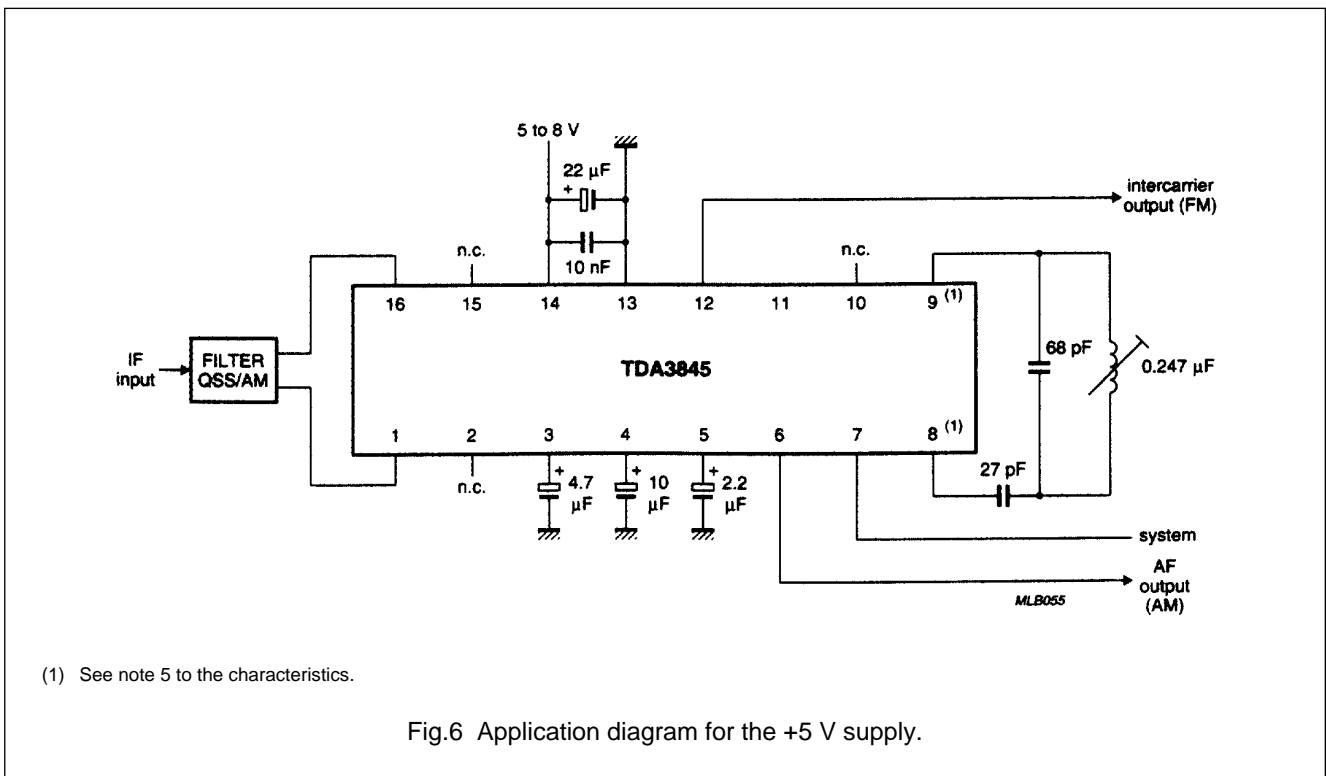
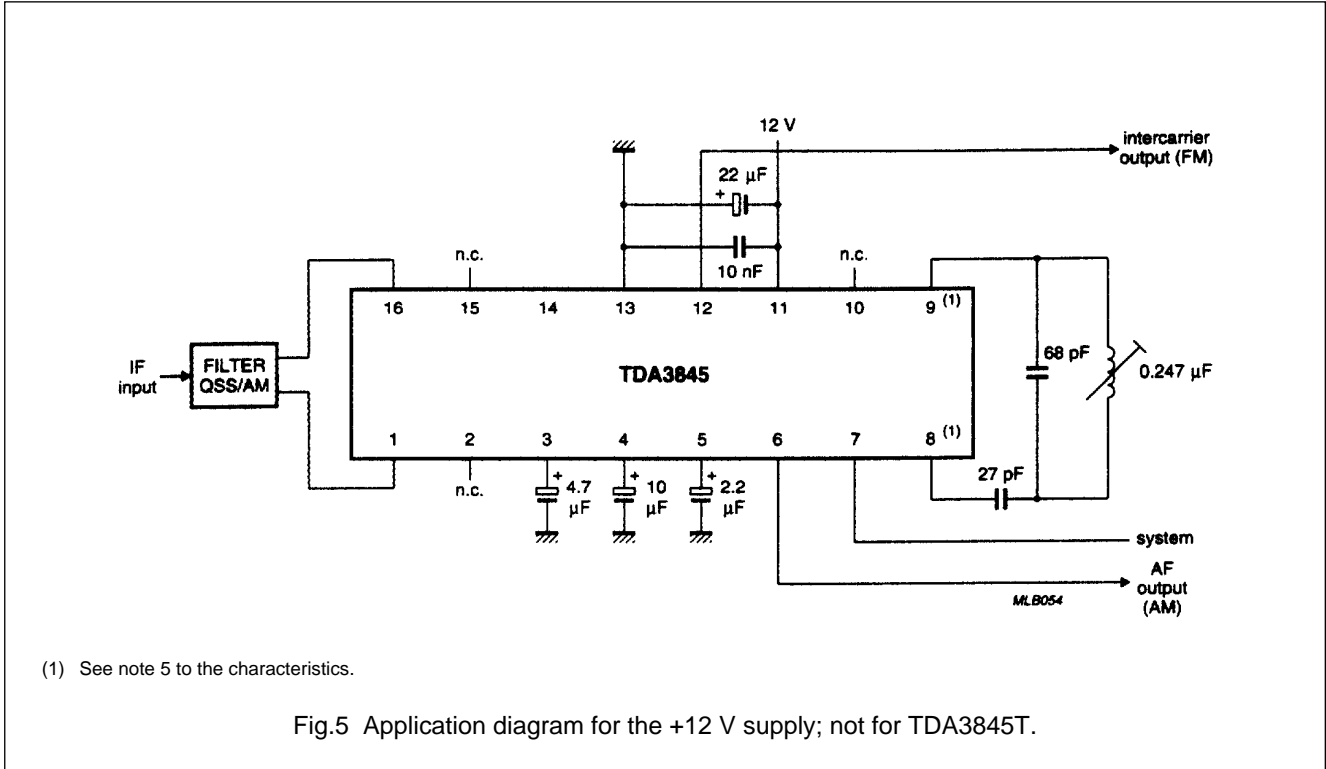

Quasi split-sound circuit and AM demodulator

TDA3845; TDA3845T

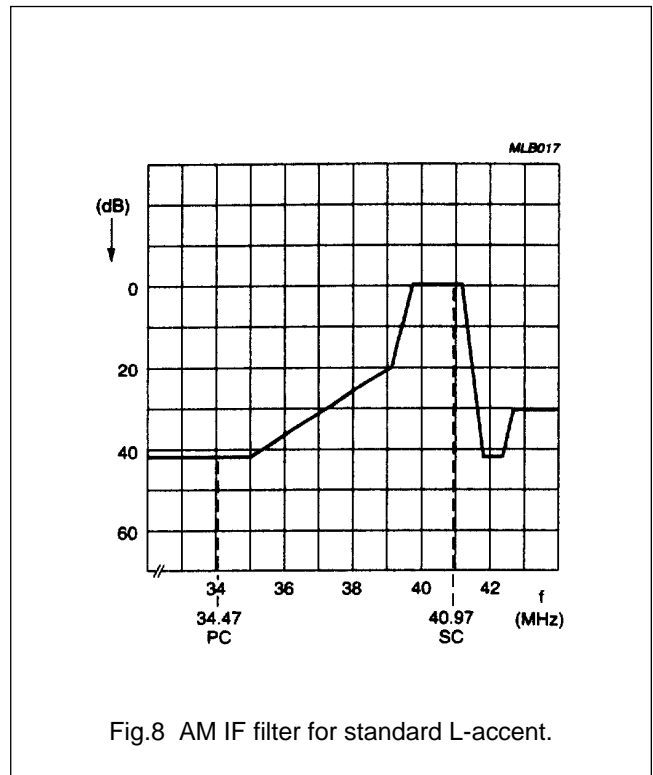
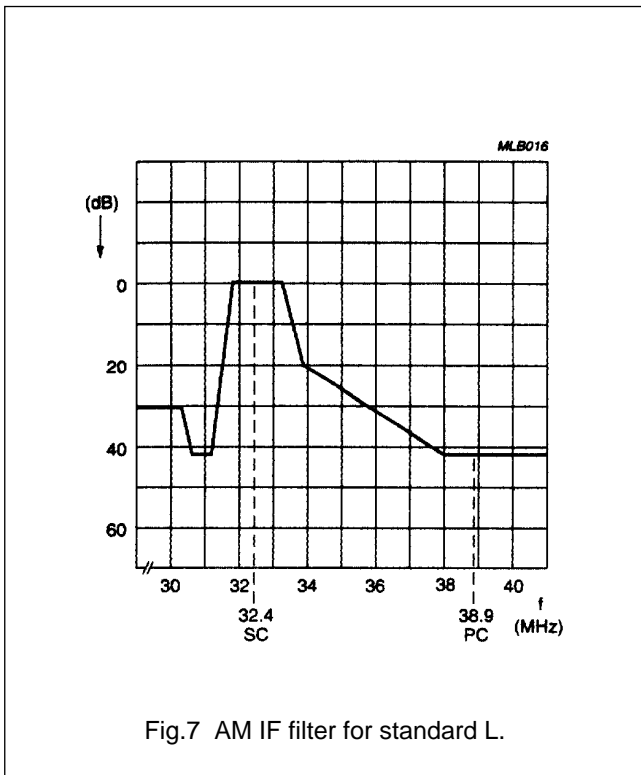

IF filter proposal for AM sound (see Figs 7 and 8)

With an IF filter in accordance with this proposal, the video buzz suppression on the audio output is better than 50 dB (in accordance with CCIR 468-3, $m = 54\%$) for the worst case video modulation with 6 kHz sinewave black-to-white.

Note to figures 7 and 8.

Where SC = sound carrier and PC = picture carrier.

Quasi split-sound circuit and AM demodulator

TDA3845; TDA3845T

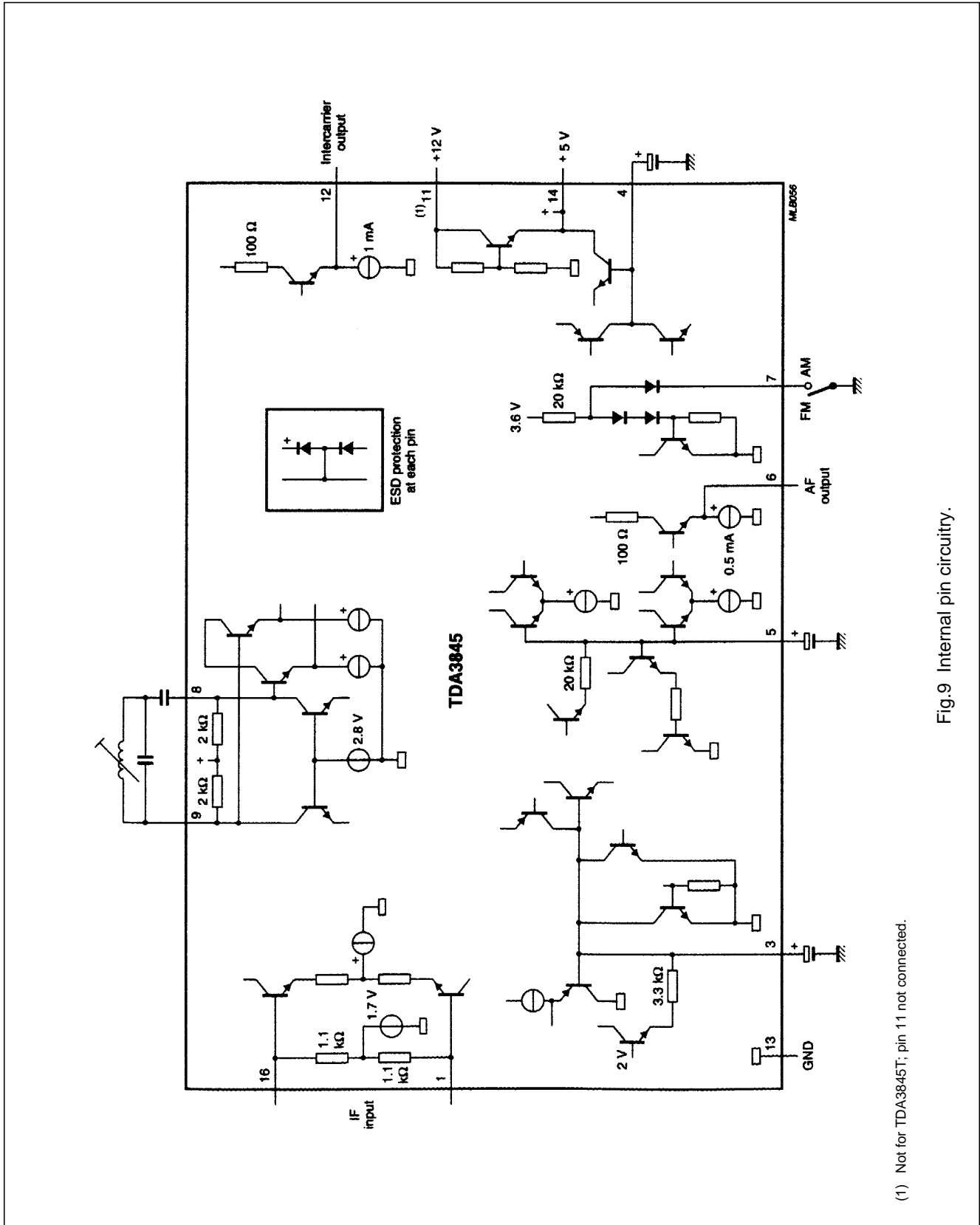
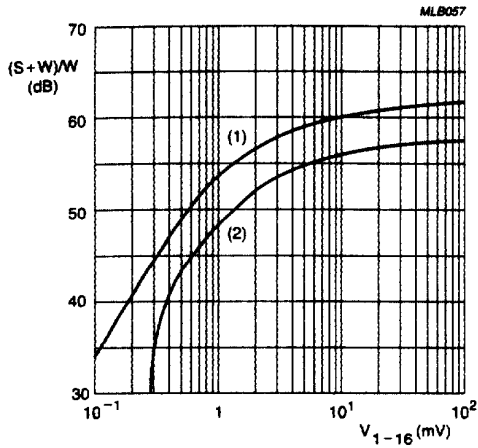

Fig.9 Internal pin circuitry.

Quasi split-sound circuit and AM demodulator

TDA3845; TDA3845T



Picture modulation; 6 kHz sinewave.
 Inter-carrier signal; sound Channel 1 = 5.5 MHz,
 sound Channel 2 = 5.74 MHz.

Fig.10 Response curve of the signal-to-weighted noise ratio of the demodulated inter-carrier signal.

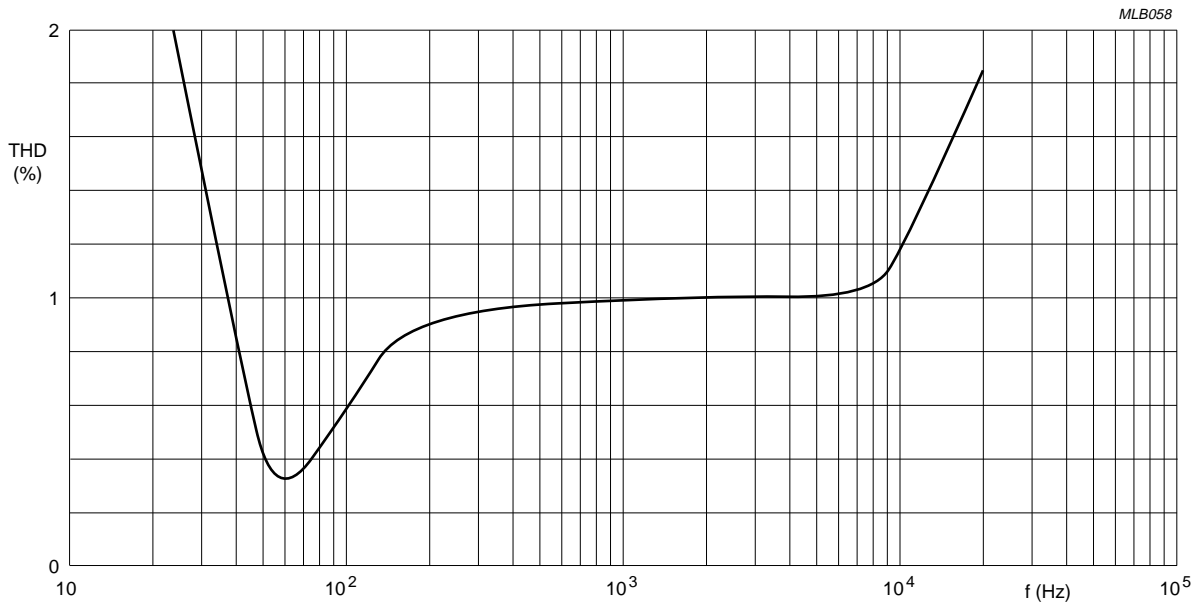

Fig.11 Response curve for the total harmonic distortion of the AM signal.

Quasi split-sound circuit and AM demodulator

TDA3845; TDA3845T

PACKAGE OUTLINES

DIP16: plastic dual in-line package; 16 leads (300 mil); long body

SOT38-1

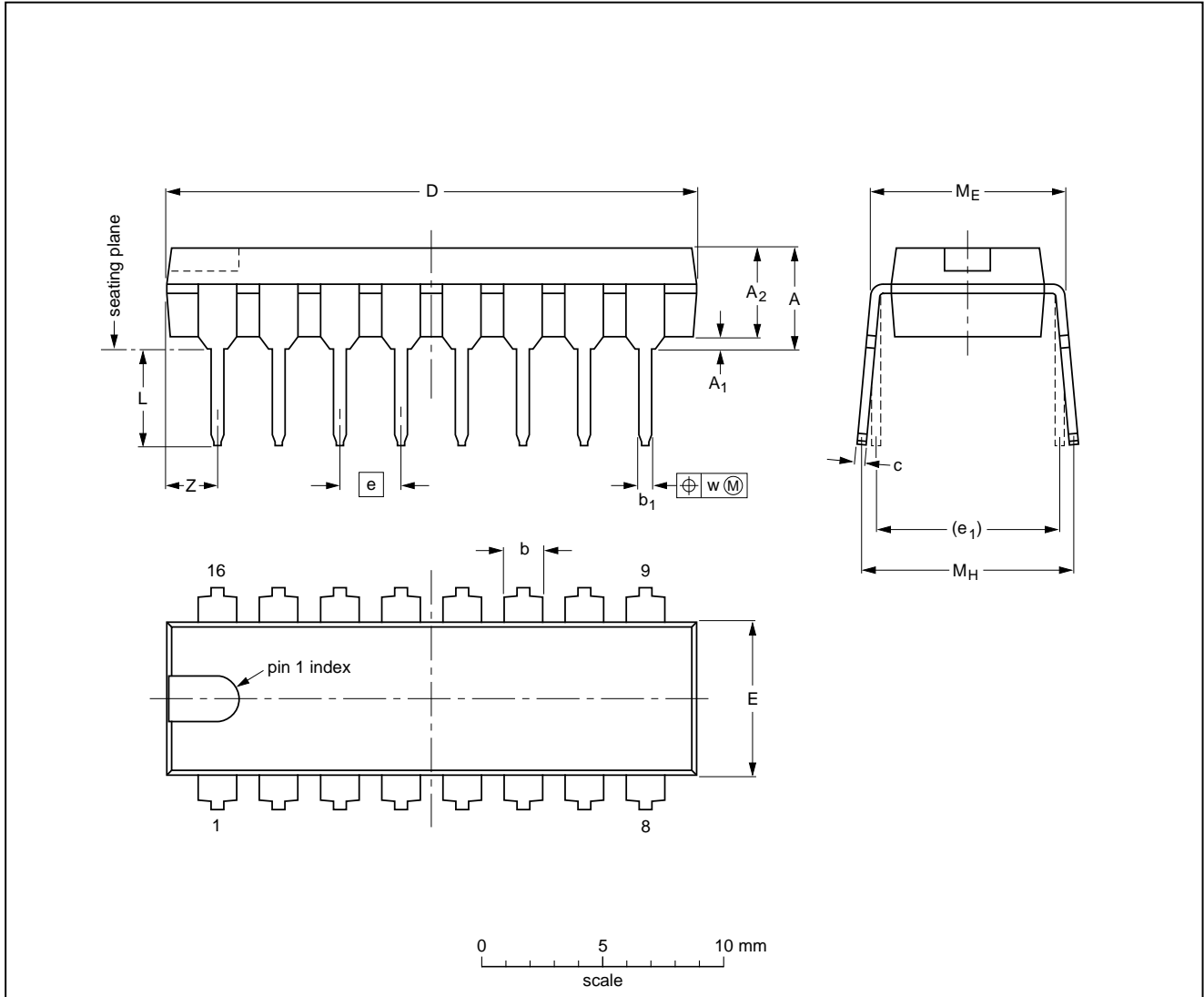

DIMENSIONS (inch dimensions are derived from the original mm dimensions)

UNIT	A max.	A ₁ min.	A ₂ max.	b	b ₁	c	D ⁽¹⁾	E ⁽¹⁾	e	e ₁	L	M _E	M _H	w	Z ⁽¹⁾ max.
mm	4.7	0.51	3.7	1.40 1.14	0.53 0.38	0.32 0.23	21.8 21.4	6.48 6.20	2.54	7.62	3.9 3.4	8.25 7.80	9.5 8.3	0.254	2.2
inches	0.19	0.020	0.15	0.055 0.045	0.021 0.015	0.013 0.009	0.86 0.84	0.26 0.24	0.10	0.30	0.15 0.13	0.32 0.31	0.37 0.33	0.01	0.087

Note

1. Plastic or metal protrusions of 0.25 mm maximum per side are not included.

OUTLINE VERSION	REFERENCES				EUROPEAN PROJECTION	ISSUE DATE
	IEC	JEDEC	EIAJ			
SOT38-1	050G09	MO-001AE				92-10-02 95-01-19

Quasi split-sound circuit and AM demodulator

TDA3845; TDA3845T

SO16: plastic small outline package; 16 leads; body width 3.9 mm

SOT109-1

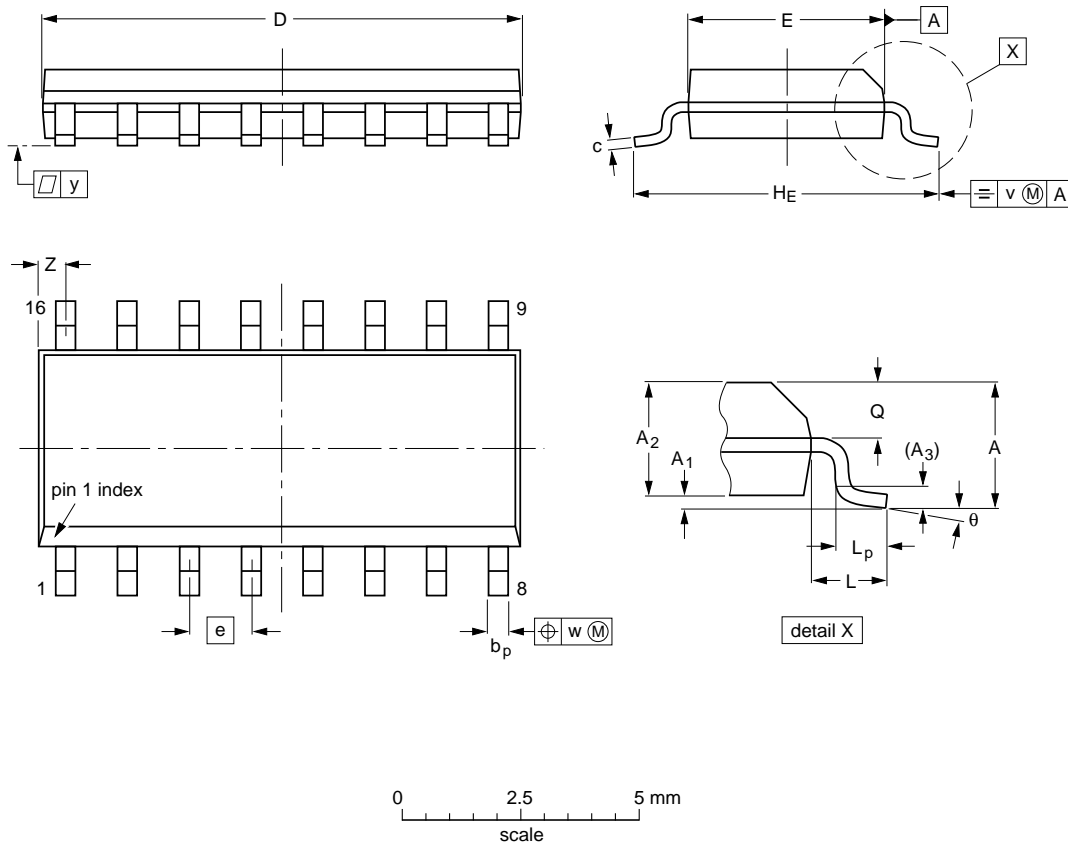

DIMENSIONS (inch dimensions are derived from the original mm dimensions)

UNIT	A max.	A ₁	A ₂	A ₃	b _p	c	D ⁽¹⁾	E ⁽¹⁾	e	H _E	L	L _p	Q	v	w	y	z ⁽¹⁾	θ
mm	1.75	0.25 0.10	1.45 1.25	0.25	0.49 0.36	0.25 0.19	10.0 9.8	4.0 3.8	1.27	6.2 5.8	1.05	1.0 0.4	0.7 0.6	0.25	0.25	0.1	0.7 0.3	8° 0°
inches	0.069	0.0098 0.0039	0.057 0.049	0.01	0.019 0.014	0.0098 0.0075	0.39 0.38	0.16 0.15	0.050	0.24 0.23	0.041	0.039 0.016	0.028 0.020	0.01	0.01	0.004	0.028 0.012	

Note

1. Plastic or metal protrusions of 0.15 mm maximum per side are not included.

OUTLINE VERSION	REFERENCES			EUROPEAN PROJECTION	ISSUE DATE
	IEC	JEDEC	EIAJ		
SOT109-1	076E07S	MS-012AC			91-08-13 95-01-23

Quasi split-sound circuit and AM demodulator

TDA3845; TDA3845T

SOLDERING

Introduction

There is no soldering method that is ideal for all IC packages. Wave soldering is often preferred when through-hole and surface mounted components are mixed on one printed-circuit board. However, wave soldering is not always suitable for surface mounted ICs, or for printed-circuits with high population densities. In these situations reflow soldering is often used.

This text gives a very brief insight to a complex technology. A more in-depth account of soldering ICs can be found in our "IC Package Databook" (order code 9398 652 90011).

DIP

SOLDERING BY DIPPING OR BY WAVE

The maximum permissible temperature of the solder is 260 °C; solder at this temperature must not be in contact with the joint for more than 5 seconds. The total contact time of successive solder waves must not exceed 5 seconds.

The device may be mounted up to the seating plane, but the temperature of the plastic body must not exceed the specified maximum storage temperature ($T_{stg\ max}$). If the printed-circuit board has been pre-heated, forced cooling may be necessary immediately after soldering to keep the temperature within the permissible limit.

REPAIRING SOLDERED JOINTS

Apply a low voltage soldering iron (less than 24 V) to the lead(s) of the package, below the seating plane or not more than 2 mm above it. If the temperature of the soldering iron bit is less than 300 °C it may remain in contact for up to 10 seconds. If the bit temperature is between 300 and 400 °C, contact may be up to 5 seconds.

SO

REFLOW SOLDERING

Reflow soldering techniques are suitable for all SO packages.

Reflow soldering requires solder paste (a suspension of fine solder particles, flux and binding agent) to be applied

to the printed-circuit board by screen printing, stencilling or pressure-syringe dispensing before package placement.

Several techniques exist for reflowing; for example, thermal conduction by heated belt. Dwell times vary between 50 and 300 seconds depending on heating method. Typical reflow temperatures range from 215 to 250 °C.

Preheating is necessary to dry the paste and evaporate the binding agent. Preheating duration: 45 minutes at 45 °C.

WAVE SOLDERING

Wave soldering techniques can be used for all SO packages if the following conditions are observed:

- A double-wave (a turbulent wave with high upward pressure followed by a smooth laminar wave) soldering technique should be used.
- The longitudinal axis of the package footprint must be parallel to the solder flow.
- The package footprint must incorporate solder thieves at the downstream end.

During placement and before soldering, the package must be fixed with a droplet of adhesive. The adhesive can be applied by screen printing, pin transfer or syringe dispensing. The package can be soldered after the adhesive is cured.

Maximum permissible solder temperature is 260 °C, and maximum duration of package immersion in solder is 10 seconds, if cooled to less than 150 °C within 6 seconds. Typical dwell time is 4 seconds at 250 °C.

A mildly-activated flux will eliminate the need for removal of corrosive residues in most applications.

REPAIRING SOLDERED JOINTS

Fix the component by first soldering two diagonally-opposite end leads. Use only a low voltage soldering iron (less than 24 V) applied to the flat part of the lead. Contact time must be limited to 10 seconds at up to 300 °C. When using a dedicated tool, all other leads can be soldered in one operation within 2 to 5 seconds between 270 and 320 °C.

Quasi split-sound circuit and AM demodulator

TDA3845; TDA3845T

DEFINITIONS

Data sheet status	
Objective specification	This data sheet contains target or goal specifications for product development.
Preliminary specification	This data sheet contains preliminary data; supplementary data may be published later.
Product specification	This data sheet contains final product specifications.
Limiting values	
Limiting values given are in accordance with the Absolute Maximum Rating System (IEC 134). Stress above one or more of the limiting values may cause permanent damage to the device. These are stress ratings only and operation of the device at these or at any other conditions above those given in the Characteristics sections of the specification is not implied. Exposure to limiting values for extended periods may affect device reliability.	
Application information	
Where application information is given, it is advisory and does not form part of the specification.	

LIFE SUPPORT APPLICATIONS

These products are not designed for use in life support appliances, devices, or systems where malfunction of these products can reasonably be expected to result in personal injury. Philips customers using or selling these products for use in such applications do so at their own risk and agree to fully indemnify Philips for any damages resulting from such improper use or sale.