

# MC100LVE310

## 3.3V ECL 2:8 Differential Fanout Buffer

The MC100LVE310 is a low voltage, low skew 2:8 differential ECL fanout buffer designed with clock distribution in mind. The device features fully differential clock paths to minimize both device and system skew. The LVE310 offers two selectable clock inputs to allow for redundant or test clocks to be incorporated into the system clock trees.

To ensure that the tight skew specification is met it is necessary that both sides of the differential output are terminated into 50  $\Omega$ , even if only one side is being used. In most applications all eight differential pairs will be used and therefore terminated. In the case where fewer than eight pairs are used it is necessary to terminate at least the output pairs adjacent to the output pair being used in order to maintain minimum skew. Failure to follow this guideline will result in small degradations of propagation delay (on the order of 10–20 ps) of the outputs being used, while not catastrophic to most designs this will result in an increase in skew. Note that the package corners isolate outputs from one another such that the guideline expressed above holds only for outputs on the same side of the package.

The MC100LVE310, as with most ECL devices, can be operated from a positive  $V_{CC}$  supply in LVPECL mode. This allows the LVE310 to be used for high performance clock distribution in +3.3 V systems. Designers can take advantage of the LVE310's performance to distribute low skew clocks across the backplane or the board. In a PECL environment series or Thevenin line terminations are typically used as they require no additional power supplies, if parallel termination is desired a terminating voltage of  $V_{CC}-2.0$  V will need to be provided. For more information on using PECL, designers should refer to Application Note AN1406/D.

The  $V_{BB}$  pin, an internally generated voltage supply, is available to this device only. For single-ended input conditions, the unused differential input is connected to  $V_{BB}$  as a switching reference voltage.  $V_{BB}$  may also rebias AC coupled inputs. When used, decouple  $V_{BB}$  and  $V_{CC}$  via a 0.01  $\mu$ F capacitor and limit current sourcing or sinking to 0.5 mA. When not used,  $V_{BB}$  should be left open.

- 200 ps Part-to-Part Skew
- 50 ps Output-to-Output Skew
- The 100 Series Contains Temperature Compensation
- ESD Protection: >2 KV HBM, >200 V MM
- PECL Mode Operating Range:  $V_{CC}= 3.0$  V to 3.8 V with  $V_{EE}= 0$  V
- NECL Mode Operating Range:  $V_{CC}= 0$  V with  $V_{EE}= -3.0$  V to -3.8 V
- Internal Input Pulldown Resistors
- Q Output will Default LOW with All Inputs Open or at  $V_{EE}$
- Meets or Exceeds JEDEC Spec EIA/JESD78 IC Latchup Test
- Moisture Sensitivity Level 1  
For Additional Information, see Application Note AND8003/D
- Flammability Rating: UL-94 code V-0 @ 1/8",  
Oxygen Index 28 to 34
- Transistor Count = 212 devices



ON Semiconductor®

<http://onsemi.com>

### MARKING DIAGRAM

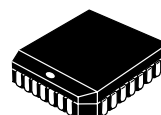

PLCC-28  
FN SUFFIX  
CASE 776

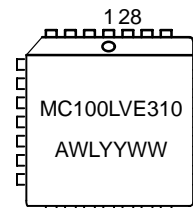

A = Assembly Location  
WL = Wafer Lot  
YY = Year  
WW = Work Week

### ORDERING INFORMATION

Device	Package	Shipping
MC100LVE310FN	PLCC-28	37 Units/Rail
MC100LVE310FNR2	PLCC-28	500 Units/Reel

# MC100LVE310

## LOGIC DIAGRAM AND PINOUT ASSIGNMENT

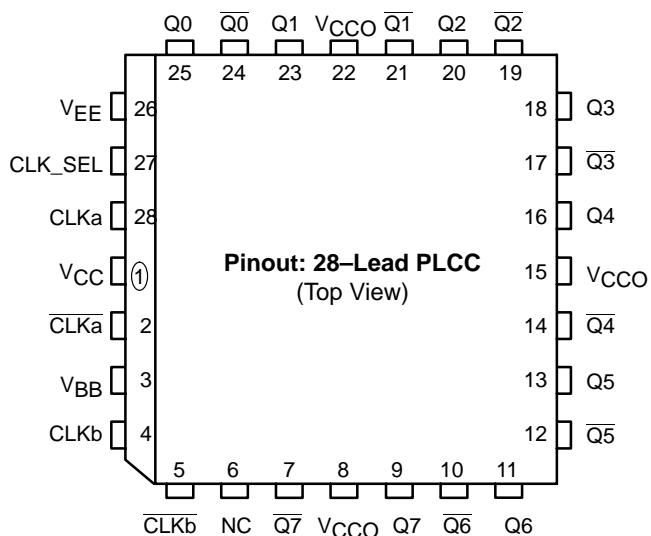

Warning: All  $V_{CC}$ ,  $V_{CCO}$ , and  $V_{EE}$  pins must be externally connected to Power Supply to guarantee proper operation.

## LOGIC SYMBOL

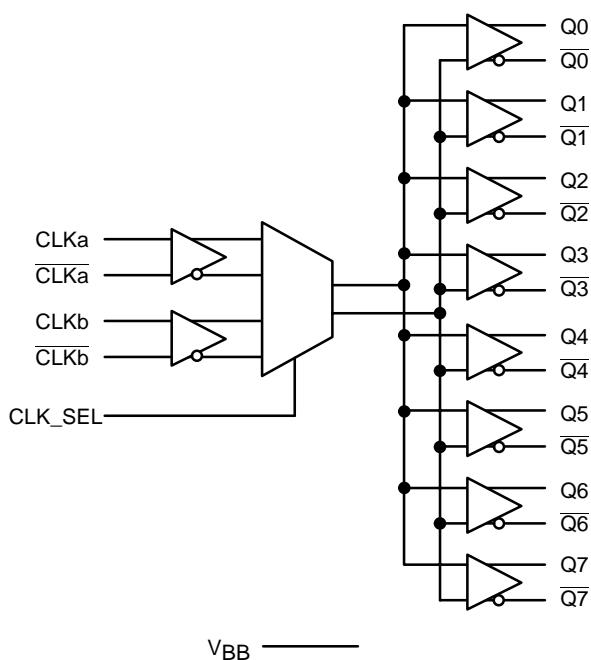

## PIN DESCRIPTION

PIN	FUNCTION
CLKa, $\overline{CLKa}$ ; ,CLKb $\overline{CLKb}$	ECL Differential Input Clocks
Q0:7, $\overline{Q0:7}$	ECL Differential Outputs
CLK_SEL	ECL Input Clock Select
$V_{BB}$	Reference Voltage Output
$V_{CC}$ , $V_{CCO}$	Positive Supply
$V_{EE}$	Negative Supply
NC	No Connect

CLK_SEL	Input Clock
L	CLKa Selected
H	CLKb Selected

## MAXIMUM RATINGS (Note 1)

Symbol	Parameter	Condition 1	Condition 2	Rating	Units
$V_{CC}$	PECL Mode Power Supply	$V_{EE} = 0\text{ V}$		8 to 0	V
$V_{EE}$	NECL Mode Power Supply	$V_{CC} = 0\text{ V}$		-8 to 0	V
$V_I$	PECL Mode Input Voltage NECL Mode Input Voltage	$V_{EE} = 0\text{ V}$ $V_{CC} = 0\text{ V}$	$V_I \leq V_{CC}$ $V_I \geq V_{EE}$	6 to 0 -6 to 0	V V
$I_{out}$	Output Current	Continuous Surge		50 100	mA mA
$I_{BB}$	$V_{BB}$ Sink/Source			$\pm 0.5$	mA
$T_A$	Operating Temperature Range			-40 to +85	$^{\circ}\text{C}$
$T_{stg}$	Storage Temperature Range			-65 to +150	$^{\circ}\text{C}$
$\theta_{JA}$	Thermal Resistance (Junction to Ambient)	0 LFPM 500 LFPM	28 PLCC 28 PLCC	63.5 43.5	$^{\circ}\text{C}/\text{W}$ $^{\circ}\text{C}/\text{W}$
$\theta_{JC}$	Thermal Resistance (Junction to Case)	std bd	28 PLCC	22 to 26 $\pm 5\%$	$^{\circ}\text{C}/\text{W}$
$T_{sol}$	Wave Solder	<2 to 3 sec @ 248 $^{\circ}\text{C}$		265	$^{\circ}\text{C}$

1. Maximum Ratings are those values beyond which device damage may occur.

# MC100LVE310

## LVPECL DC CHARACTERISTICS $V_{CC}=3.3\text{ V}$ ; $V_{EE}=0.0\text{ V}$ (Note 1)

Symbol	Characteristic	-40°C			25°C			85°C			Unit
		Min	Typ	Max	Min	Typ	Max	Min	Typ	Max	
$I_{EE}$	Power Supply Current		55	60		55	60		65	70	mA
$V_{OH}$	Output HIGH Voltage (Note 2)	2215	2295	2420	2275	2345	2420	2275	2345	2420	mV
$V_{OL}$	Output LOW Voltage (Note 2)	1470	1605	1745	1490	1595	1680	1490	1595	1680	mV
$V_{IH}$	Input HIGH Voltage (Single Ended)	2135		2420	2135		2420	2135		2420	mV
$V_{IL}$	Input LOW Voltage (Single Ended)	1490		1825	1490		1825	1490		1825	mV
$V_{BB}$	Output Voltage Reference	1.92		2.04	1.92		2.04	1.92		2.04	V
$V_{IHCMR}$	Input HIGH Voltage Common Mode Range (Differential) (Note 3)	1.8		2.9	1.8		2.9	1.8		2.9	V
$I_{IH}$	Input HIGH Current			150			150			150	$\mu\text{A}$
$I_{IL}$	Input LOW Current	0.5			0.5			0.5			$\mu\text{A}$

NOTE: Devices are designed to meet the DC specifications shown in the above table, after thermal equilibrium has been established. The circuit is in a test socket or mounted on a printed circuit board and transverse air flow greater than 500 lfm is maintained.

1. Input and output parameters vary 1:1 with  $V_{CC}$ .  $V_{EE}$  can vary  $\pm 0.3\text{ V}$ .
2. Outputs are terminated through a 50 ohm resistor to  $V_{CC}-2$  volts.
3.  $V_{IHCMR}$  min varies 1:1 with  $V_{EE}$ , max varies 1:1 with  $V_{CC}$ .  $V_{IHCMR}$  is defined as the range within which the  $V_{IH}$  level may vary, with the device still meeting the propagation delay specification. The  $V_{IL}$  level must be such that the peak to peak voltage is less than 1.0 V and greater than or equal to  $V_{pp}(\text{min})$ .

## LVNECL DC CHARACTERISTICS $V_{CC}=0.0\text{ V}$ ; $V_{EE}=-3.3\text{ V}$ (Note 1)

Symbol	Characteristic	-40°C			25°C			85°C			Unit
		Min	Typ	Max	Min	Typ	Max	Min	Typ	Max	
$I_{EE}$	Power Supply Current		55	60		55	60		65	70	mA
$V_{OH}$	Output HIGH Voltage (Note 2)	-1085	-1005	-880	-1025	-955	-880	-1025	-955	-880	mV
$V_{OL}$	Output LOW Voltage (Note 2)	-1830	-1695	-1555	-1810	-1705	-1620	-1810	-1705	-1620	mV
$V_{IH}$	Input HIGH Voltage (Single Ended)	-1165		-880	-1165		-880	-1165		-880	mV
$V_{IL}$	Input LOW Voltage (Single Ended)	-1810		-1475	-1810		-1475	-1810		-1475	mV
$V_{BB}$	Output Voltage Reference	-1.38		-1.26	-1.38		-1.26	-1.38		-1.26	V
$V_{IHCMR}$	Input HIGH Voltage Common Mode Range (Differential) (Note 3)	-1.5		-0.4	-1.5		-0.4	-1.5		-0.4	V
$I_{IH}$	Input HIGH Current			150			150			150	$\mu\text{A}$
$I_{IL}$	Input LOW Current	0.5			0.5			0.5			$\mu\text{A}$

NOTE: Devices are designed to meet the DC specifications shown in the above table, after thermal equilibrium has been established. The circuit is in a test socket or mounted on a printed circuit board and transverse air flow greater than 500 lfm is maintained.

1. Input and output parameters vary 1:1 with  $V_{CC}$ .  $V_{EE}$  can vary  $\pm 0.3\text{ V}$ .
2. Outputs are terminated through a 50 ohm resistor to  $V_{CC}-2$  volts.
3.  $V_{IHCMR}$  min varies 1:1 with  $V_{EE}$ , max varies 1:1 with  $V_{CC}$ .  $V_{IHCMR}$  is defined as the range within which the  $V_{IH}$  level may vary, with the device still meeting the propagation delay specification. The  $V_{IL}$  level must be such that the peak to peak voltage is less than 1.0 V and greater than or equal to  $V_{pp}(\text{min})$ .

# MC100LVE310

**AC CHARACTERISTICS**  $V_{CC}= 3.3\text{ V}; V_{EE}= 0.0\text{ V}$  or  $V_{CC}= 0.0\text{ V}; V_{EE}= -3.3\text{ V}$  (Note 1.)

Symbol	Characteristic	-40°C			25°C			85°C			Unit
		Min	Typ	Max	Min	Typ	Max	Min	Typ	Max	
$f_{\max}$	Maximum Toggle Frequency		TBD			TBD			TBD		GHz
$t_{\text{PLH}}$ $t_{\text{PHL}}$	Propagation Delay to Output IN (differential) (Note 2.) IN (single-ended) (Note 3.)	525 500		725 750	550 550		750 800	575 600		775 850	ps
$t_{\text{skew}}$	Within-Device Skew (Note 4.) Part-to-Part Skew (Differential)			75 250			50 200			50 200	ps
$t_{\text{JITTER}}$	Cycle-to-Cycle Jitter		TBD			TBD			TBD		ps
$V_{\text{PP}}$	Input Swing (Note 5.)	500		1000	500		1000	500		1000	mV
$t_{\text{r}}/t_{\text{f}}$	Output Rise/Fall Time (20%–80%)	200		600	200		600	200		600	ps

- $V_{EE}$  can vary  $\pm 0.3\text{ V}$ .
- The differential propagation delay is defined as the delay from the crossing points of the differential input signals to the crossing point of the differential output signals.
- The single-ended propagation delay is defined as the delay from the 50% point of the input signal to the 50% point of the output signal.
- The within-device skew is defined as the worst case difference between any two similar delay paths within a single device.
- $V_{\text{PP}}(\text{min})$  is defined as the minimum input differential voltage which will cause no increase in the propagation delay. The  $V_{\text{PP}}(\text{min})$  is AC limited for the LVE310 as a differential input as low as 50 mV will still produce full ECL levels at the output.

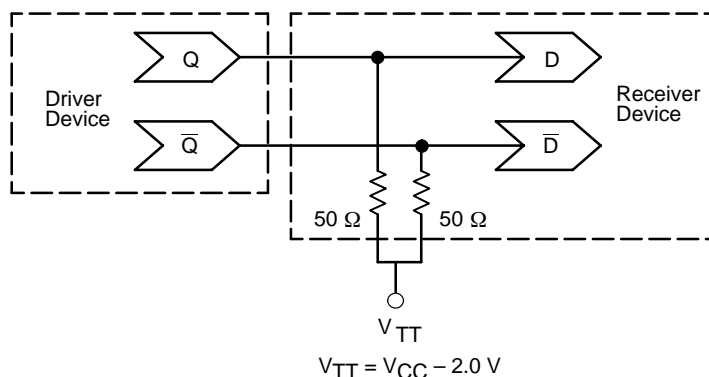

**Figure 1. Typical Termination for Output Driver and Device Evaluation  
(See Application Note AND8020 – Termination of ECL Logic Devices.)**

## Resource Reference of Application Notes

- AN1404** – ECLinPS Circuit Performance at Non-Standard  $V_{\text{IH}}$  Levels
- AN1405** – ECL Clock Distribution Techniques
- AN1406** – Designing with PECL (ECL at +5.0 V)
- AN1503** – ECLinPS I/O SPICE Modeling Kit
- AN1504** – Metastability and the ECLinPS Family
- AN1560** – Low Voltage ECLinPS SPICE Modeling Kit
- AN1568** – Interfacing Between LVDS and ECL
- AN1596** – ECLinPS Lite Translator ELT Family SPICE I/O Model Kit
- AN1650** – Using Wire-OR Ties in ECLinPS Designs
- AN1672** – The ECL Translator Guide
- AND8001** – Odd Number Counters Design
- AND8002** – Marking and Date Codes
- AND8020** – Termination of ECL Logic Devices

# MC100LVE310

## PACKAGE DIMENSIONS

PLCC-28  
FN SUFFIX  
PLASTIC PLCC PACKAGE  
CASE 776-02  
ISSUE E

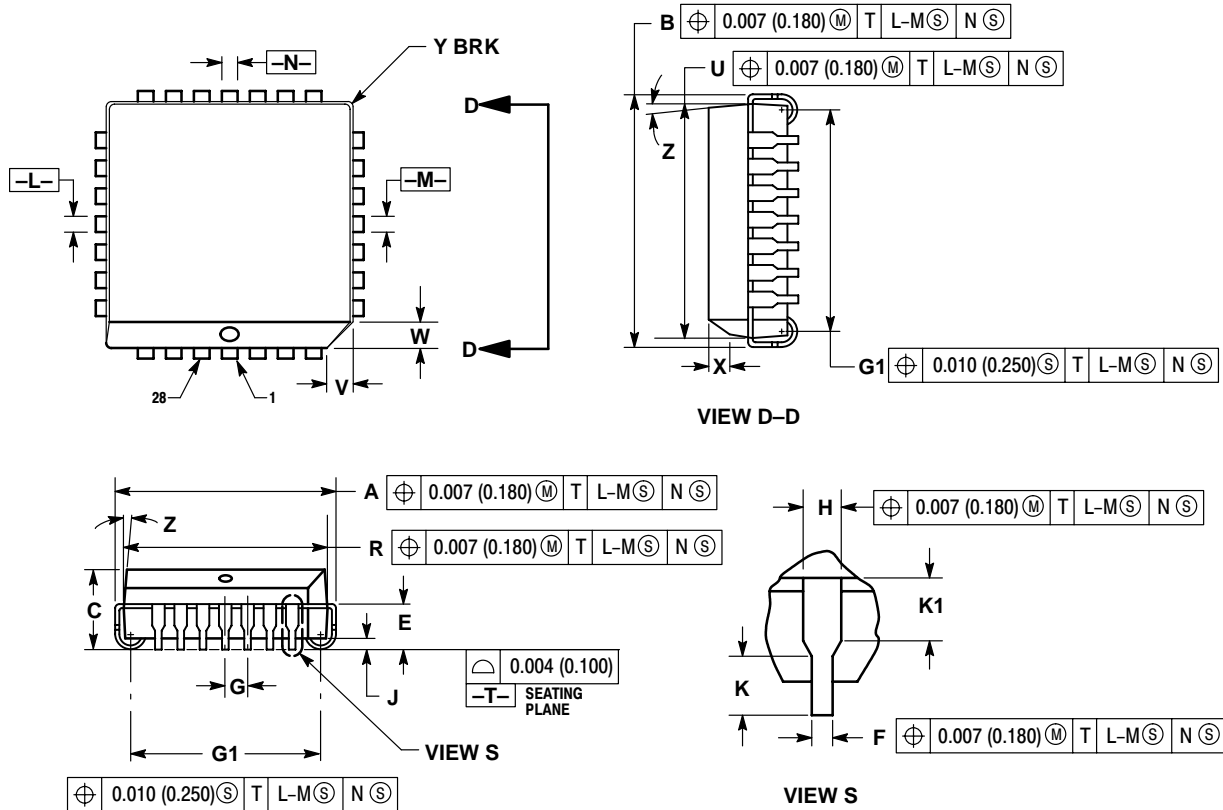

### NOTES:

- DATUMS -L-, -M-, AND -N- DETERMINED WHERE TOP OF LEAD SHOULDER EXITS PLASTIC BODY AT MOLD PARTING LINE.
- DIMENSION G1, TRUE POSITION TO BE MEASURED AT DATUM -T-, SEATING PLANE.
- DIMENSIONS R AND U DO NOT INCLUDE MOLD FLASH. ALLOWABLE MOLD FLASH IS 0.010 (0.250) PER SIDE.
- DIMENSIONING AND TOLERANCING PER ANSI Y14.5M, 1982.
- CONTROLLING DIMENSION: INCH.
- THE PACKAGE TOP MAY BE SMALLER THAN THE PACKAGE BOTTOM BY UP TO 0.012 (0.300). DIMENSIONS R AND U ARE DETERMINED AT THE OUTERMOST EXTREMES OF THE PLASTIC BODY EXCLUSIVE OF MOLD FLASH, TIE BAR BURRS, GATE BURRS AND INTERLEAD FLASH, BUT INCLUDING ANY MISMATCH BETWEEN THE TOP AND BOTTOM OF THE PLASTIC BODY.
- DIMENSION H DOES NOT INCLUDE DAMBAR PROTRUSION OR INTRUSION. THE DAMBAR PROTRUSION(S) SHALL NOT CAUSE THE H DIMENSION TO BE GREATER THAN 0.037 (0.940). THE DAMBAR INTRUSION(S) SHALL NOT CAUSE THE H DIMENSION TO BE SMALLER THAN 0.025 (0.635).

DIM	INCHES		MILLIMETERS	
	MIN	MAX	MIN	MAX
A	0.485	0.495	12.32	12.57
B	0.485	0.495	12.32	12.57
C	0.165	0.180	4.20	4.57
E	0.090	0.110	2.29	2.79
F	0.013	0.019	0.33	0.48
G	0.050 BSC		1.27 BSC	
H	0.026	0.032	0.66	0.81
J	0.020	---	0.51	---
K	0.025	---	0.64	---
R	0.450	0.456	11.43	11.58
U	0.450	0.456	11.43	11.58
V	0.042	0.048	1.07	1.21
W	0.042	0.048	1.07	1.21
X	0.042	0.056	1.07	1.42
Y	---	0.020	---	0.50
Z	2°		10°	
G1	0.410	0.430	10.42	10.92
K1	0.040	---	1.02	---

**Notes**

**Notes**

**ON Semiconductor** and  are registered trademarks of Semiconductor Components Industries, LLC (SCILLC). SCILLC reserves the right to make changes without further notice to any products herein. SCILLC makes no warranty, representation or guarantee regarding the suitability of its products for any particular purpose, nor does SCILLC assume any liability arising out of the application or use of any product or circuit, and specifically disclaims any and all liability, including without limitation special, consequential or incidental damages. "Typical" parameters which may be provided in SCILLC data sheets and/or specifications can and do vary in different applications and actual performance may vary over time. All operating parameters, including "Typicals" must be validated for each customer application by customer's technical experts. SCILLC does not convey any license under its patent rights nor the rights of others. SCILLC products are not designed, intended, or authorized for use as components in systems intended for surgical implant into the body, or other applications intended to support or sustain life, or for any other application in which the failure of the SCILLC product could create a situation where personal injury or death may occur. Should Buyer purchase or use SCILLC products for any such unintended or unauthorized application, Buyer shall indemnify and hold SCILLC and its officers, employees, subsidiaries, affiliates, and distributors harmless against all claims, costs, damages, and expenses, and reasonable attorney fees arising out of, directly or indirectly, any claim of personal injury or death associated with such unintended or unauthorized use, even if such claim alleges that SCILLC was negligent regarding the design or manufacture of the part. SCILLC is an Equal Opportunity/Affirmative Action Employer.

## PUBLICATION ORDERING INFORMATION

### Literature Fulfillment:

Literature Distribution Center for ON Semiconductor  
P.O. Box 5163, Denver, Colorado 80217 USA  
**Phone:** 303-675-2175 or 800-344-3860 Toll Free USA/Canada  
**Fax:** 303-675-2176 or 800-344-3867 Toll Free USA/Canada  
**Email:** ONlit@hibbertco.com

**N. American Technical Support:** 800-282-9855 Toll Free USA/Canada

**JAPAN:** ON Semiconductor, Japan Customer Focus Center  
4-32-1 Nishi-Gotanda, Shinagawa-ku, Tokyo, Japan 141-0031  
**Phone:** 81-3-5740-2700  
**Email:** r14525@onsemi.com

**ON Semiconductor Website:** <http://onsemi.com>

For additional information, please contact your local Sales Representative.