

# LM3590

## Series White LED Driver

### General Description

The LM3590 is a White LED constant current driver capable of supplying up to 3 White LEDs connected in series with 20mA. This device operates over a wide 6V-12.6V input voltage range. The output can accommodate LEDs with a combined forward voltage of up to 11.5V, from a 12V input supply. The LED drive current is programmed by using an external resistor on the I<sub>SET</sub> pin.

LED brightness can be linearly varied up to the programmed LED current by applying a Pulse Width Modulated (PWM) signal to the EN pin of the device. The LED output current of the LM3590 is tightly controlled over temperature and voltage. LED Current matching is guaranteed due to the series configuration of the LEDs. The series topology also simplifies the connection between the White LEDs in the display module and the LM3590 since only one connection is required.

The LM3590 typically draws only 50µA when operating in the no-load condition and draws less than 0.1µA when the device is shut down.

The LM3590 is available in a small 5-pin SOT23 package.

### Features

- Drives up to 3 stacked white LEDs
- 6.0V-12.6V input voltage range
- Up to 20mA LED output current
- Excellent LED current matching guaranteed by series configuration
- Single connection to the White LEDs in the display module
- Tightly controlled programmable current source
- Low shutdown current (0.1µA typ.)
- PWM brightness control
- Very small solution size
- SOT23-5 package: 3mm x 3mm x 1.0mm (LxWxH)

### Applications

- White LED Display Backlights
- Keypad Backlights
- General purpose constant current driver for high forward-voltage LEDs

### Typical Application Circuit

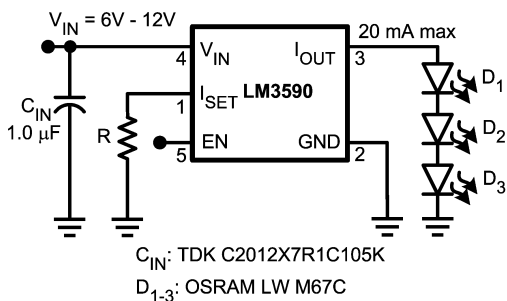

20081301

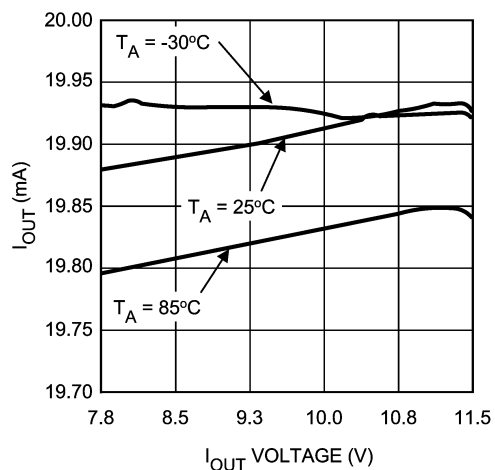

20081305

## Connection Diagram

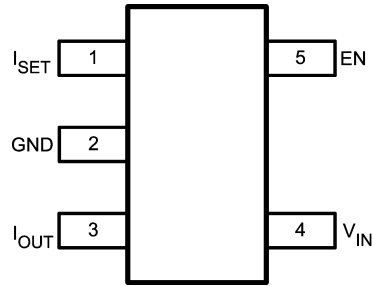

20081302

## Ordering Information

Order Number	Package Description	Package Marking	Supplied As Tape and Reel
LM3590MF	SOT23-5	SABB* $\phi$ Z $\phi$ 1 $\phi$ X	250 Units, Tape and Reel
LM3590MFX	SOT23-5	SABB* $\phi$ Z $\phi$ 1 $\phi$ X	3000 Units, Tape and Reel

## Pin Description

Pin #	Name	Function
1	$I_{SET}$	Programmable LED current Input. The LED current has the following relationship with the resistor used: $R_{SET} = 100 \times (125 \div I_{OUT})$
2	GND	Ground Connection
3	$I_{OUT}$	Constant Current LED Output
4	$V_{IN}$	Power Supply Voltage Input. Input voltage range: 6V-12.6V
5	EN	Device Enable

**Absolute Maximum Ratings** (Notes 1,

2)

If Military/Aerospace specified devices are required, please contact the National Semiconductor Sales Office/Distributors for availability and specifications.

$V_{IN}$	-0.3 to 13.0V Max
EN	-0.3 to ( $V_{IN}+0.3V$ ) w/ 13.0V max

Maximum Junction Temperature ( $T_{JMAX}$ )	150°C
Storage Temperature	-65°C to +150°C
Maximum Lead Temperature (Soldering, 5 sec.)	260°C
ESD Rating (Note 3)	
Human Body Model	1.5kV
Machine Model	200V

**Electrical Characteristics** (Notes 2, 6)

Limits in standard typeface are for  $T_J = 25^\circ\text{C}$  and limits in **boldface** type apply over the full Operating Junction Temperature Range ( $-40^\circ\text{C} \leq T_J \leq +110^\circ\text{C}$ ). Unless otherwise specified,  $C_{IN} = 1 \mu\text{F}$ ,  $V_{IN} = 12.0\text{V}$ ,  $V_{EN} = 3.0\text{V}$ ,  $R_{SET} = 6.19\text{k}\Omega$ ,  $V_{IOUT} = 10.8\text{V}$ .

**Operating Conditions**

Input Voltage Range	6.0V to 12.6V
EN Voltage Range	0V to $V_{IN}$
Ambient Temperature ( $T_A$ ) Range	-40°C to +85°C
(Note 4)	
Junction Temperature ( $T_J$ ) Range	-40°C to +110°C

**Thermal Information**

Junction-to-Ambient Thermal Resistance, SOT23-5 Package ( $\theta_{JA}$ ) (Note 5)	220°C/W
---	---------

Symbol	Parameter	Conditions	Min	Typ	Max	Units
$I_{OUT}$	Output Current Capability	$V_{IN} = 12\text{V}$ $7.5\text{V} \leq V_{IOUT} \leq 11.5\text{V}$	<b>19</b> (-5%)	20	<b>21</b> (+5%)	mA
		$V_{IOUT} = 10.8\text{V}$ $11.3\text{V} \leq V_{IN} \leq 12.6\text{V}$	<b>19</b> (-5%)	20	<b>21</b> (+5%)	
		$R_{SET} = 8.35\text{k}\Omega$		15		
		$R_{SET} = 12.5\text{k}\Omega$		10		
	Output Current Programming			$125 \div R_{SET}$		A
	$I_{OUT}$ ratio to $I_{SET}$			100:1		
$I_Q$	Quiescent Supply Current	$11.3\text{V} \leq V_{IN} \leq 12.6\text{V}$ $R_{SET} = \text{OPEN}$ $I_{OUT} = \text{OPEN}$		50	<b>75</b>	$\mu\text{A}$
$I_{SD}$	Shutdown Supply Current	$V_{IN} = 12.6\text{V}$ $V_{EN} = 0\text{V}$		0.1	<b>1</b>	$\mu\text{A}$
$V_{ISET}$	$I_{SET}$ Reference Voltage			1.25		V
$V_{HR}$	Minimum Current Source Voltage Headroom ( $V_{IN} - V_{IOUT}$ )(Note 7)	$I_{OUT} = 95\%$ nominal		300		mV
$V_{IH}$	Logic Input EN: High level		<b>1.1</b>		<b><math>V_{IN}</math></b>	V
$V_{IL}$	Logic Input EN: Low level		<b>0</b>		<b>0.3</b>	V
$I_{EN}$	Enable Pin Input Current(Note 8)			6		$\mu\text{A}$
$t_{ON}$	Turn-On Time	$I_{OUT} = 90\%$ of steady state		50		$\mu\text{s}$

**Note 1:** Absolute Maximum Ratings indicate limits beyond which damage to the device may occur. Operating Ratings are conditions under which operation of the device is guaranteed. Operating Ratings do not imply guaranteed performance limits. For guaranteed performance limits and associated test conditions, see the Electrical Characteristics table.

**Note 2:** All voltages are with respect to the potential at the GND pin.

**Note 3:** The human-body model is a 100pF capacitor discharged through a 1.5k $\Omega$  resistor into each pin. The machine model is a 220pF capacitor discharged directly into each pin.

**Note 4:** Maximum ambient temperature ( $T_{A-MAX}$ ) is dependent on the maximum operating junction temperature ( $T_{J-MAX-OP} = 110^\circ\text{C}$ ), the maximum power dissipation of the device in the application ( $P_{D-MAX}$ ), and the junction-to-ambient thermal resistance of the part/package in the application ( $\theta_{JA}$ ), as given by the following equation:  $T_{A-MAX} = T_{J-MAX-OP} - (\theta_{JA} \times P_{D-MAX})$ . The ambient temperature operating rating is provided merely for convenience. This part may be operated outside the listed  $T_A$  rating, so long as the junction temperature of the device does not exceed the maximum operating rating of 110°C.

**Note 5:** Junction-to-ambient thermal resistance is highly application and board-layout dependent. In applications where high maximum power dissipation exists, special care must be paid to thermal dissipation issues. For more information on these topics, please refer to the **Power Dissipation** section of this datasheet.

## Electrical Characteristics (Notes 2, 6) (Continued)

**Note 6:** All room temperature limits are 100% tested or guaranteed through statistical analysis. All limits at temperature extremes are guaranteed by correlation using standard Statistical Quality Control methods (SQC). All limits are used to calculate Average Outgoing Quality Level (AOQL). Typical numbers are not guaranteed, but do represent the most likely norm.

**Note 7:** The current source is connected internally between  $V_{IN}$  and  $V_{OUT}$ . The voltage across the current source,  $[V_{IN} - V_{OUT}]$ , is referred to as headroom voltage. For the current source to regulate properly, a minimum headroom voltage must be present across it. Minimum required headroom voltage is proportional to the current flowing through the current source, as dictated by this equation:  $V_{HR-MIN} = 300mV \times (I_{OUT} \div 20mA)$ .

**Note 8:** An internal 500k $\Omega$  pull-down resistor is connected between the EN and GND pins.

## Functional Block Diagram

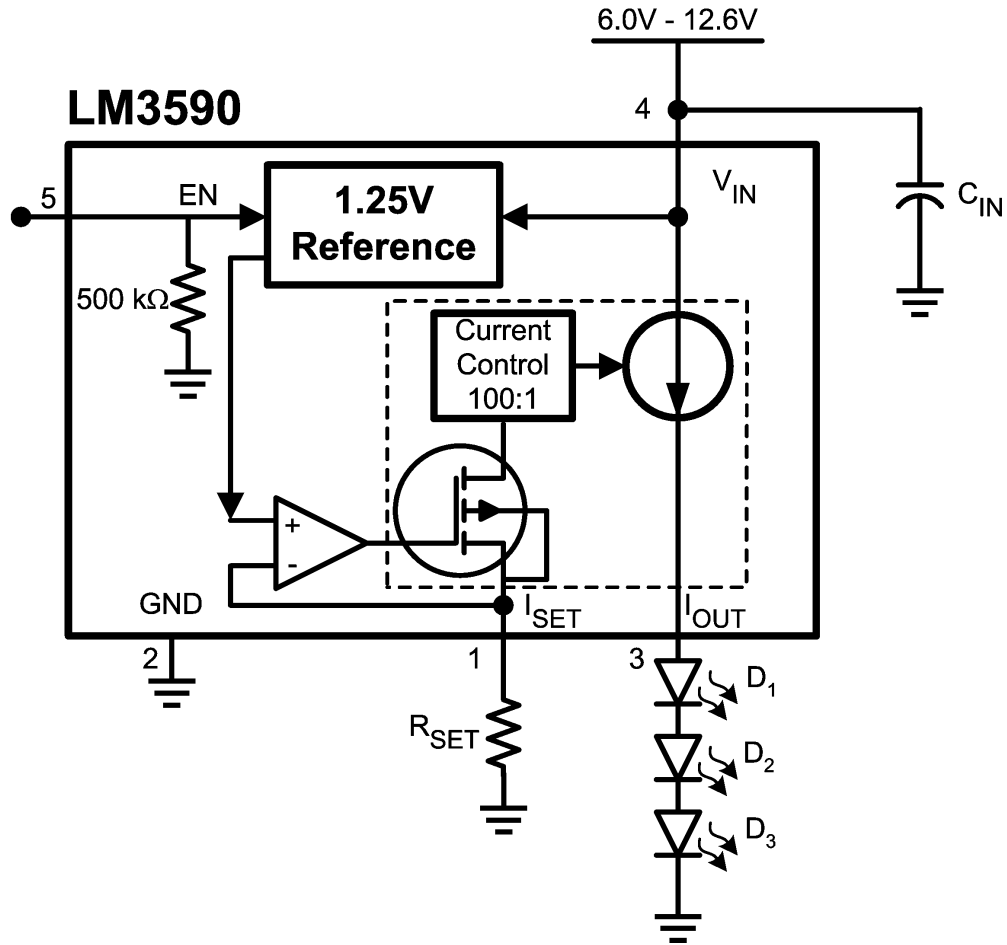

20081314

**Typical Performance Characteristics** Unless otherwise specified,  $C_{IN} = 1\mu F$ ,  $V_{IN} = 12.0V$ ,  $V_{EN} = 3.0V$ ,  $V_{IOUT} = 10.8V$ ,  $R_{SET} = 6.19k\Omega$ ,  $T_A = 25^\circ C$ .  $C_{IN}$  is a low ESR multi-layer ceramic capacitor (MLCC).

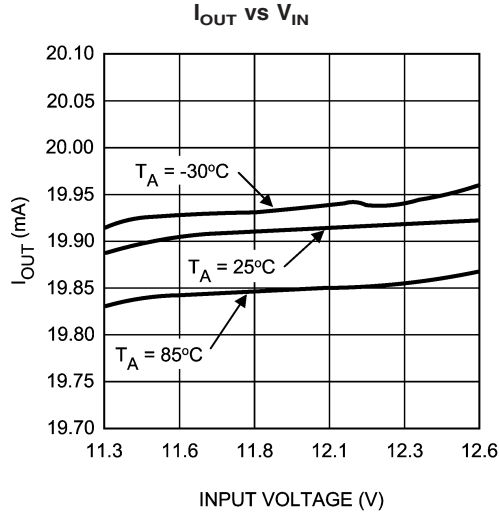

20081304

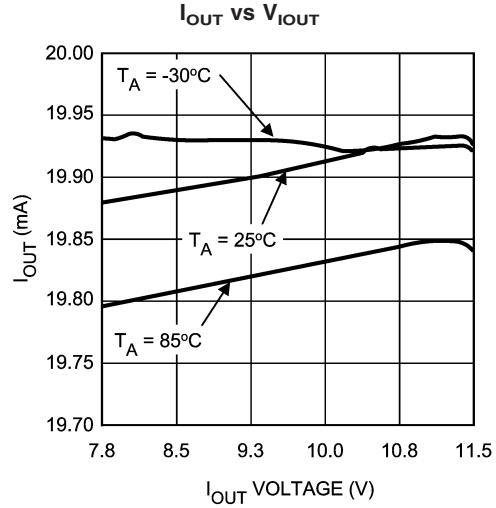

20081305

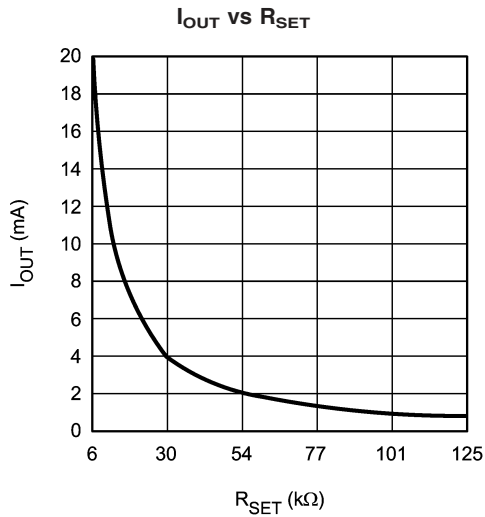

20081306

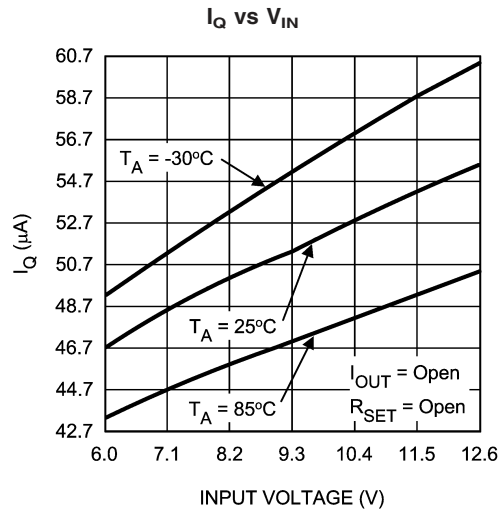

20081307

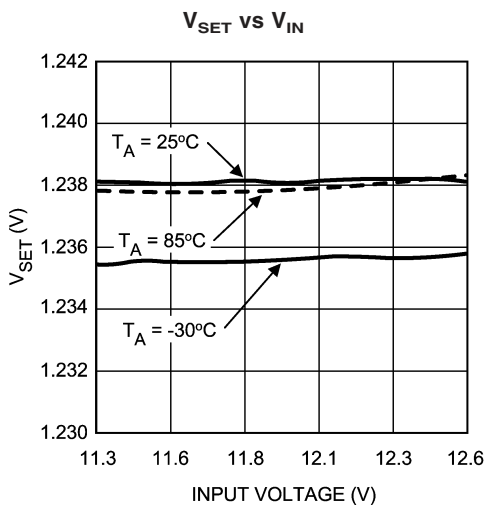

20081308

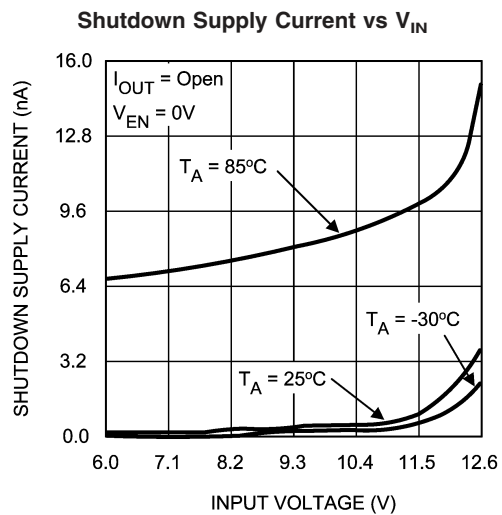

20081309

**Typical Performance Characteristics** Unless otherwise specified,  $C_{IN} = 1\mu F$ ,  $V_{IN} = 12.0V$ ,  $V_{EN} = 3.0V$ ,  $V_{IOUT} = 10.8V$ ,  $R_{SET} = 6.19k\Omega$ ,  $T_A = 25^\circ C$ .  $C_{IN}$  is a low ESR multi-layer ceramic capacitor (MLCC). (Continued)

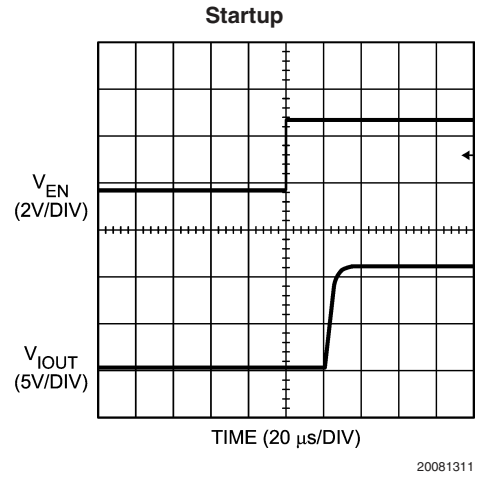
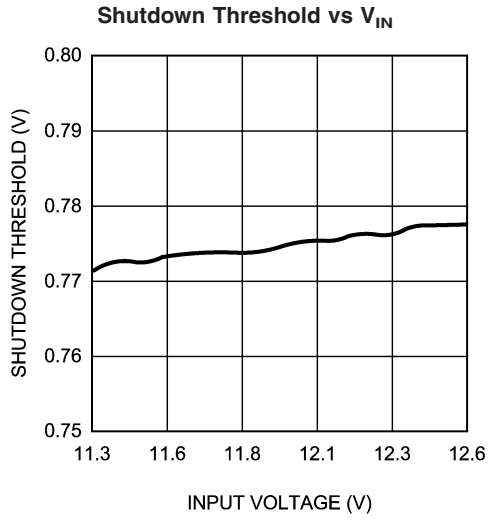

## Application Information

### CIRCUIT DESCRIPTION

The LM3590 is a constant current series White-LED Driver, providing up to 20mA from an input voltage between 7.5V to 12.6V. To set the LED drive current, the LM3590 uses a resistor connected to the  $I_{SET}$  pin to set a reference current. This reference current is then multiplied and mirrored to the constant current output,  $I_{OUT}$ . The LED brightness can be controlled by applying a PWM (Pulse Width Modulation) signal to the Enable pin (EN). (see **PWM BRIGHTNESS CONTROL PROCEDURES** section).

### ENABLE MODE

The Enable pin (EN) disables the part and reduces the quiescent current to 0.1  $\mu$ A (typ.). The LM3590 has an active-high enable pin (LOW = shut down, HIGH = operating). The LM3590 EN pin can be driven with a low-voltage CMOS logic signal (1.5V logic, 1.8V logic, etc). There is an internal 500k $\Omega$  pull-down between the EN and GND pins of the LM3590.

### CAPACITOR SELECTION

Although not required for normal operation, a capacitor can be added to the voltage input of the LM3590 to reduce line noise. A surface-mount multi-layer ceramic capacitor (MLCC) is recommended. MLCCs are small, inexpensive and have very low equivalent series resistance (ESR,  $\leq 15\text{m}\Omega$  typ.). MLCCs with a X5R or X7R temperature characteristic are preferred for use with the LM3590. *Table 1. Ceramic Capacitor Manufacturers* lists suggested capacitor suppliers for the typical application circuit.

**TABLE 1. Ceramic Capacitor Manufacturers**

Manufacturer	Contact
TDK	www.component.tdk.com
Murata	www.murata.com
Taiyo Yuden	www.t-yuden.com

### LED SELECTION

The LM3590 is designed to drive up to 3 LEDs with the combined forward voltages of the LEDs being no greater than 11.5V, when using a 12V input supply. The typical and maximum diode forward voltage depends highly on the manufacturer and their technology. *Table 2. White LED Selection* lists two suggested manufacturers. LED Forward current matching is guaranteed by design, due to the series LED configuration of the LM3590.

**TABLE 2. White LED Selection**

Manufacturer	Contact
Osram	www.osram-os.com
Nichia	www.nichia.com

### LED HEADROOM VOLTAGE ( $V_{HR}$ )

A single current source is connected internally between  $V_{IN}$  and  $I_{OUT}$ . The voltage across the current source, ( $V_{IN} - V_{I_{OUT}}$ ), is referred to as headroom voltage ( $V_{HR}$ ). The current source requires a sufficient amount of headroom voltage to be present across it in order to regulate properly. Minimum

required headroom voltage is proportional to the current flowing through the current source, as dictated by the equation:

$$V_{HR-MIN} = k_{HR} \times I_{OUT}$$

The parameter  $k_{HR}$ , typically 15mV/mA in the LM3590, is a proportionality constant that represents the ON-resistance of the internal current mirror transistors. For worst-case design calculations, using a  $k_{HR}$  of 20mV/mA is recommended. (Worst-case recommendation accounts for parameter shifts from part-to-part variation and applies over the full operating temperature range). *Figure 1* shows how output current of the LM3590 varies with respect to headroom voltage.

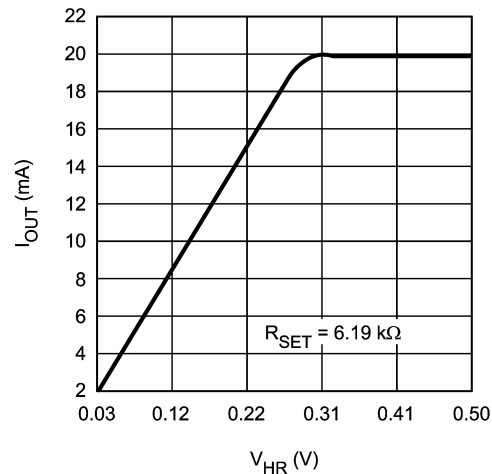

20081312

**FIGURE 1.  $I_{OUT}$  vs  $V_{HR}$**

$$V_{HR} = V_{IN} - V_{I_{OUT}}$$

$$V_{IN} = 12.0V$$

On the flat part of the graph, the current is regulated properly as there is sufficient headroom voltage for regulation. On the sloping part of the graph the headroom voltage is too small, the current source is squeezed, and the current drive capability is limited. Thus, operating the LM3590 with insufficient headroom voltage across the current source should be avoided.

### $I_{SET}$ PIN

An external resistor,  $R_{SET}$ , connected to the  $I_{SET}$  pin sets the output current. The internal current mirror sets the series LED output current with a 100:1 ratio to the current through  $R_{SET}$ . The current matching through each LED is guaranteed by the series LED drive topology. The following equation approximates the LED current:

$$I_{OUT} = 100 \times (1.25V \div R_{SET}) \text{ (Amps)}$$

### PWM BRIGHTNESS CONTROL PROCEDURES

The brightness of the LEDs can be linearly varied from zero up to the maximum programmed current level by applying a Pulse-Width-Modulated signal to the EN pin of the LM3590. The following procedures illustrate how to program the LED drive current and adjust the output current level using a PWM signal.

1. Determine the maximum desired  $I_{OUT}$  current. Use the  $I_{OUT}$  equation to calculate  $R_{SET}$

## Application Information (Continued)

2. Brightness control can be implemented by pulsing a signal at the EN pin. LED brightness is proportional to the duty cycle (D) of the PWM signal. For linear brightness control over the full duty cycle adjustment range, the PWM frequency (f) should be limited to accommodate the turn-on time ( $T_{ON} = 50\mu s$ ) of the device.

$$D \times (1/f) > T_{ON}$$

$$f_{MAX} = D_{MIN} \div T_{ON}$$

If the PWM frequency is much less than 100Hz, flicker may be seen in the LEDs. For the LM3590, zero duty cycle will turn off the LEDs and a 50% duty cycle will result in an average  $I_{OUT}$  being half of the programmed LED current. For example, if  $R_{SET}$  is set to program 15mA, a 50% duty cycle will result in an average  $I_{LED}$  of 7.5mA.

### POWER DISSIPATION

The power dissipation ( $P_{DISSIPATION}$ ) and junction temperature ( $T_J$ ) can be approximated with the equations below.  $P_{IN}$  is the product of the input current and input voltage,  $P_{IOUT}$  is

the power consumed by the LEDs,  $T_A$  is the ambient temperature, and  $\theta_{JA}$  is the junction-to-ambient thermal resistance for the SOT23-5 package.  $V_{IN}$  is the input voltage to the LM3590,  $V_{IOUT}$  is the sum of the forward voltages of LEDs connected to the  $I_{OUT}$  pin, and  $I_{OUT}$  is the programmed LED current.

$$P_{DISSIPATION} = P_{IN} - P_{IOUT}$$

$$= (V_{IN} \times I_{OUT}) - (V_{IOUT} \times I_{OUT})$$

$$T_J = T_A + (P_{DISSIPATION} \times \theta_{JA})$$

The junction temperature rating takes precedence over the ambient temperature rating. The LM3590 may be operated outside the ambient temperature rating, so long as the junction temperature of the device does not exceed the maximum operating rating of 110°C. The maximum ambient temperature rating must be derated in applications where high power dissipation and/or poor thermal resistance causes the junction temperature to exceed 110°C.

### Application Circuits

Figure 2 shows how to program the LED current to four different DC levels using two digital logic signals. The programmed LED current is a function of the equivalent resis-

tance on the  $I_{SET}$  pin ( $R_{ISET}$ ), resulting from the logic signals on SET1 and SET2. Example values for  $R_1$ ,  $R_2$ , and  $R_{SET}$  and the resulting 4 current levels are shown below.

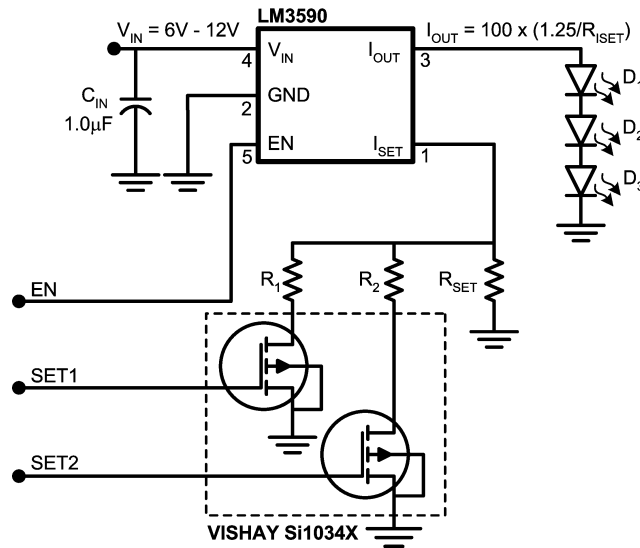

20081313

FIGURE 2. Example:  $R_1 = 15.8k\Omega$ ,  $R_2 = 31.6k\Omega$ ,  $R_{SET} = 31.6k\Omega$

TABLE 3. Digital LED Current Programming

EN	SET1	SET2	$R_{ISET}$	Example $R_{ISET}$	Example $I_{OUT}$
0	X	X	Shutdown	Shutdown	Shutdown
1	1	1	$R_{SET} \parallel R_1 \parallel R_2$	$31.6k\Omega \parallel 15.k\Omega \parallel 31.6k\Omega$	16mA
1	1	0	$R_{SET} \parallel R_1$	$31.6k\Omega \parallel 15.k\Omega$	12mA
1	0	1	$R_{SET} \parallel R_2$	$31.6k\Omega \parallel 31.6k\Omega$	8mA
1	0	0	$R_{SET}$	31.6kΩ	4mA



**Physical Dimensions** inches (millimeters) unless otherwise noted

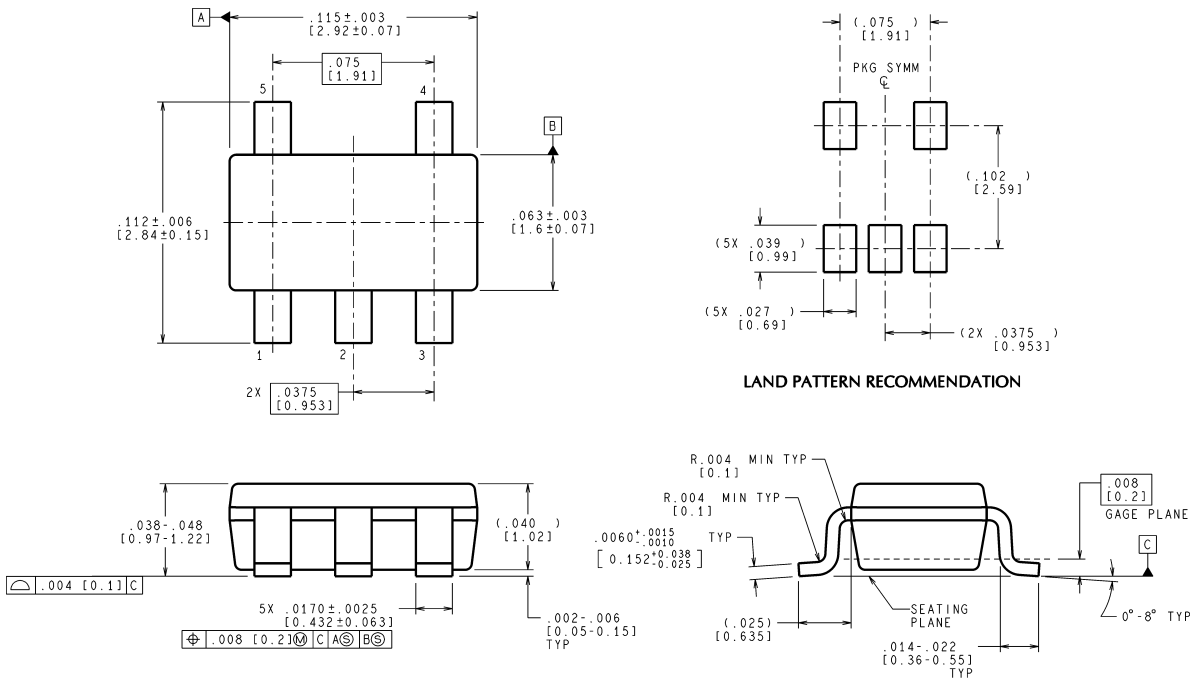

CONTROLLING DIMENSION IS INCH  
VALUES IN [ ] ARE MILLIMETERS

**5 Lead Small Outline Package (SOT23-5)  
NS Package Number MF05A**

MF05A (Rev B)

**LIFE SUPPORT POLICY**

NATIONAL'S PRODUCTS ARE NOT AUTHORIZED FOR USE AS CRITICAL COMPONENTS IN LIFE SUPPORT DEVICES OR SYSTEMS WITHOUT THE EXPRESS WRITTEN APPROVAL OF THE PRESIDENT AND GENERAL COUNSEL OF NATIONAL SEMICONDUCTOR CORPORATION. As used herein:

1. Life support devices or systems are devices or systems which, (a) are intended for surgical implant into the body, or (b) support or sustain life, and whose failure to perform when properly used in accordance with instructions for use provided in the labeling, can be reasonably expected to result in a significant injury to the user.
2. A critical component is any component of a life support device or system whose failure to perform can be reasonably expected to cause the failure of the life support device or system, or to affect its safety or effectiveness.

**BANNED SUBSTANCE COMPLIANCE**

National Semiconductor certifies that the products and packing materials meet the provisions of the Customer Products Stewardship Specification (CSP-9-111C2) and the Banned Substances and Materials of Interest Specification (CSP-9-111S2) and contain no "Banned Substances" as defined in CSP-9-111S2.

**National Semiconductor**  
Americas Customer Support Center  
Email: new.feedback@nsc.com  
Tel: 1-800-272-9959

**National Semiconductor**  
Europe Customer Support Center  
Fax: +49 (0) 180-530 85 86  
Email: europe.support@nsc.com  
Deutsch Tel: +49 (0) 69 9508 6208  
English Tel: +44 (0) 870 24 0 2171  
Français Tel: +33 (0) 1 41 91 8790

**National Semiconductor**  
Asia Pacific Customer Support Center  
Email: ap.support@nsc.com

**National Semiconductor**  
Japan Customer Support Center  
Fax: 81-3-5639-7507  
Email: jpn.feedback@nsc.com  
Tel: 81-3-5639-7560

www.national.com