



Chip Pak High Volume Pressure Sensor for Disposable, Backside Pressure Applications

Motorola has developed a low cost, high volume, miniature pressure sensor package which is ideal as a sub-module component or a disposable unit. The unique concept of the Chip Pak allows great flexibility in system design while allowing an economic solution for the designer. This new chip carrier package uses Motorola's unique sensor die with its patented, piezoresistive implant technology, along with the added feature of on-chip, thin-film temperature compensation and calibration.

Features:

- Low Cost
- Patented piezoresistive strain gauge implant, temperature compensation and calibration all integrated on a single, monolithic sensor die.
- Pressure Range Available: 0–300 mmHg
- Polysulfone (Mindell S–1000) Case Material (Medical, Class VI Approved)

Motorola is offering the Chip Pak option package. Application-specific parts will have an "SPX" prefix, followed by a four digit number, unique to the specific customer. Devices will be shipped in a tape and reel packaging.

NOTE: The die and wire bonds are exposed on the front side of the Chip Pak (pressure is applied to the backside of the device). Front side die and wire protection must be provided in the customer's housing. Use caution when handling the devices during all processes.

MAXIMUM RATINGS

Rating	Symbol	Value	Unit
Overpressure (Backside)	P_{max}	125	PSI
Burst Pressure	P_{burst}	1000	kPa
Supply Voltage	V_{Smax}	10	Vdc
Storage Temperature	T_{stg}	–25 to +85	°C
Operating Temperature	T_A	+15 to +40	°C

Motorola's MPX2300DT1 Pressure Sensors. Motorola's MPX2300DT1 pressure sensor has been designed for medical usage by combining the performance of Motorola's shear stress pressure sensor design and the use of biomedically approved materials. Materials with a proven history in medical situations have been chosen to provide a sensor that can be used with confidence in applications, such as invasive blood pressure monitoring. It can be sterilized using ethylene oxide. The portions of the pressure sensor that are required to be biomedically approved are the rigid housing and the gel coating.

The rigid housing is molded from a white, medical grade polysulfone that has passed extensive biological testing including: tissue culture test, rabbit implant, hemolysis, intracutaneous test in rabbits, and system toxicity, USP.

A silicone dielectric gel that has been used extensively in implants covers the silicon piezoresistive sensing element. The gel is a nontoxic, nonallergenic polymer system which passes pyrogen testing, as well as meeting all USP XX Biological Testing Class VI requirements. The properties of the gel allow it to transmit pressure uniformly to the diaphragm surface, while isolating the internal electrical connections from the corrosive effects of fluids, such as saline solution. The gel provides electrical isolation sufficient to withstand defibrillation testing, as specified in the proposed Association for the Advancement of Medical Instrumentation (AAMI) Standard for blood pressure transducers. A biomedically approved opaque filler in the gel prevents bright operating room lights from affecting the performance of the sensor.

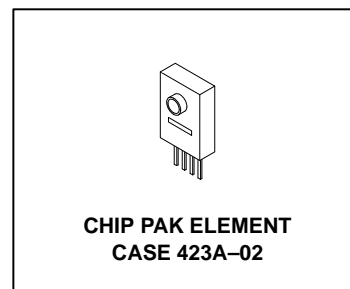
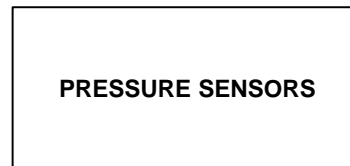

PIN NUMBER			
1	V_S	3	S–
2	S+	4	Gnd

Senseon and X–ducer are trademarks of Motorola, Inc.



MPX2300DT1

OPERATING CHARACTERISTICS ($V_S = 6 \text{ Vdc}$, $T_A = 25^\circ\text{C}$ unless otherwise noted)

Characteristics	Symbol	Min	Typ	Max	Unit
Pressure Range	P_{OP}	0	—	300	mmHg
Supply Voltage ⁽⁸⁾	V_S	—	6.0	10	Vdc
Supply Current	I_o	—	1.0	—	mAdc
Zero Pressure Offset	V_{off}	-0.75	—	0.75	mV
Sensitivity	—	4.95	5.0	5.05	$\mu\text{V/V/mmHg}$
Full Scale Span ⁽¹⁾	V_{FSS}	2.976	3.006	3.036	mV
Linearity + Hysteresis ⁽²⁾	—	-2.0	—	2.0	
Temperature Effect on Sensitivity	TCS	-0.1	—	+0.1	$\% / ^\circ\text{C}$
Temperature Effect on Full Scale Span ⁽³⁾	TCV_{FSS}	-0.1	—	+0.1	$\% / ^\circ\text{C}$
Temperature Effect on Offset ⁽⁴⁾	TCV_{off}	-9.0	—	+9.0	$\mu\text{V} / ^\circ\text{C}$
Input Impedance	Z_{in}	1800	—	4500	Ω
Output Impedance	Z_{out}	270	—	330	Ω
RCAL (150 k Ω) ⁽⁹⁾	RCAL	97	100	103	mmHg
Response Time ⁽⁵⁾ (10% to 90%)	t_R	—	1.0	—	ms
Temperature Error Band	—	0	—	85	$^\circ\text{C}$
Stability ⁽⁶⁾	—	—	± 0.5	—	$\%V_{FSS}$

MECHANICAL CHARACTERISTICS

Characteristics	Symbol	Min	Typ	Max	Unit
Weight (Case 423)	—	—	170	—	mg
Warm-Up	—	—	15	—	Sec

NOTES:

1. Measured at 6.0 Vdc excitation for 100 mmHg pressure differential. V_{FSS} and FSS are like terms representing the algebraic difference between full scale output and zero pressure offset.
2. Maximum deviation from end-point straight line fit at 0 and 300 mmHg.
3. Slope of end-point straight line fit to full scale span at 15°C and $+40^\circ\text{C}$ relative to $+25^\circ\text{C}$.
4. Slope of end-point straight line fit to zero pressure offset at 15°C and $+40^\circ\text{C}$ relative to $+25^\circ\text{C}$.
5. For a 0 to 300 mmHg pressure step change.
6. Stability is defined as the maximum difference in output at any pressure within P_{OP} and temperature within $+10^\circ\text{C}$ to $+85^\circ\text{C}$ after:
 - a. 1000 temperature cycles, -40°C to $+125^\circ\text{C}$.
 - b. 1.5 million pressure cycles, 0 to 300 mmHg.
7. Operating characteristics based on positive pressure differential relative to the vacuum side (gauge/differential).
8. Recommended voltage supply: $6 \text{ V} \pm 0.2 \text{ V}$, regulated. Sensor output is ratiometric to the voltage supply. Supply voltages above +10 V may induce additional error due to device self-heating.
9. Offset measurement with respect to the measured sensitivity when a 150k ohm resistor is connected to V_S and S+ output.

ORDERING INFORMATION

The MPXS4115A series MAP silicon pressure sensors are available shipped in sleeves.

Device Type Options	Case No.	MPX Series Order No.	Marking
Tape and Reel	423A-02		

Device	Reel Size	Tape Width	Quantity
MPX2300DT1	330 mm	24 mm	1000 pc/reel

PACKAGE DIMENSIONS

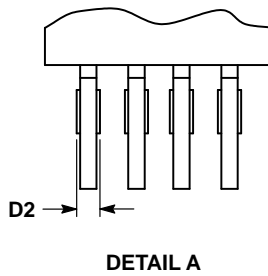
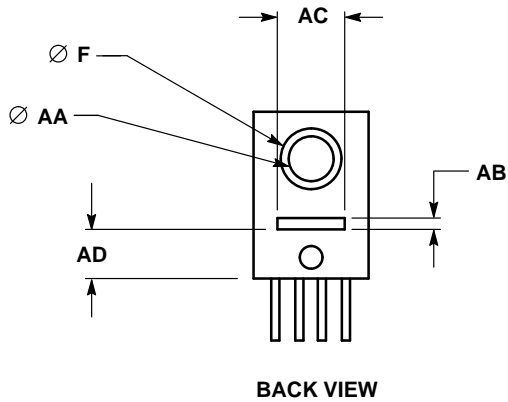
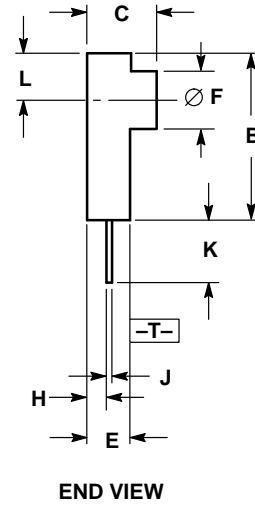
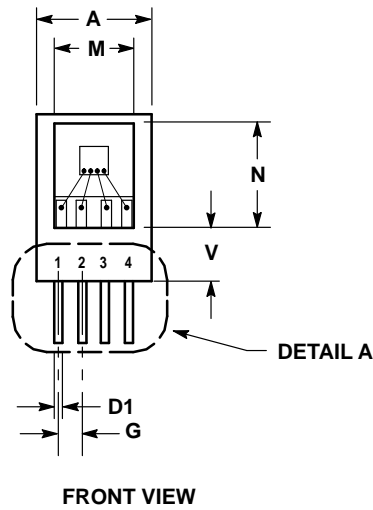

- NOTES:
 1. DIMENSIONING AND TOLERANCING PER ANSI Y14.5M, 1982.
 2. CONTROLLING DIMENSION: INCH.

DIM	INCHES		MILLIMETERS	
	MIN	MAX	MIN	MAX
A	0.240	0.260	6.10	6.60
B	0.350	0.370	8.89	9.40
C	0.140	0.150	3.56	3.81
D1	0.012	0.020	0.30	0.51
D2	0.018	0.022	0.46	0.56
E	0.088	0.102	2.24	2.59
F	0.123	0.128	3.12	3.25
G	0.045	0.055	1.14	1.40
H	0.037	0.047	0.94	1.19
J	0.007	0.011	0.18	0.28
K	0.120	0.140	3.05	3.56
L	0.095	0.105	2.41	2.67
M	0.165	0.175	4.19	4.45
N	0.223	0.239	5.66	6.07
V	0.105	0.115	2.67	2.92
AA	0.095	0.107	2.41	2.72
AB	0.015	0.035	0.38	0.89
AC	0.120	0.175	3.05	4.45
AD	0.100	0.115	2.54	2.92

- STYLE 1:
 PIN 1. V_{CC}
 2. +OUT
 3. -OUT
 4. GROUND

CASE 423A-02
 ISSUE B

Motorola reserves the right to make changes without further notice to any products herein. Motorola makes no warranty, representation or guarantee regarding the suitability of its products for any particular purpose, nor does Motorola assume any liability arising out of the application or use of any product or circuit, and specifically disclaims any and all liability, including without limitation consequential or incidental damages. "Typical" parameters which may be provided in Motorola data sheets and/or specifications can and do vary in different applications and actual performance may vary over time. All operating parameters, including "Typicals" must be validated for each customer application by customer's technical experts. Motorola does not convey any license under its patent rights nor the rights of others. Motorola products are not designed, intended, or authorized for use as components in systems intended for surgical implant into the body, or other applications intended to support or sustain life, or for any other application in which the failure of the Motorola product could create a situation where personal injury or death may occur. Should Buyer purchase or use Motorola products for any such unintended or unauthorized application, Buyer shall indemnify and hold Motorola and its officers, employees, subsidiaries, affiliates, and distributors harmless against all claims, costs, damages, and expenses, and reasonable attorney fees arising out of, directly or indirectly, any claim of personal injury or death associated with such unintended or unauthorized use, even if such claim alleges that Motorola was negligent regarding the design or manufacture of the part. Motorola and  are registered trademarks of Motorola, Inc. Motorola, Inc. is an Equal Opportunity/Affirmative Action Employer.

Mfax is a trademark of Motorola, Inc.

How to reach us:

USA/EUROPE/Locations Not Listed: Motorola Literature Distribution;
P.O. Box 5405, Denver, Colorado 80217. 303-675-2140 or 1-800-441-2447

JAPAN: Nippon Motorola Ltd.; Tatsumi-SPD-JLDC, 6F Seibu-Butsuryu-Center,
3-14-2 Tatsumi Koto-Ku, Tokyo 135, Japan. 81-3-3521-8315

Mfax™: RMFAX0@email.sps.mot.com – TOUCHTONE 602-244-6609
– US & Canada ONLY 1-800-774-1848

ASIA/PACIFIC: Motorola Semiconductors H.K. Ltd.; 8B Tai Ping Industrial Park,
51 Ting Kok Road, Tai Po, N.T., Hong Kong. 852-26629298

INTERNET: <http://motorola.com/sps>

