

800mA Low Dropout Positive Regulators Adjustable and Fixed 2.85V, 3.3V, 5V

FEATURES

- Space Saving SOT-223 Surface Mount Package
- Three-Terminal Adjustable or Fixed 2.85V, 3.3V, 5V
- Output Current of 800mA
- Operates Down to 1V Dropout
- Guaranteed Dropout Voltage at Multiple Current Levels
- 0.2% Line Regulation Max
- 0.4% Load Regulation Max

APPLICATIONS

- Active SCSI Terminators
- High Efficiency Linear Regulators
- Post Regulators for Switching Supplies
- Battery Chargers
- 5V to 3.3V Linear Regulators

DESCRIPTION

The LT1117 is a positive low dropout regulator designed to provide up to 800mA of output current. The device is available in an adjustable version and fixed output voltages of 2.85V, 3.3V and 5V. The 2.85V version is designed specifically to be used in Active Terminators for the SCSI bus. All internal circuitry is designed to operate down to 1V input to output differential. Dropout voltage is guaranteed at a maximum of 1.2V at 800mA, decreasing at lower load currents. On chip trimming adjusts the reference/output voltage to within $\pm 1\%$. Current limit is also trimmed in order to minimize the stress on both the regulator and the power source circuitry under overload conditions.

The low profile surface mount SOT-223 package allows the device to be used in applications where space is limited. The LT1117 requires a minimum of 10 μ F of output capacitance for stability. Output capacitors of this size or larger are normally included in most regulator designs.

Unlike PNP type regulators where up to 10% of the output current is wasted as quiescent current, the quiescent current of the LT1117 flows into the load, increasing efficiency.

TYPICAL APPLICATION

Active Terminator for SCSI-2 Bus

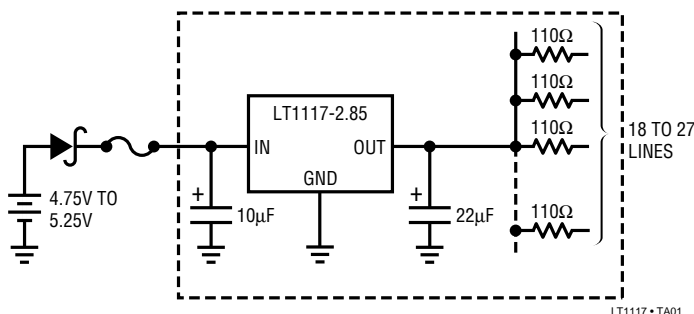

Dropout Voltage ($V_{IN} - V_{OUT}$)

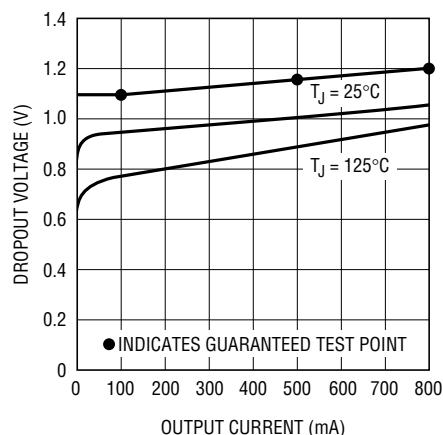

LT1117/LT1117-2.85 LT1117-3.3/LT1117-5

ABSOLUTE MAXIMUM RATINGS

Input Voltage	Operating Junction Temperature Range 0°C to 125°C
Operating Voltage	Storage Temperature Range – 65°C to 150°C
LT1117, LT1117-3.3, LT1117-5	Lead Temperature (See Soldering Methods)
LT1117-2.85		
Surge Voltage		
LT1117, LT1117-3.3, LT1117-5		

PACKAGE/ORDER INFORMATION

FRONT VIEW	ORDER PART NUMBER	FRONT VIEW	ORDER PART NUMBER
<p>ST PACKAGE 3-LEAD PLASTIC SOT-223</p> <p>$T_{J\text{MAX}} = 125^{\circ}\text{C}, \theta_{\text{JC}} = 15^{\circ}\text{C/W}$</p>	LT1117CST	<p>M PACKAGE 3-LEAD PLASTIC DD</p> <p>$T_{J\text{MAX}} = 125^{\circ}\text{C}, \theta_{\text{JC}} = 10^{\circ}\text{C/W}$</p>	LT1117CM
	LT1117CST-2.85		LT1117CM-2.85
	LT1117CST-3.3		LT1117CM-3.3
	LT1117CST-5		LT1117CM-5
PART MARKING		PART MARKING	
1117 11173		1117 11173	
11172 11175		11172 11175	

Consult factory for Industrial and Military grade parts.

ELECTRICAL CHARACTERISTICS

PARAMETER	CONDITIONS	MIN	TYP	MAX	UNITS
Reference Voltage	LT1117 $I_{\text{OUT}} = 10\text{mA}, (V_{\text{IN}} - V_{\text{OUT}}) = 2\text{V}, T_{\text{J}} = 25^{\circ}\text{C}$ $10 \leq I_{\text{OUT}} \leq 800\text{mA}, 1.4\text{V} \leq (V_{\text{IN}} - V_{\text{OUT}}) \leq 10\text{V}$	1.238	1.250	1.262	V
		1.225	1.250	1.270	V
Output Voltage	LT1117-2.85 $I_{\text{OUT}} = 10\text{mA}, V_{\text{IN}} = 4.85\text{V}, T_{\text{J}} = 25^{\circ}\text{C}$ $0 \leq I_{\text{OUT}} \leq 800\text{mA}, 4.25\text{V} \leq V_{\text{IN}} \leq 10\text{V}$ $0 \leq I_{\text{OUT}} \leq 500\text{mA}, V_{\text{IN}} = 3.95\text{V}$	2.820	2.850	2.880	V
		2.790	2.850	2.910	V
		2.790	2.850	2.910	V
	LT1117-3.3 $I_{\text{OUT}} = 10\text{mA}, V_{\text{IN}} = 5\text{V}, T_{\text{J}} = 25^{\circ}\text{C}$ $0 \leq I_{\text{OUT}} \leq 800\text{mA}, 4.75\text{V} \leq V_{\text{IN}} \leq 10\text{V}$	3.267	3.300	3.333	V
		3.235	3.300	3.365	V
	LT1117-5 $I_{\text{OUT}} = 10\text{mA}, V_{\text{IN}} = 7\text{V}, T_{\text{J}} = 25^{\circ}\text{C}$ $0 \leq I_{\text{OUT}} \leq 800\text{mA}, 6.50\text{V} \leq V_{\text{IN}} \leq 12\text{V}$	4.950	5.000	5.050	V
		4.900	5.000	5.100	V
Line Regulation	LT1117 $I_{\text{OUT}} = 10\text{mA}, 1.5\text{V} \leq V_{\text{IN}} - V_{\text{OUT}} \leq 15\text{V}$ (Note 1)		0.035	0.2	%
	LT1117-2.85 $I_{\text{OUT}} = 0\text{mA}, 4.25\text{V} \leq V_{\text{IN}} \leq 10\text{V}$ (Note 1)		1	6	mV
	LT1117-3.3 $I_{\text{OUT}} = 0\text{mA}, 4.75\text{V} \leq V_{\text{IN}} \leq 15\text{V}$ (Note 1)		1	6	mV
	LT1117-5 $I_{\text{OUT}} = 0\text{mA}, 6.5\text{V} \leq V_{\text{IN}} \leq 15\text{V}$ (Note 1)		1	10	mV
Load Regulation	LT1117 $(V_{\text{IN}} - V_{\text{OUT}}) = 3\text{V}, 10\text{mA} \leq I_{\text{OUT}} \leq 800\text{mA}$ (Note 1)		0.1	0.4	%
	LT1117-2.85 $V_{\text{IN}} = 4.25\text{V}, 0 \leq I_{\text{OUT}} \leq 800\text{mA}$ (Note 1)		1	10	mV
	LT1117-3.3 $V_{\text{IN}} = 4.75\text{V}, 0 \leq I_{\text{OUT}} \leq 800\text{mA}$ (Note 1)		1	10	mV
	LT1117-5 $V_{\text{IN}} = 6.5\text{V}, 0 \leq I_{\text{OUT}} \leq 800\text{mA}$ (Note 1)		1	15	mV
Dropout Voltage	$I_{\text{OUT}} = 100\text{mA}$ (Note 2)		1.00	1.10	V
	$I_{\text{OUT}} = 500\text{mA}$ (Note 2)		1.05	1.15	V
	$I_{\text{OUT}} = 800\text{mA}$ (Note 2)		1.10	1.20	V
Current Limit	$(V_{\text{IN}} - V_{\text{OUT}}) = 5\text{V}, T_{\text{J}} = 25^{\circ}\text{C}$	800	950	1200	mA
Minimum Load Current	LT1117 $(V_{\text{IN}} - V_{\text{OUT}}) = 15\text{V}$ (Note 3)		1.7	5	mA

ELECTRICAL CHARACTERISTICS

PARAMETER		CONDITIONS	MIN	TYP	MAX	UNITS
Quiescent Current	LT1117-2.85	$V_{IN} \leq 10V$	●	5	10	mA
	LT1117-3.3	$V_{IN} \leq 15V$	●	5	10	mA
	LT1117-5	$V_{IN} \leq 15V$	●	5	10	mA
Thermal Regulation		$T_A = 25^\circ C$, 30ms Pulse		0.01	0.1	%/W
Ripple Rejection		$f_{RIPPLE} = 120Hz$, $(V_{IN} - V_{OUT}) = 3V$, $V_{RIPPLE} = 1V_{p-p}$	●	60	75	dB
Adjust Pin Current			●	55	120	μA
Adjust Pin Current Change		$10mA \leq I_{OUT} \leq 800mA$, $1.4V \leq (V_{IN} - V_{OUT}) \leq 10V$	●	0.2	5	μA
Temperature Stability				0.5		%
Long Term Stability		$T_A = 125^\circ C$, 1000Hrs		0.3		%
RMS Output Noise		(% of V_{OUT}), $10Hz \leq f \leq 10kHz$		0.003		%
Thermal Resistance		(Junction-to-Case, at Tab)		15		$^\circ C/W$

The ● denotes specifications which apply over the full operating temperature range.

Note 1: See thermal regulation specification for changes in output voltage due to heating effects. Load regulation and line regulation are measured at a constant junction temperature by low duty cycle pulse testing.

Note 2: Dropout voltage is specified over the full output current range of the device. Dropout voltage is defined as the minimum input/output differential measured at the specified output current. Test points and limits are also shown on the Dropout Voltage curve.

Note 3: Minimum load current is defined as the minimum output current required to maintain regulation.

TYPICAL PERFORMANCE CHARACTERISTICS

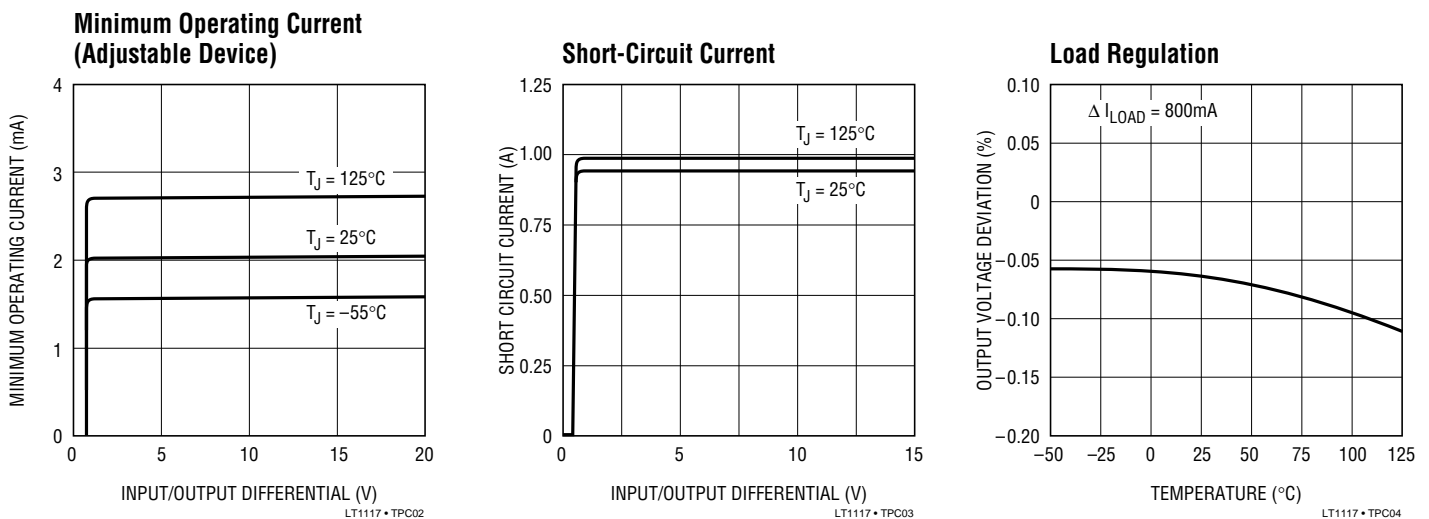

TYPICAL PERFORMANCE CHARACTERISTICS

LT1117 Ripple Rejection

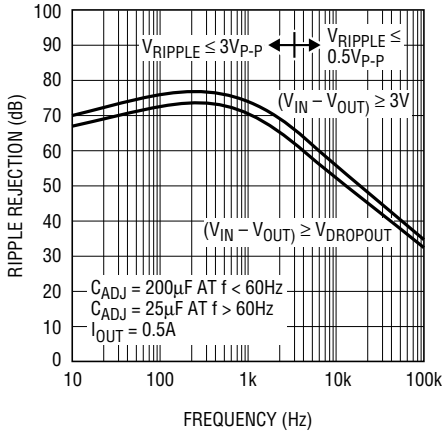

LT1117 • TPC05

LT1117 Ripple Rejection vs Current

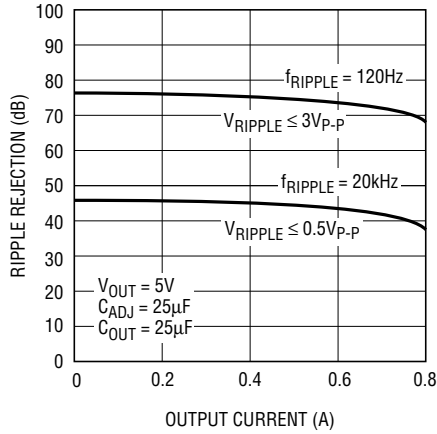

LT1117 • TPC06

Temperature Stability

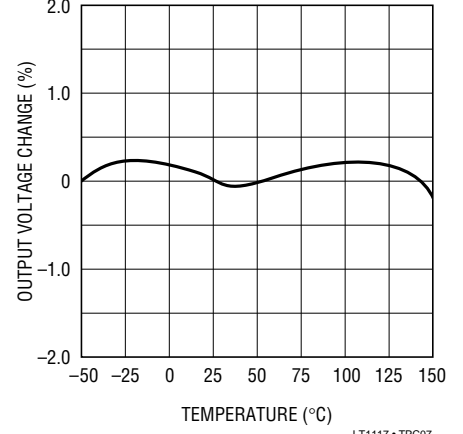

LT1117 • TPC07

Adjust Pin Current

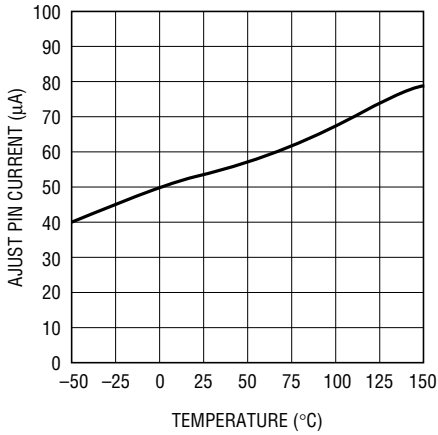

LT1117 • TPC08

LT1117-2.85 Load Transient Response

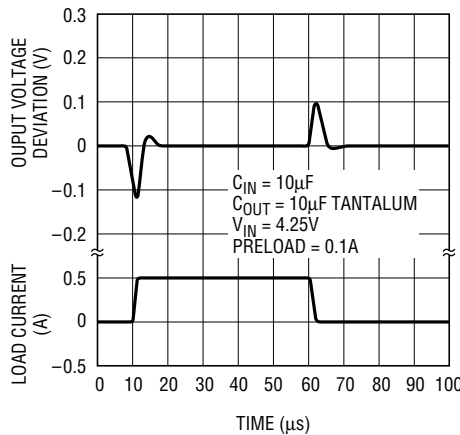

LT1117 • TPC09

LT1117-5 Load Transient Response

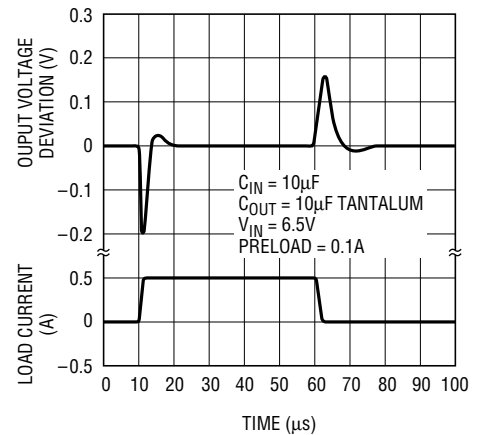

LT1117 • TPC10

LT1117-2.8 Line Transient Response

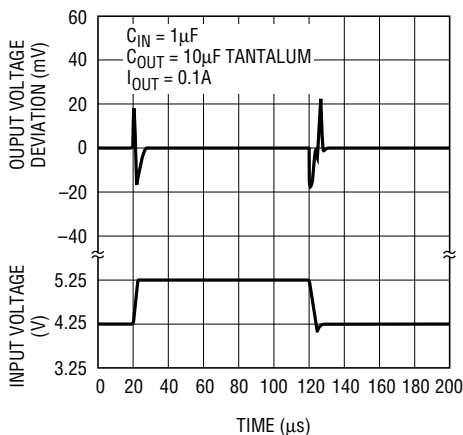

LT1117 • TPC11

LT1117-5 Line Transient Response

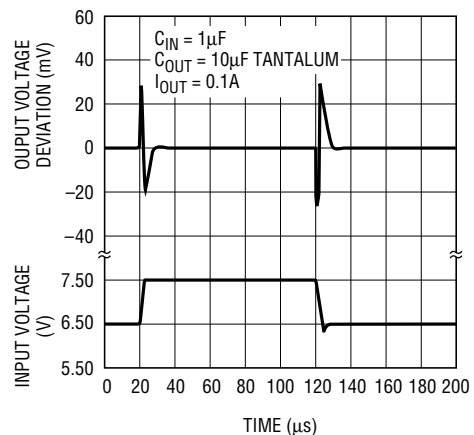

LT1117 • TPC12

BLOCK DIAGRAM

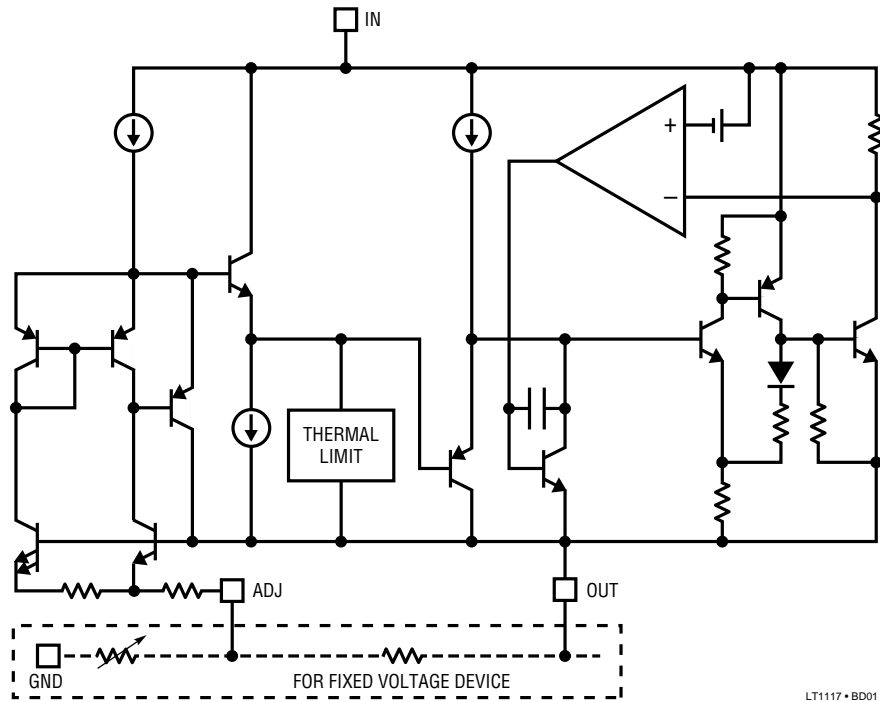

APPLICATION HINTS

The LT1117 family of three-terminal regulators are easy to use. They are protected against short circuit and thermal overloads. Thermal protection circuitry will shutdown the regulator should the junction temperature exceed 165°C at the sense point. These regulators are pin compatible with older three-terminal adjustable regulators, offer lower dropout voltage and more precise reference tolerance. Reference stability over temperature is improved over older types of regulators.

Stability

The LT1117 family of regulators requires an output capacitor as part of the device frequency compensation. A minimum of 10 μ F of tantalum or 50 μ F of aluminum electrolytic is required. The ESR of the output capacitor should be less than 0.5 Ω . Surface mount tantalum capacitors, which have very low ESR, are available from several manufacturers.

When using the LT1117 adjustable device the adjust terminal can be bypassed to improve ripple rejection.

When the adjust terminal is bypassed the required value of the output capacitor increases. The device will require an output capacitor of 22 μ F tantalum or 150 μ F aluminum electrolytic when the adjust pin is bypassed.

Normally, capacitor values on the order of 100 μ F are used in the output of many regulators to ensure good load transient response with large load current changes. Output capacitance can be increased without limit and larger values of output capacitance further improve stability and transient response.

Protection Diodes

In normal operation, the LT1117 family does not need any protection diodes. Older adjustable regulators required protection diodes between the adjust pin and the output and between the output and input to prevent over stressing the die. The internal current paths on the LT1117 adjust pin are limited by internal resistors. Therefore, even with capacitors on the adjust pin, no protection diode is needed to ensure device safety under short circuit conditions. The

APPLICATION HINTS

adjust pin can be driven, on a transient basis, $\pm 25V$ with respect to the output without any device degradation.

Diodes between input and output are not usually needed. The internal diode between the output and input pins of the device can withstand microsecond surge currents of 10A to 20A. Normal power supply cycling can not generate currents of this magnitude. Only with extremely large output capacitors, such as 1000 μF and larger, and with the input pin instantaneously shorted to ground can damage occur. A crowbar circuit at the input of the LT1117 in combination with a large output capacitor could generate currents large enough to cause damage. In this case a diode from output to input is recommended, as shown in Figure 1.

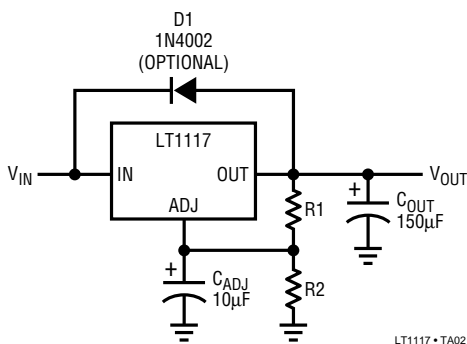

Figure 1.

Output Voltage

The LT1117 develops a 1.25V reference voltage between the output and the adjust terminal (see Figure 2). By placing a resistor between these two terminals, a constant current is caused to flow through R1 and down through R2

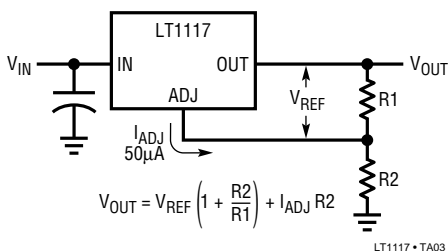

Figure 2. Basic Adjustable Regulator

to set the overall output voltage. Normally this current is chosen to be the specified minimum load current of 10mA. Because I_{ADJ} is very small and constant when compared to the current through R1, it represents a small error and can usually be ignored. For fixed voltage devices R1 and R2 are included in the device.

Load Regulation

Because the LT1117 is a three-terminal device, it is not possible to provide true remote load sensing. Load regulation will be limited by the resistance of the wire connecting the regulator to the load. The data sheet specification for load regulation is measured at the output pin of the device. Negative side sensing is a true Kelvin connection, with the bottom of the output divider returned to the negative side of the load. Although it may not be immediately obvious, best load regulation is obtained when the top of the resistor divider (R1) is returned directly to the output pin of the device, not to the load. This is illustrated in Figure 3. Connected as shown, R_P is not multiplied by the divider ratio. If R1 were connected to the load, the effective resistance between the regulator and the load would be:

$$R_P \times \frac{R2 + R1}{R1}, R_P = \text{Parasitic Line Resistance}$$

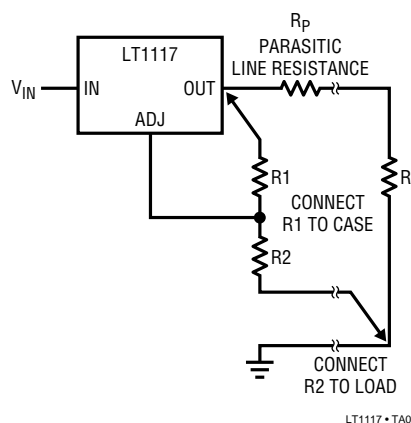

Figure 3. Connections for Best Load Regulation

For fixed voltage devices the top of R1 is internally Kelvin connected, and the ground pin can be used for negative side sensing.

APPLICATION HINTS

Thermal Considerations

LT1117 series regulators have internal thermal limiting circuitry designed to protect the device during overload conditions. For continuous normal load conditions however, the maximum junction temperature rating of 125°C must not be exceeded.

It is important to give careful consideration to all sources of thermal resistance from junction to ambient. For the SOT-223 package, which is designed to be surface mounted, additional heat sources mounted near the device must also be considered. Heat sinking is accomplished using the heat spreading capability of the PC board and its copper traces. The thermal resistance of the LT1117 is 15°C/W from the junction to the tab. Thermal resistances from tab to ambient can be as low as 30°C/W. The total thermal resistance from junction to ambient can be as low as 45°C/W. This requires a reasonable sized PC board with at least one layer of copper to spread the heat across the board and couple it into the surrounding air.

Experiments have shown that the heat spreading copper layer does not need to be electrically connected to the tab of the device. The PC material can be very effective at transmitting heat between the pad area, attached to the tab of the device, and a ground plane layer either inside or on the opposite side of the board. Although the actual thermal resistance of the PC material is high, the Length/Area ratio of the thermal resistor between layers is small. The data in Table 1 was taken using 1/16" FR-4 board with 1oz. copper foil. It can be used as a rough guideline in estimating thermal resistance.

Table 1.

COPPER AREA		BOARD AREA	THERMAL RESISTANCE (JUNCTION-TO-AMBIENT)
TOPSIDE*	BACKSIDE		
2500 Sq. mm	2500 Sq. mm	2500 Sq. mm	45°C/W
1000 Sq. mm	2500 Sq. mm	2500 Sq. mm	45°C/W
225 Sq. mm	2500 Sq. mm	2500 Sq. mm	53°C/W
100 Sq. mm	2500 Sq. mm	2500 Sq. mm	59°C/W
1000 Sq. mm	1000 Sq. mm	1000 Sq. mm	52°C/W
1000 Sq. mm	0	1000 Sq. mm	55°C/W

* Tab of device attached to topside copper

The thermal resistance for each application will be affected by thermal interactions with other components on the board. Some experimentation will be necessary to determine the actual value.

The power dissipation of the LT1117 is equal to:

$$P_D = (V_{IN} - V_{OUT})(I_{OUT})$$

Maximum junction temperature will be equal to:

$$T_J = T_{A(MAX)} + P_D(\text{Thermal Resistance (junction-to-ambient)})$$

Maximum junction temperature must not exceed 125°C.

Ripple Rejection

The curves for Ripple Rejection were generated using an adjustable device with the adjust pin bypassed. These curves will hold true for all values of output voltage. For proper bypassing, and ripple rejection approaching the values shown, the impedance of the adjust pin capacitor, at the ripple frequency, should be < R1. R1 is normally in the range of 100Ω-200Ω. The size of the required adjust pin capacitor is a function of the input ripple frequency. At 120Hz, with R1=100Ω, the adjust pin capacitor should be > 13μF. At 10kHz only 0.16μF is needed.

For fixed voltage devices, and adjustable devices without an adjust pin capacitor, the output ripple will increase as the ratio of the output voltage to the reference voltage (V_{OUT}/V_{REF}). For example, with the output voltage equal to 5V, the output ripple will be increased by the ratio of 5V/1.25V. It will increase by a factor of four. Ripple rejection will be degraded by 12dB from the value shown on the curve.

TYPICAL APPLICATIONS

1.2V to 10V Adjustable Regulator

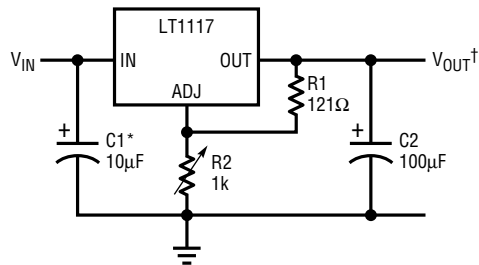

* NEEDED IF DEVICE IS FAR FROM FILTER CAPACITORS

$$V_{OUT} = 1.25V \left(1 + \frac{R2}{R1}\right)$$

LT1117 • TA05

5V Regulator with Shutdown

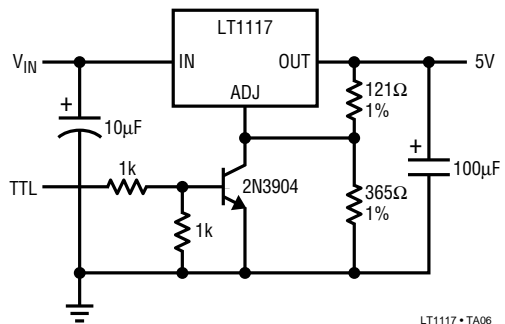

LT1117 • TA06

Remote Sensing

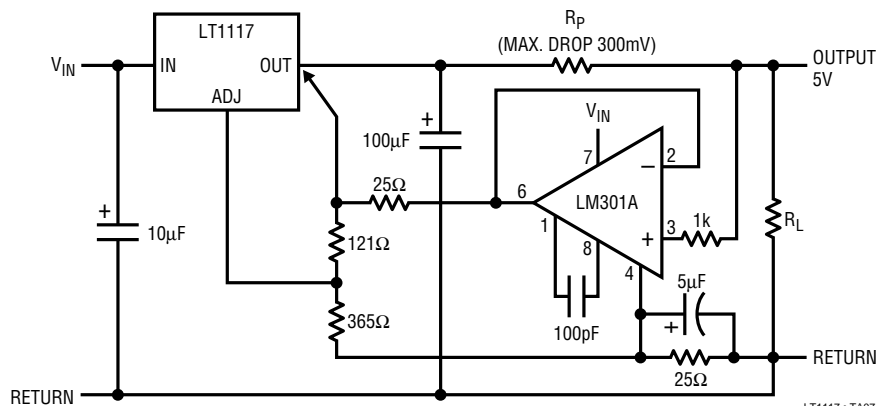

LT1117 • TA07

Adjusting Output Voltage of Fixed Regulators

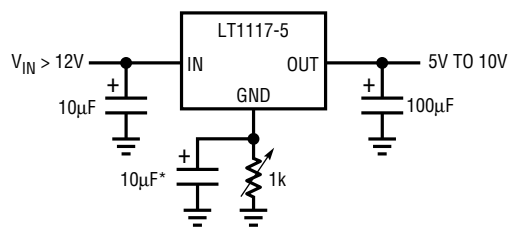

* OPTIONAL IMPROVES RIPPLE REJECTION

LT1117 • TA08

Regulator with Reference

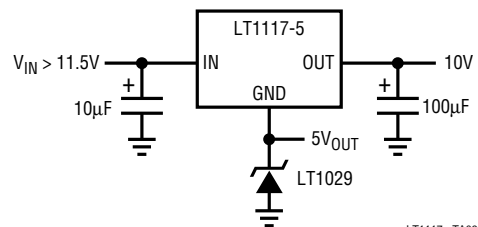

LT1117 • TA09

TYPICAL APPLICATIONS

Battery Charger

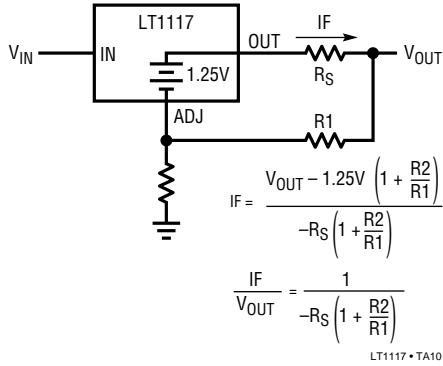

Battery Backed Up Regulated Supply

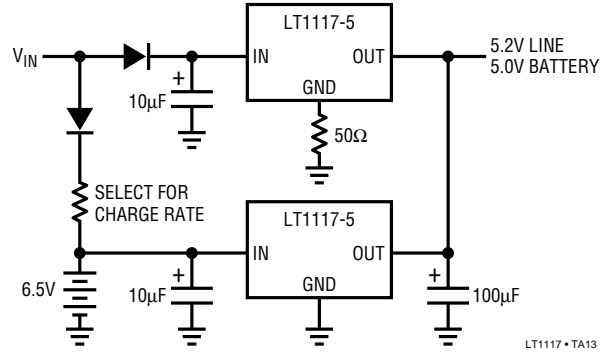

Improving Ripple Rejection

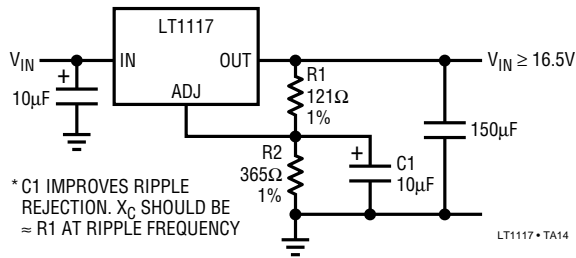

Automatic Light Control

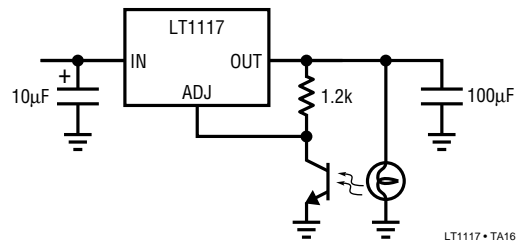

High Efficiency Dual Supply

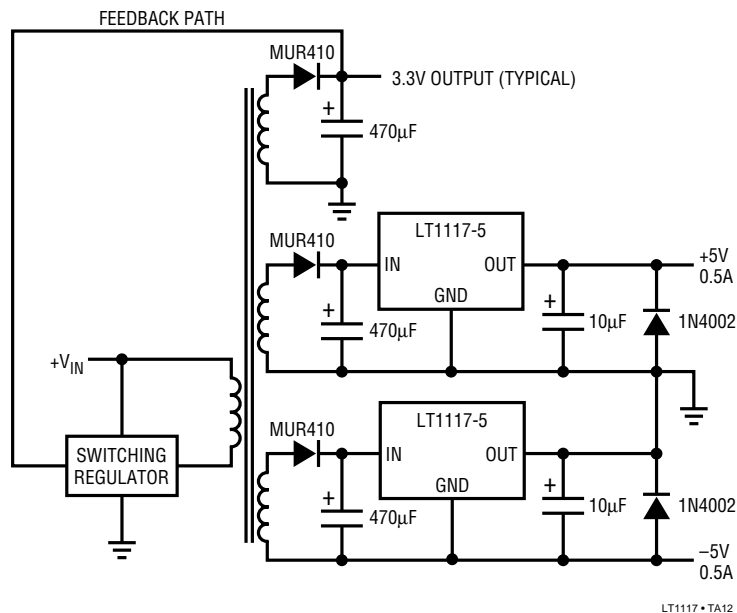

TYPICAL APPLICATIONS

High Efficiency Dual Linear Supply

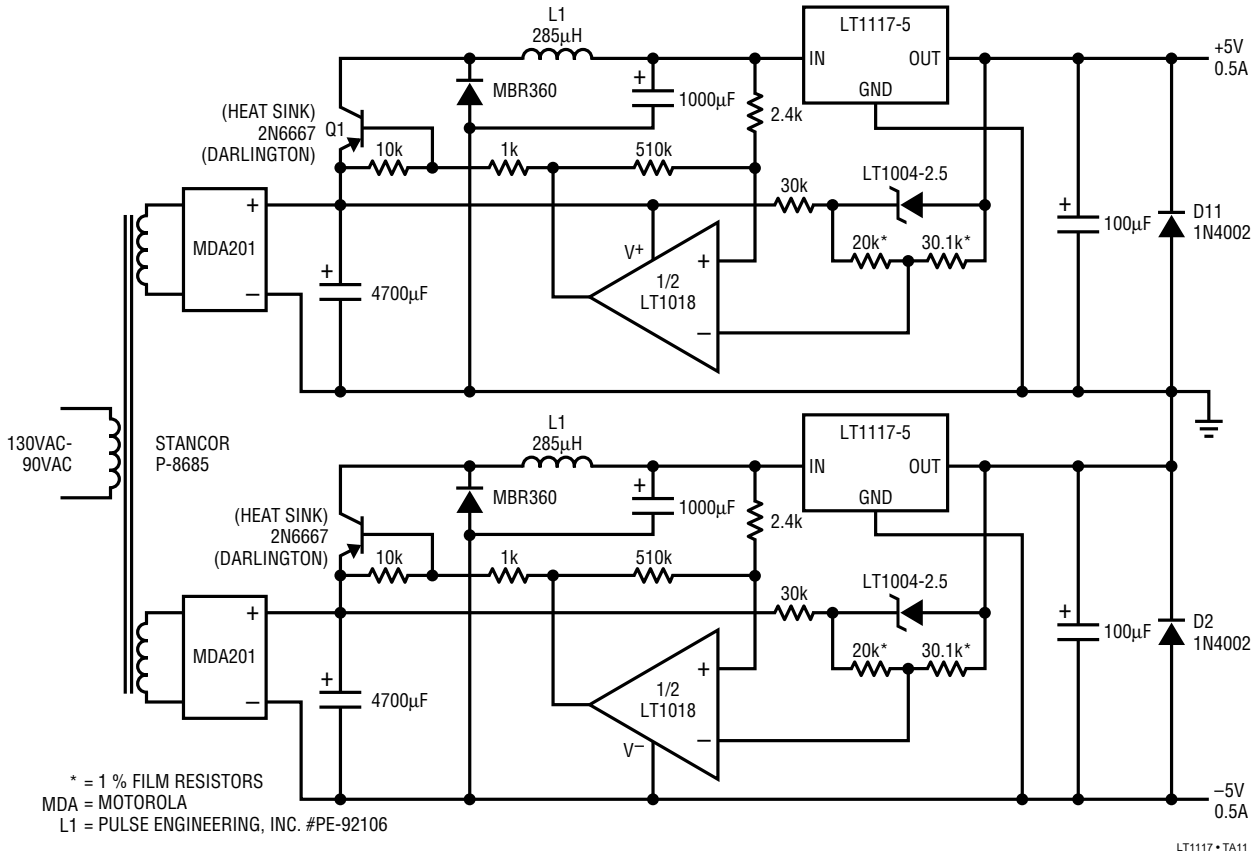

Low Dropout Negative Supply

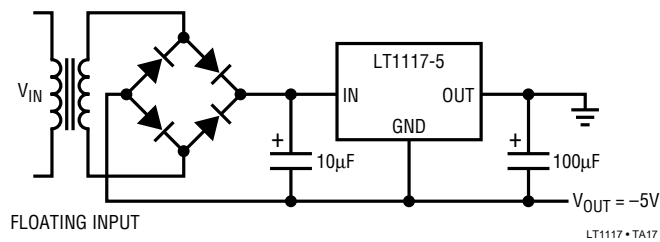

TYPICAL APPLICATIONS

High Efficiency Regulator

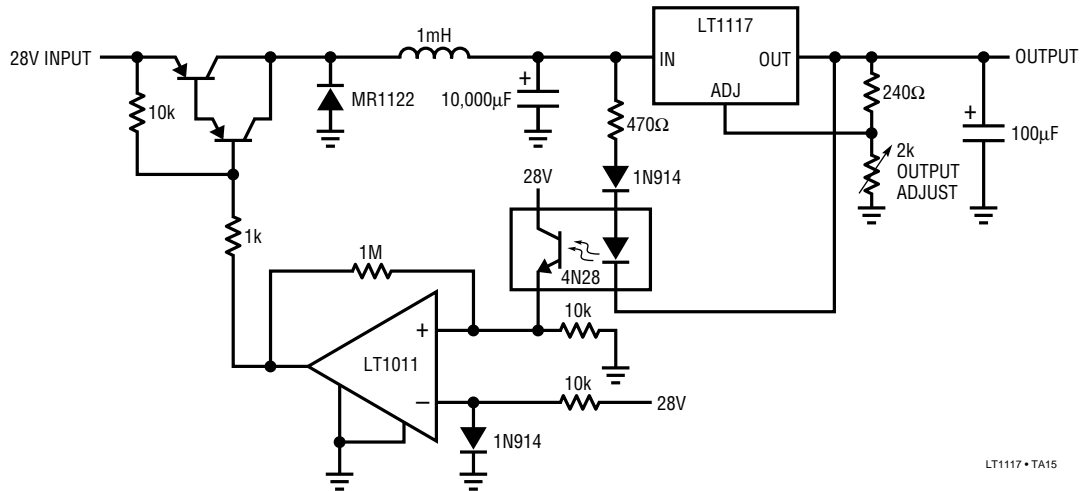

LT1117 • TA15

SOLDERING METHODS

The SOT-223 is manufactured with gull wing leadform for surface mount applications. The leads and heatsink are solder plated and allow easy soldering using non-active or mildly active fluxes. The package is constructed with three leads exiting one side of the package and one heatsink exiting the other side, and the die attached to the heatsink internally.

The recommended methods of soldering SOT-223 are: vapor phase reflow and infrared reflow with preheat of component to within 65°C of the solder temperature. Hand soldering and wave soldering are not recommended since these methods can easily damage the part with excessive thermal gradients across the package.

Care must be exercised during surface mount to minimize large (> 30°C per second) thermal shock to the package.

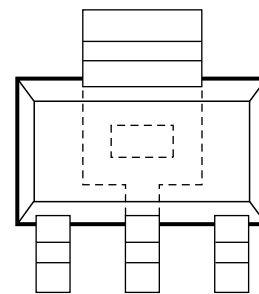

LT1117 • TA18

PACKAGE DESCRIPTION Dimensions in inches (millimeters) unless otherwise noted.

**M Package
 3-Lead Plastic DD**

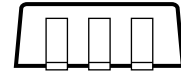
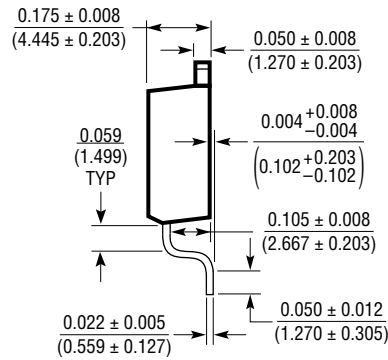
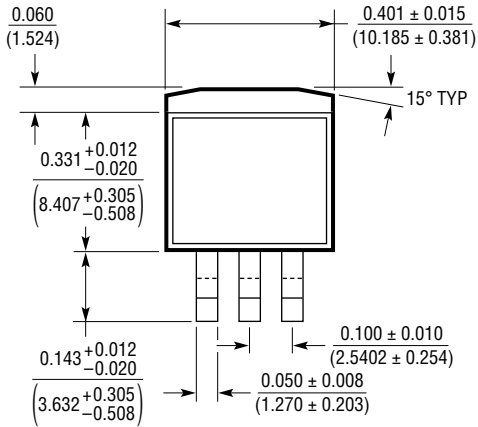

DD3 0693

**ST Package
 3-Lead Plastic SOT-223**

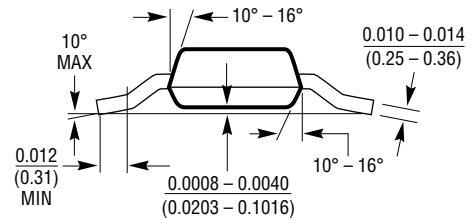
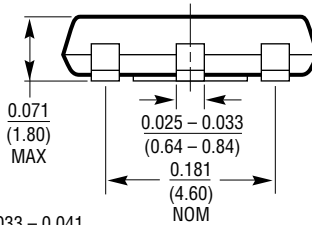
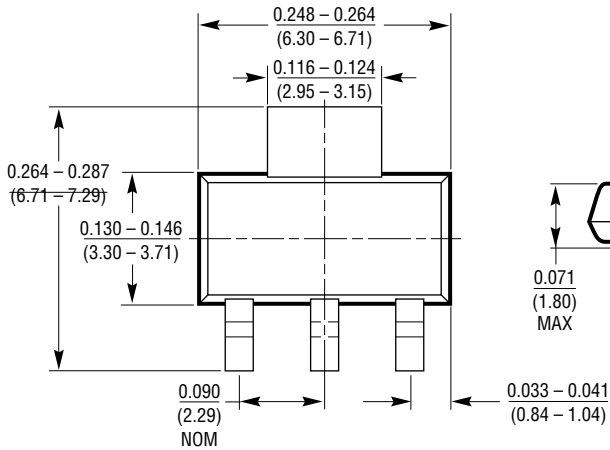

SOT233 0793