

Data Sheet

Features

- Output voltage $5\text{ V} \pm 2\%$
- 150 mA Output current
- Extreme low current consumption typical $65\ \mu\text{A}$ in ON state
- Inhibit function: Below $1\ \mu\text{A}$ current consumption in off mode
- Early warning
- Reset output low down to $V_Q = 1\text{ V}$
- Adjustable reset threshold
- Overtemperature protection
- Reverse polarity proof
- Wide temperature range

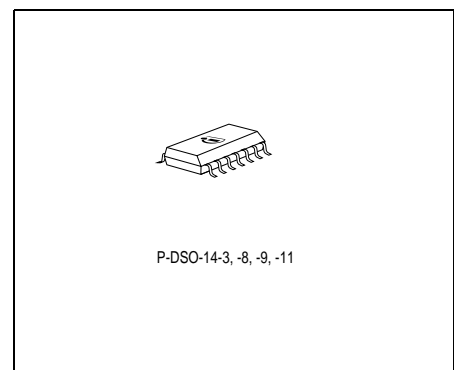
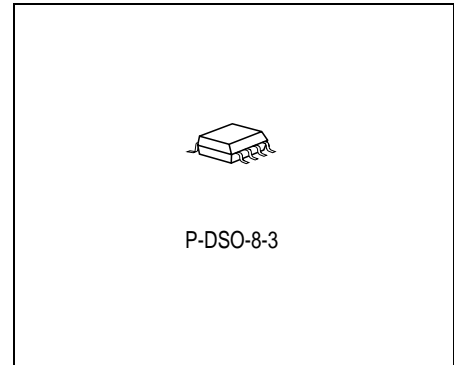

Type	Ordering Code	Package
▼ TLE 4299 G	Q67006-A9417	P-DSO-8-3 (SMD)
▼ TLE 4299 GM	Q67006-A9441	P-DSO-14-8 (SMD)

▼ New type

Functional Description

The TLE 4299 is a monolithic voltage regulator with fixed 5-V output, supplying loads up to 150 mA. It is especially designed for applications that may not be powered down while the motor is off. It only needs a quiescent current of typical $65\ \mu\text{A}$. In addition the TLE 4299 GM includes an inhibit function. When the inhibit signal is removed, the device is switched off and the quiescent current is less than $1\ \mu\text{A}$. To achieve proper operation of the μ -controller, the device supplies a reset signal. The reset delay time is selected application-specific by an external delay capacitor. The reset threshold is adjustable. An early warning signal supervises the voltage at pin SI. The TLE 4299 is pin-compatible to the TLE 4269 and functional similar with the additional inhibit function. The TLE 4299 is designed to supply microcontroller systems even under automotive environment conditions. Therefore it is protected against overload, short circuit and over temperature.

Circuit Description

The TLE 4299 is a PNP based very low drop linear voltage regulator. It regulates the output voltage to $V_Q = 5\text{ V}$ for an input voltage range of $5.5\text{ V} \leq V_I \leq 45\text{ V}$. The control circuit protects the device against potential damage caused by overcurrent and overtemperature.

The internal control circuit achieves a 5 V output voltage with a tolerance of $\pm 2\%$.

The device includes a power on reset and an under voltage reset function with adjustable reset delay time and adjustable reset switching threshold as well as a sense control/early warning function. The device includes an inhibit function to disable it when the ECU is not used for example while the motor is off.

The reset logic compares the output voltage V_Q to an internal threshold. If the output voltage drops below this level, the external reset delay capacitor C_D is discharged. When V_D is lower than V_{LD} , the reset output RO is switched Low. If the output voltage drop is very short, the V_{LD} level is not reached and no reset-signal is asserted. This feature avoids resets at short negative spikes at the output voltage e.g. caused by load changes.

As soon as the output voltage is more positive than the reset threshold, the delay capacitor is charged with constant current. When the voltage reaches V_{UD} the reset output RO is set High again.

The reset threshold is either the internal defined V_{RT} voltage (typical 4.6 V) or can be lowered by a voltage level at the RADJ input down to 3.5 V. The reset delay time and the reset reaction time are defined by the external capacitor C_D . The reset function is active down to $V_I = 1\text{ V}$.

In addition to the normal reset function, the device gives an early warning. When the SI voltage drops below $V_{SI,low}$, the device asserts the SI output Low to indicate the logic and the μ -processor that this voltage has dropped. The sense function uses a hysteresis: When the SI-voltage reaches the $V_{SI,high}$ level, SO is set high again. This feature can be used as an early warning function to notify the μ -controller about a battery voltage drop and a possible reset in a short time. Of course also any other voltage can be observed by this feature.

The user defines the threshold by the resistor-values R_{SI1} and R_{SI2} .

For the exact timing and calculation of the reset and sense timing and thresholds, please refer to the application section.

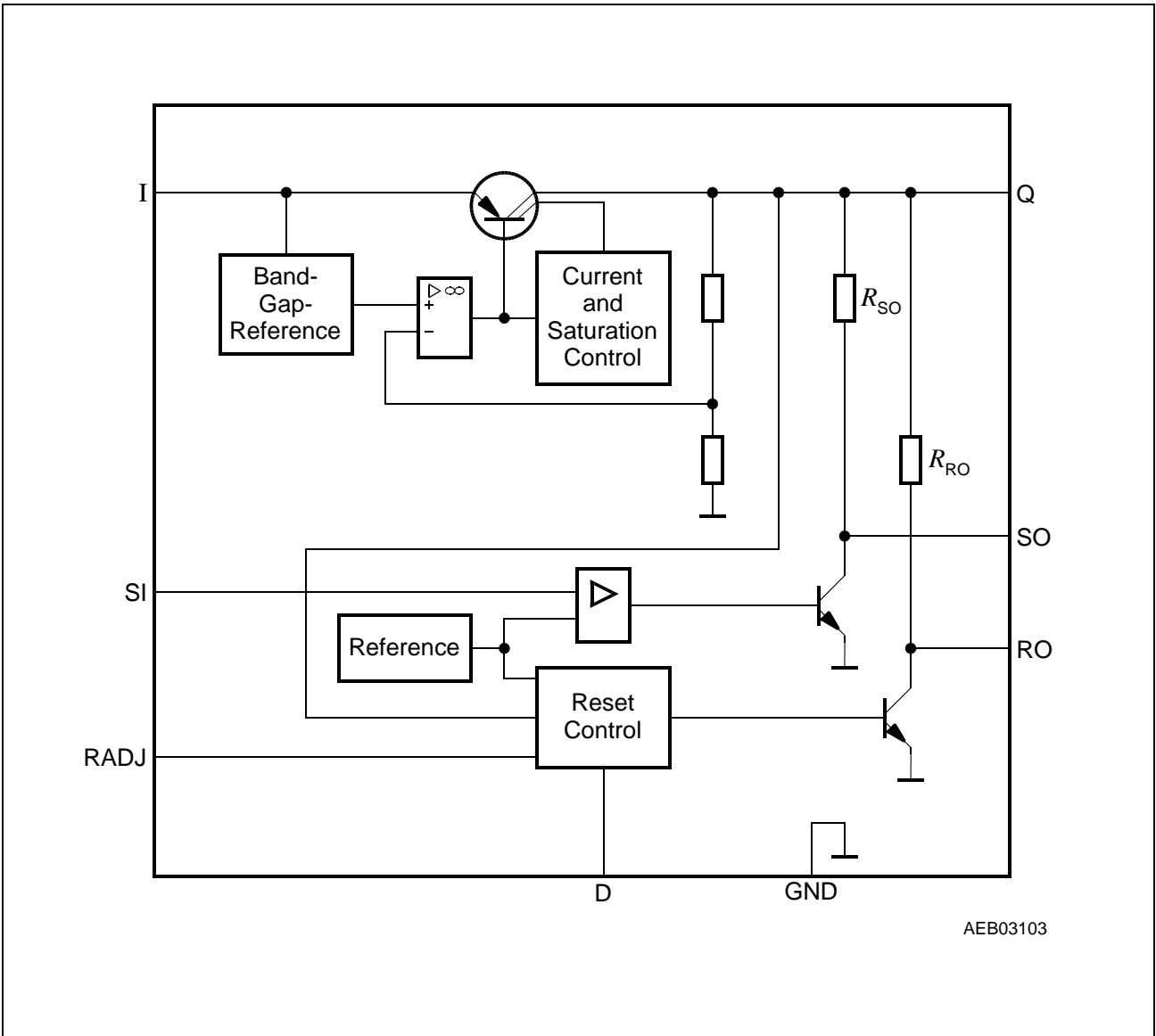

Figure 1 Block Diagram TLE 4299 G

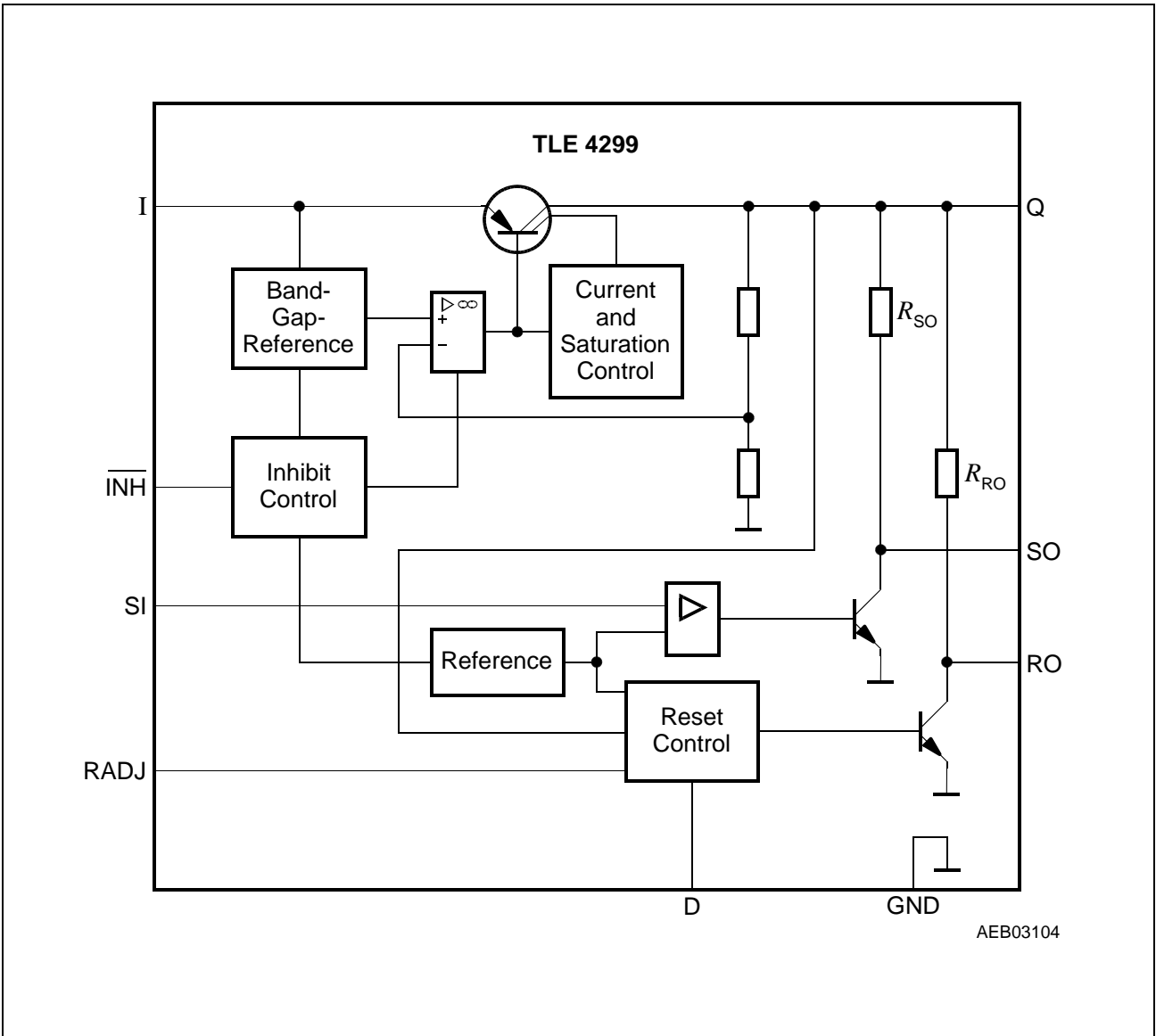

Figure 2 Block Diagram TLE 4299 GM

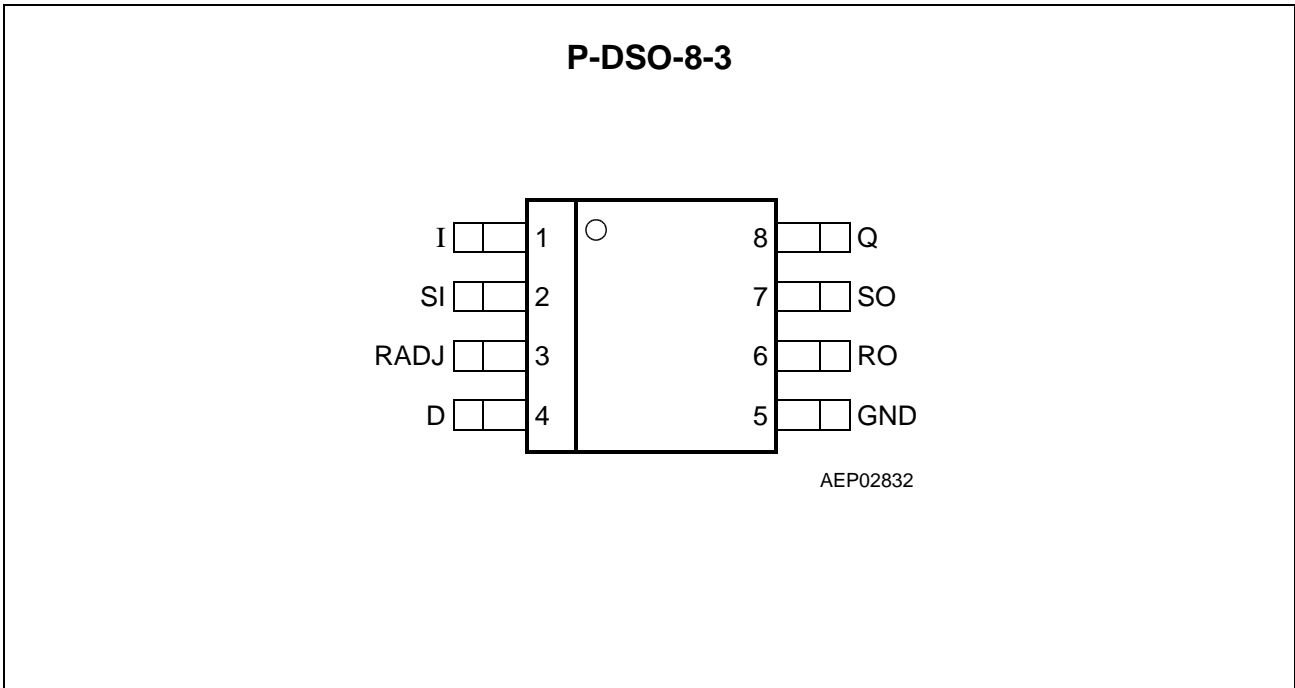

Figure 3 Pin Configuration (top view)

Pin Definitions and Functions (TLE 4299 G)

Pin No.	Symbol	Function
1	I	Input ; block directly to GND on the IC with a ceramic capacitor.
2	SI	Sense Input ; if not needed connect to Q.
3	RADJ	Reset Threshold ; if not needed connect to GND.
4	D	Reset Delay ; to select delay time, connect to GND via external capacitor.
5	GND	Ground
6	RO	Reset Output ; the open-collector output is internally linked to Q via a 20 kΩ pull-up resistor. Keep open, if the pin is not needed.
7	SO	Sense Output ; the open-collector output is internally linked to the output via a 20 kΩ pull-up resistor. Keep open, if the pin is not needed.
8	Q	5-V Output ; connect to GND with a 22 μF capacitor, ESR < 5 Ω.

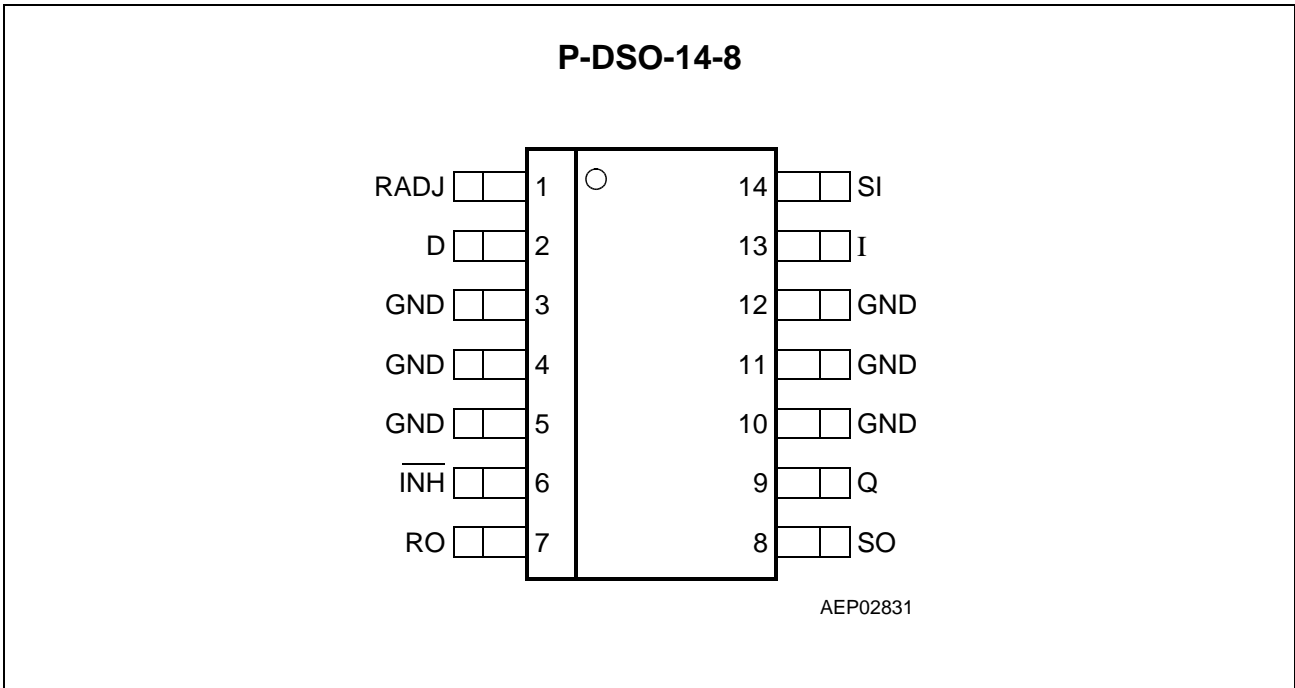

Figure 4 Pin Configuration (top view)

Pin Definitions and Functions (TLE 4299 GM)

Pin No.	Symbol	Function
1	RADJ	Reset Threshold ; if not needed connect to GND.
2	D	Reset Delay ; connect to GND via external delay capacitor for setting delay time.
3, 4, 5	GND	Ground
6	$\overline{\text{INH}}$	Inhibit ; If not needed connect to input pin I; a high signal switches the regulator ON.
7	RO	Reset Output ; open-collector output, internally connected to Q via a pull-up resistor of 20 k Ω . Keep open, if the pin is not needed.
8	SO	Sense Output ; open-collector output, internally connected to Q via a 20 k Ω pull-up resistor. Keep open, if the pin is not needed.
9	Q	5-V Output ; connect to GND with a 22 μF capacitor, ESR < 5 Ω .
10, 11, 12	GND	Ground
13	I	Input ; block to GND directly at the IC by a ceramic capacitor.
14	SI	Sense Input ; if not needed connect to Q.

Absolute Maximum Ratings

$T_j = -40$ to 150 °C

Parameter	Symbol	Limit Values		Unit	Notes
		min.	max.		

Input I

Input voltage	V_I	- 40	45	V	-
---------------	-------	------	----	---	---

Inhibit Input \overline{INH}

Input voltage	$V_{\overline{INH}}$	- 40	45	V	-
---------------	----------------------	------	----	---	---

Sense Input SI

Input voltage	V_{SI}	- 0.3	45	V	-
Input current	I_{SI}	1	1	mA	-

Reset Threshold RADJ

Voltage	V_{RE}	- 0.3	7	V	-
Current	I_{RE}	- 10	10	mA	-

Reset Delay D

Voltage	V_D	- 0.3	7	V	-
---------	-------	-------	---	---	---

Reset Output RO

Voltage	V_R	- 0.3	7	V	-
---------	-------	-------	---	---	---

Sense Output SO

Voltage	V_{SO}	- 0.3	7	V	-
---------	----------	-------	---	---	---

5-V Output Q

Output voltage	V_Q	- 0.3	7	V	-
Output current	I_Q	- 5	-	mA	-

Absolute Maximum Ratings (cont'd)

$$T_j = -40 \text{ to } 150 \text{ } ^\circ\text{C}$$

Parameter	Symbol	Limit Values		Unit	Notes
		min.	max.		

Temperature

Junction temperature	T_j	–	150	$^\circ\text{C}$	–
Storage temperature	T_{Stg}	– 50	150	$^\circ\text{C}$	–

Operating Range

Input voltage	V_I	–	45	V	–
Junction temperature	T_j	– 40	150	$^\circ\text{C}$	–

Thermal Data

Junction-ambient	R_{thja}	–	200	K/W	P-DSO-8-3
			70	K/W	P-DSO-14-8
Junction-pin	R_{thjp}	–	60	K/W	P-DSO-8-3
			30	K/W	P-DSO-14-8 ¹⁾

¹⁾ Measured to pin 4.

Note: Stresses above those listed here may cause permanent damage to the device. Exposure to absolute maximum rating conditions for extended periods may affect device reliability.

In the operating range, the functions given in the circuit description are fulfilled.

Characteristics
 $V_I = 13.5 \text{ V}; T_j = -40 \text{ }^\circ\text{C} < T_j < 150 \text{ }^\circ\text{C}$

Parameter	Symbol	Limit Values			Unit	Measuring Condition
		min.	typ.	max.		
Output voltage	V_Q	4.90	5.00	5.10	V	$1 \text{ mA} \leq I_Q \leq 100 \text{ mA};$ $6 \text{ V} \leq V_I \leq 16 \text{ V}$
Output voltage	V_Q	4.85	5.00	5.15	V	$I_Q \leq 150 \text{ mA};$ $6 \text{ V} \leq V_I \leq 16 \text{ V}$
Current limit	I_Q	250	400	500	mA	–
Current consumption; $I_q = I_I - I_Q$	I_q	–	65	105	μA	Inhibit ON; $I_Q \leq 1 \text{ mA}, T_j < 85 \text{ }^\circ\text{C}$
Current consumption; $I_q = I_I - I_Q$	I_q	–	65	100	μA	Inhibit ON; $I_Q \leq 1 \text{ mA}, T_j = 25 \text{ }^\circ\text{C}$
Current consumption; $I_q = I_I - I_Q$	I_q	–	170	500	μA	Inhibit ON; $I_Q = 10 \text{ mA}$
Current consumption; $I_q = I_I - I_Q$	I_q	–	0.7	2	mA	Inhibit ON; $I_Q = 50 \text{ mA}$
Current consumption; $I_q = I_I - I_Q$	I_q	–	–	1	μA	$V_{\text{INH}} = 0 \text{ V};$ $T_j = 25 \text{ }^\circ\text{C}$
Drop voltage	V_{dr}	–	0.22	0.5	V	$I_Q = 100 \text{ mA}^{1)}$
Load regulation	ΔV_Q	–	5	30	mV	$I_Q = 1 \text{ mA to } 100 \text{ mA}$
Line regulation	ΔV_Q	–	10	25	mV	$V_I = 6 \text{ V to } 28 \text{ V};$ $I_Q = 1 \text{ mA}$
Power Supply Ripple rejection	$PSRR$	–	66	–	dB	$f_r = 100 \text{ Hz}; V_r = 1 V_{\text{SS}};$ $I_Q = 100 \text{ mA}$

Inhibit (TLE 4299 GM only)

Inhibit OFF voltage range	$V_{\text{INH OFF}}$	–	–	0.8	V	TLE 4299 GM; V_Q off
Inhibit ON voltage range	$V_{\text{INH ON}}$	3.5	–	–	V	TLE 4299 GM; V_Q on
High input current	$I_{\text{INH ON}}$	–	3	5	μA	TLE 4299 GM; $V_{\text{INH}} = 5 \text{ V}$
Low input current	$I_{\text{INH OFF}}$	–	0.5	2	μA	TLE 4299 GM; $V_{\text{INH}} = 0 \text{ V}$

¹⁾ Drop voltage = $V_I - V_Q$ (measured when the output voltage has dropped 100 mV from the nominal value obtained at 13.5 V input.)

Characteristics (cont'd)
 $V_i = 13.5 \text{ V}; T_j = -40 \text{ }^\circ\text{C} < T_j < 150 \text{ }^\circ\text{C}$

Parameter	Symbol	Limit Values			Unit	Measuring Condition
		min.	typ.	max.		

Reset Generator

Switching threshold	V_{rt}	4.50	4.60	4.80	V	–
Reset pull up	R_{RO}	10	20	40	k Ω	–
Reset low voltage	V_R	–	0.17	0.40	V	$V_Q < 4.5 \text{ V};$ internal $R_{RO};$ $I_R = 1 \text{ mA}$
External reset pull up	$V_{R \text{ ext}}$	5.6	–	–	k Ω	Pull up resistor to Q
Delay switching threshold	V_{DT}	1.5	1.85	2.2	V	–
Switching threshold	V_{ST}	0.40	0.50	0.60	V	–
Reset delay low voltage	V_D	–	–	0.1	V	$V_Q < V_{RT}$
Charge current	I_{ch}	4.0	8.0	12.0	μA	$V_D = 1 \text{ V}$
Reset delay time	t_d	17	28	35	ms	$C_D = 100 \text{ nF}$
Reset reaction time	t_{rr}	0.5	1.2	3.0	μs	$C_D = 100 \text{ nF}$
Reset adjust switching threshold	$V_{RADJ TH}$	1.26	1.36	1.44	V	$V_Q > 3.5 \text{ V}$

Input Voltage Sense

Sense threshold high	$V_{SI \text{ high}}$	1.34	1.45	1.54	V	–
Sense threshold low	$V_{SI \text{ low}}$	1.26	1.36	1.44	V	–
Sense input switching hysteresis	$V_{SI \text{ HYST}}$	50	90	130	mV	$V_{SI \text{ HYST}} = V_{SI \text{ high}} - V_{SI \text{ low}}$
Sense output low voltage	$V_{SO \text{ low}}$	–	0.1	0.4	V	$V_{SI} < 1.20 \text{ V}; V_i > 4.2 \text{ V};$ $I_{SO} = 0$
External SO pull up resistor	$R_{SO \text{ ext}}$	5.6	–	–	k Ω	–
Sense pull up	R_{SO}	10	20	40	k Ω	–
Sense input current	I_{SI}	– 1	0.1	1	μA	–
Sense high reaction time	$t_{pd \text{ SO LH}}$	–	2.4	2.9	μs	–
Sense low reaction time	$t_{pd \text{ SO HL}}$	–	1.7	2.1	μs	–

Note: The listed characteristics are ensured over the operating range of the integrated circuit. Typical characteristics specify mean values expected over the production spread. If not otherwise specified, typical characteristics apply at $T_A = 25^\circ\text{C}$ and the given supply voltage.

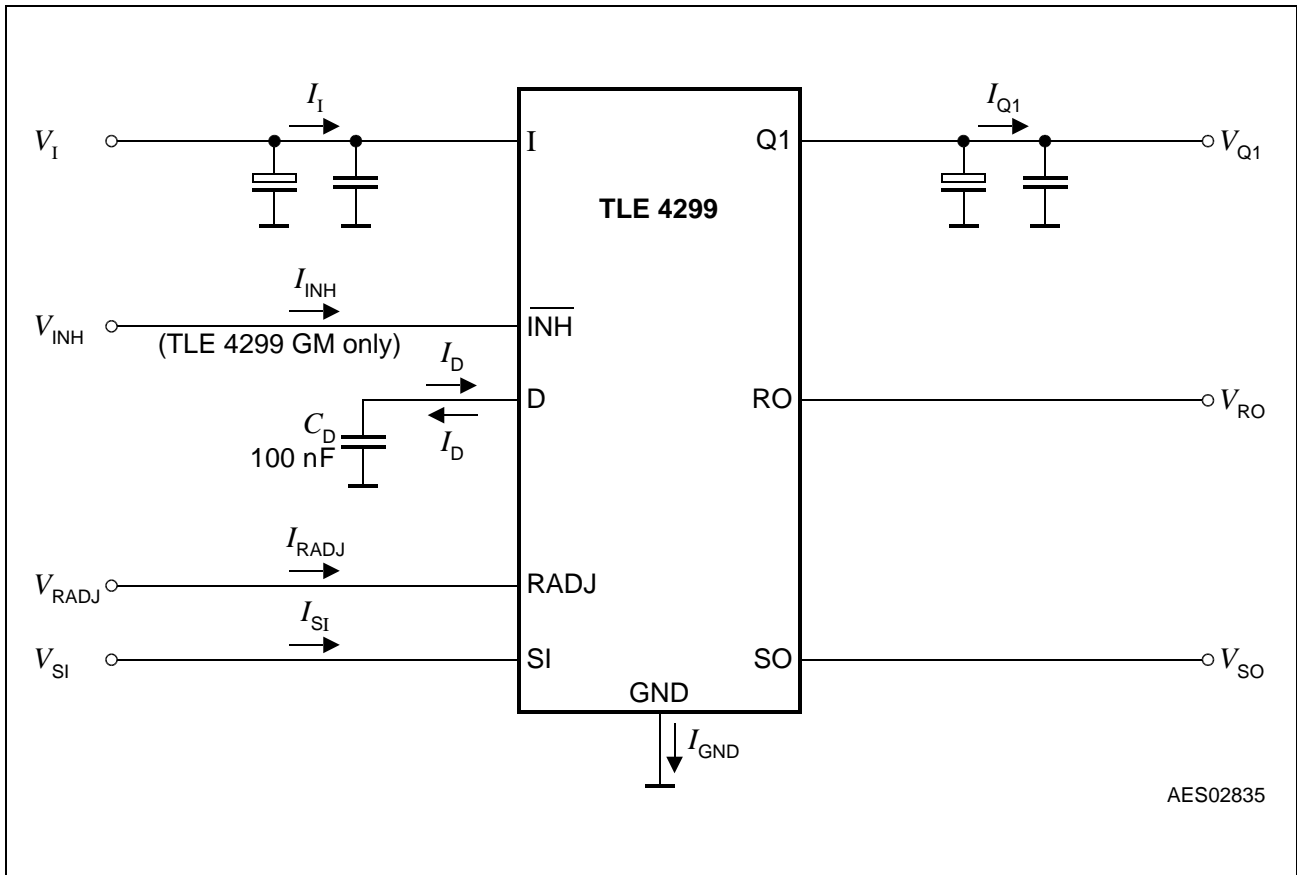

Figure 5 Measurement Circuit

Application Information

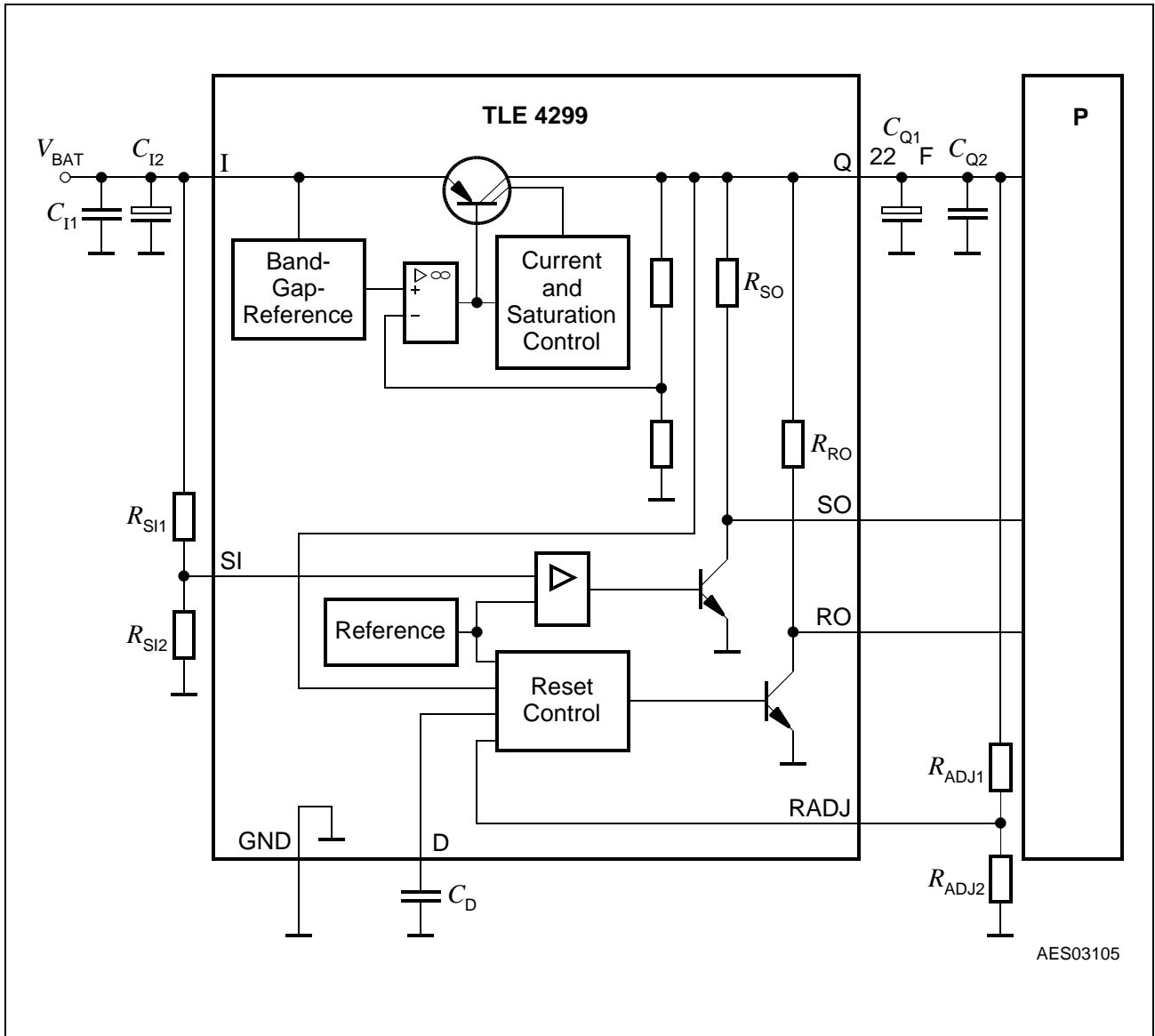

Figure 6 Application Diagram TLE 4299 G

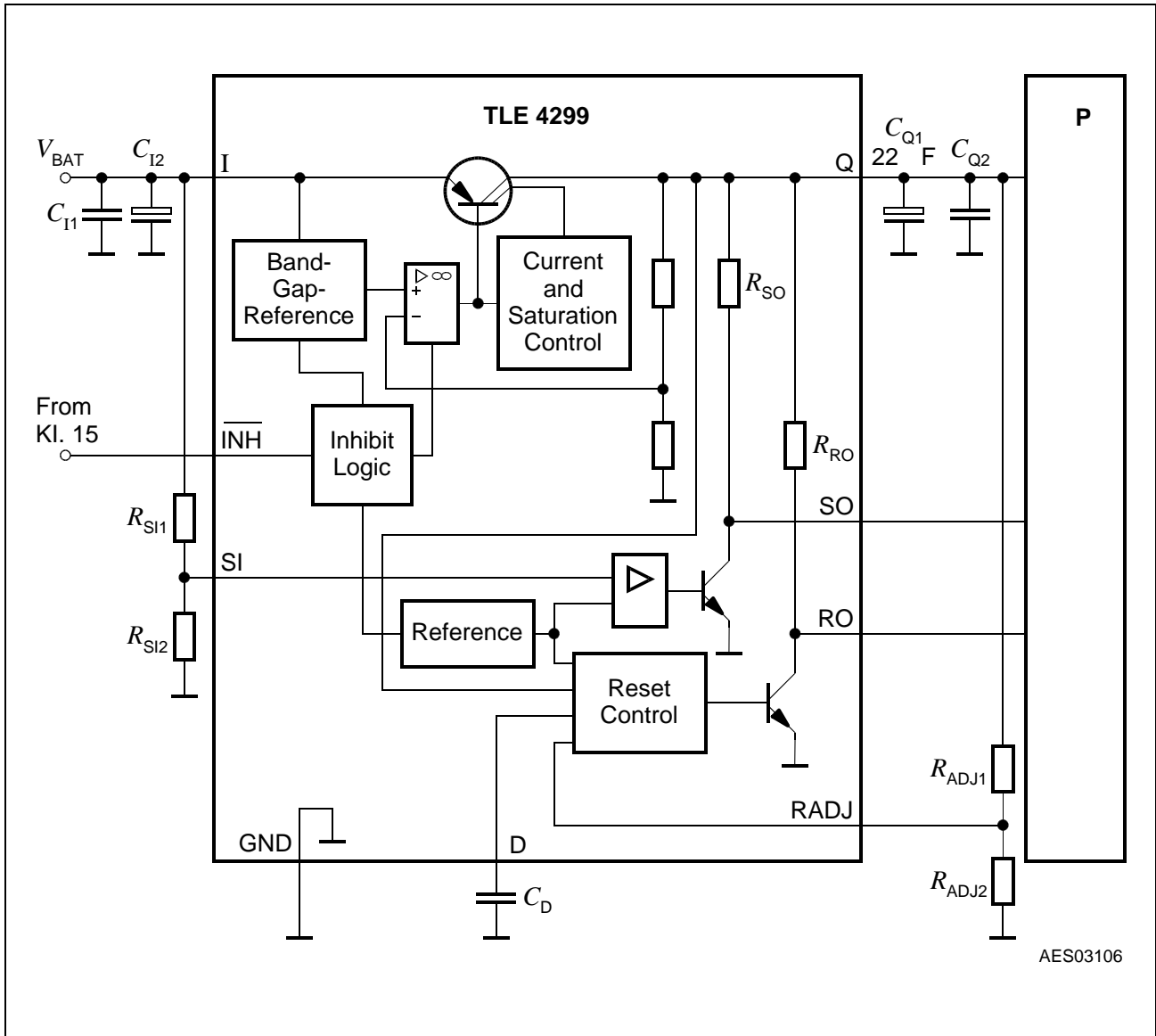

Figure 7 Application Diagram with Inhibit Function

The TLE 4299 supplies a regulated 5 V output voltage with an accuracy of 2% from an input voltage between 5.5 V and 45 V in the temperature range of $T_j = -40$ to 150 °C.

The device is capable to supply 150 mA. For protection at high input voltage above 25 V, the output current is reduced (SOA protection).

An input capacitor is necessary for compensating line influences and to limit steep input edges. A resistor of approx. 1 Ω in series with C_I , can damp the LC of the input inductivity and the input capacitor.

The voltage regulator requires for stability an output capacitor C_Q of at least 22 μF with an ESR below 5 Ω .

Reset

The power on reset feature is necessary for a defined start of the microprocessor when switching on the application. For the reset delay time after the output voltage of the regulator is above the reset threshold, the reset signal is set High again. The reset delay time is defined by the reset delay capacitor C_D at pin D.

The under-voltage reset circuitry supervises the output voltage. In case V_Q decreases below the reset threshold the reset output is set LOW after the reset reaction time. The reset LOW signal is generated down to an output voltage V_Q to 1 V. Both the reset reaction time and the reset delay time is defined by the capacitor value.

The power on reset delay time is defined by the charging time of an external delay capacitor C_D .

$$C_D = (t_d \times I_D) / \Delta V \quad [1]$$

With C_D reset delay capacitor
 t_d reset delay time
 $\Delta V = V_{UD}$, typical 1.8 V for power up reset
 $\Delta V = V_{UD} - V_{LD}$ typical 1.35 V for undervoltage reset
 I_D charge current typical 6.5 μ A

For a delay capacitor $C_D = 100$ nF the typical power on reset delay time is 28 ms.

The reset reaction time t_{RR} is the time it takes the voltage regulator to set reset output LOW after the output voltage has dropped below the reset threshold. It is typically 1 μ s for delay capacitor of 100 nF. For other values for C_D the reaction time can be estimated using the following equation:

$$t_{RR} = 10 \text{ ns} / \text{nF} \times C_D \quad [2]$$

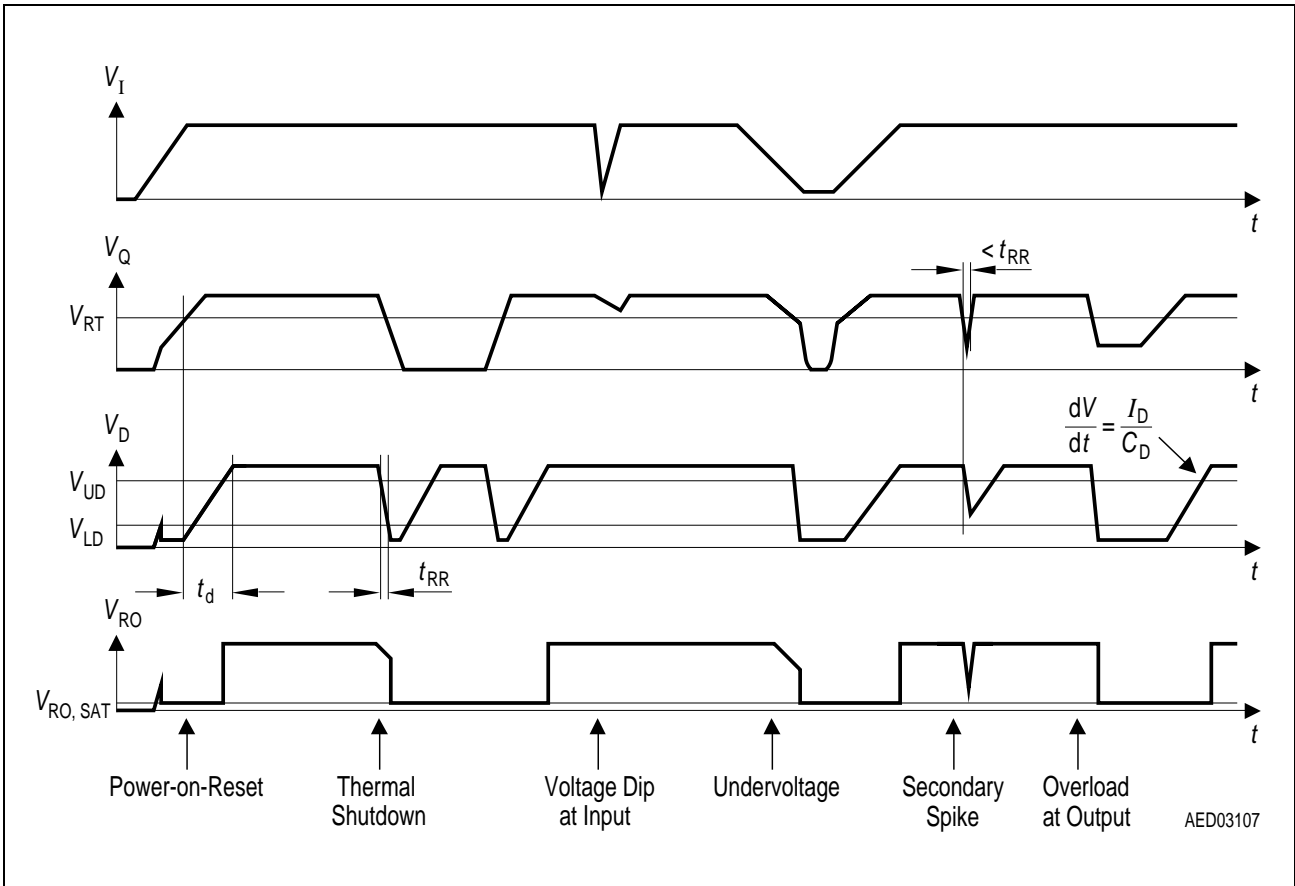

AED03107

Figure 8 Reset Timing Diagram

The reset output is an open collector output with a pull-up resistor of typical 20 kΩ to Q. An external pull-up can be added with a resistor value of at least 5.6 kΩ.

In addition the reset switching threshold can be adjusted by an external voltage divider. The feature is useful for microprocessors which guarantee safe operation down to voltages below the internally set reset threshold of 4.65 V typical.

If the internal used reset threshold of typical 4.65 V is used, the pin RADJ has to be connected to GND.

If a lower reset threshold is required by the system, a voltage divider defines the reset threshold V_{Rth} between 3.5 V and 4.60 V:

$$V_{Rth} = V_{RADJ TH} \times (R_{ADJ1} + R_{ADJ2}) / R_{ADJ2} \quad [3]$$

$V_{RADJ TH}$ is typical 1.36 V.

Early Warning

The early warning function compares a voltage defined by the user to an internal reference voltage. Therefore the supervised voltage has to be scaled down by an external voltage divider in order to compare it to the internal sense threshold of typical 1.35 V. The sense output pin is set low, when the voltage at SI falls below this threshold.

A typical example where the circuit can be used is to supervise the input voltage V_I to give the microcontroller a prewarning of low battery condition.

Calculation to the voltage divider can be easily done since the sense input current can be neglected.

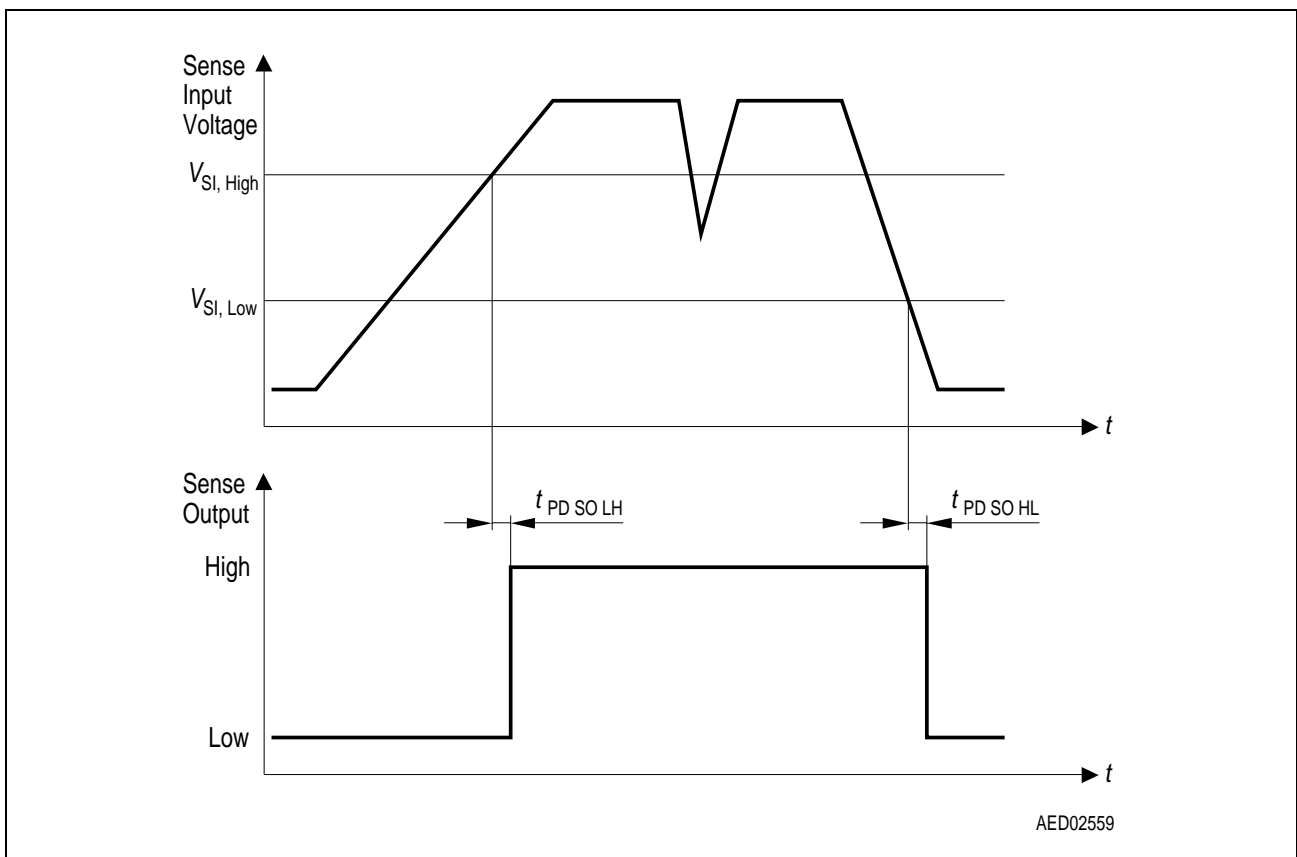

Figure 9 Sense Timing Diagram

$$V_{thHL} = (R_{SI1} + R_{SI2})/R_{SI2} \times V_{SI\ low} \quad [4]$$

$$V_{thLH} = (R_{SI1} + R_{SI2})/R_{SI2} \times V_{SI\ high} \quad [5]$$

The sense in comparator uses a hysteresis of typical 100 mV. This hysteresis of the supervised threshold is multiplied by the resistor dividers amplification $(R_{SI1} + R_{SI2})/R_{SI1}$.

The sense in comparator can also be used for receiving data with a threshold of typical 1.35 V and a hysteresis of 100 mV. Of course also the data signal can be scaled down with a resistive divider as shown above. With a typical delay time of 2.4 μ s for positive transitions and 1.7 μ s for negative transitions receiving data of up to 100 kBaud are possible.

The sense output is an open collector output with a pull-up resistor of typical 20 kΩ to Q. An external pull-up can be added with a resistor value of at least 5.6 kΩ.

Typical Performance Characteristics

Output Voltage V_Q versus Temperature T_j

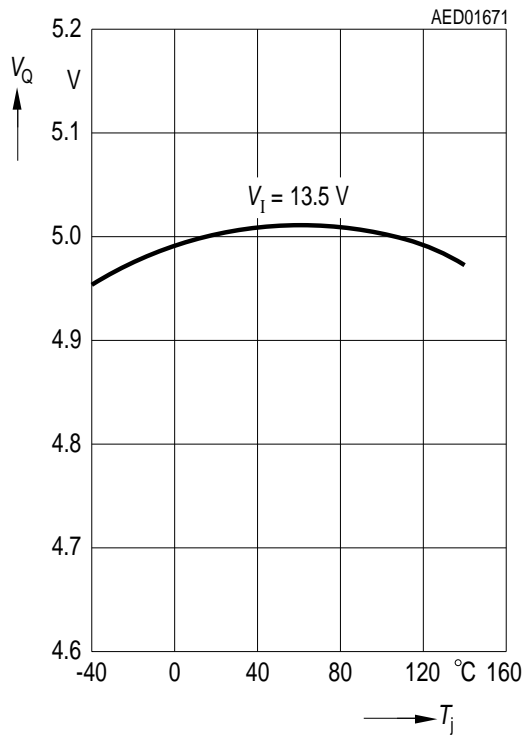

Output Voltage V_Q versus Input Voltage V_I

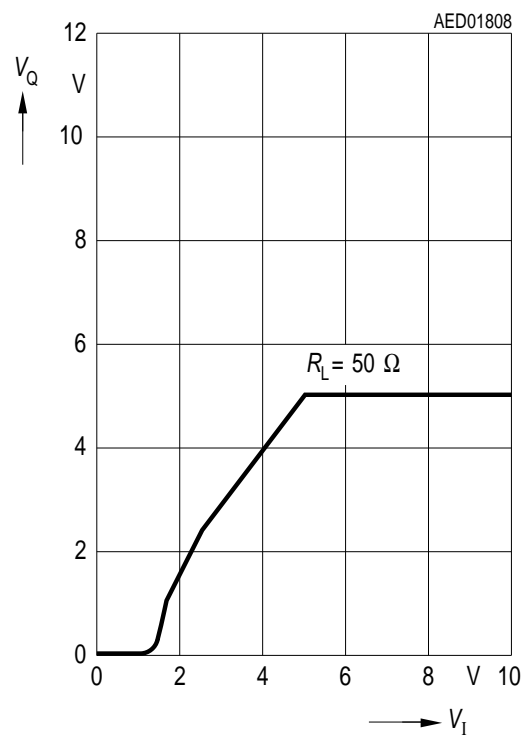

Charge Current I_{ch} versus Temperature T_j

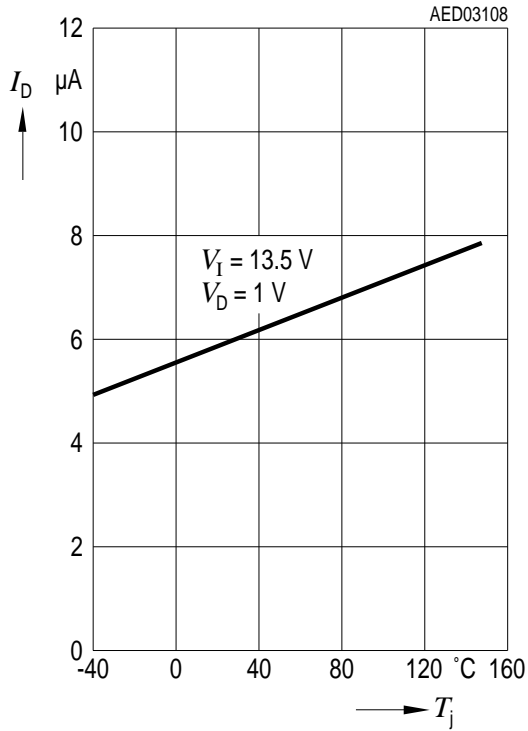

Drop Voltage V_{dr} versus Output Current I_Q

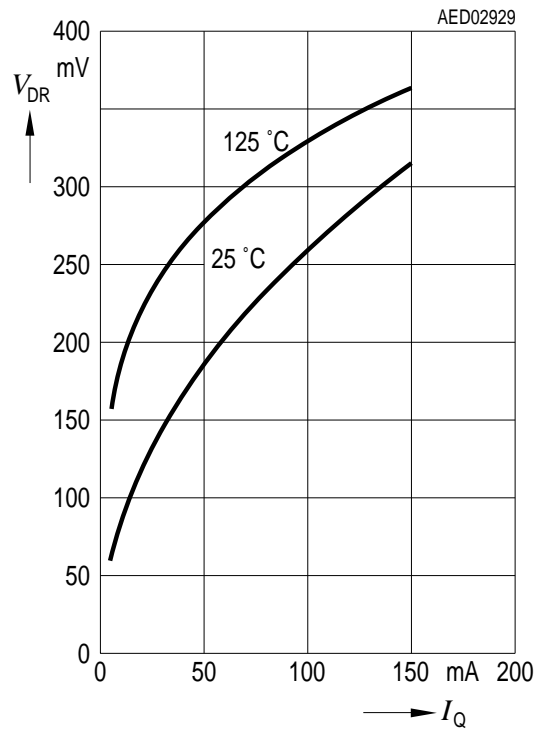

Switching Voltage V_{dt} and V_{st} versus Temperature T_j

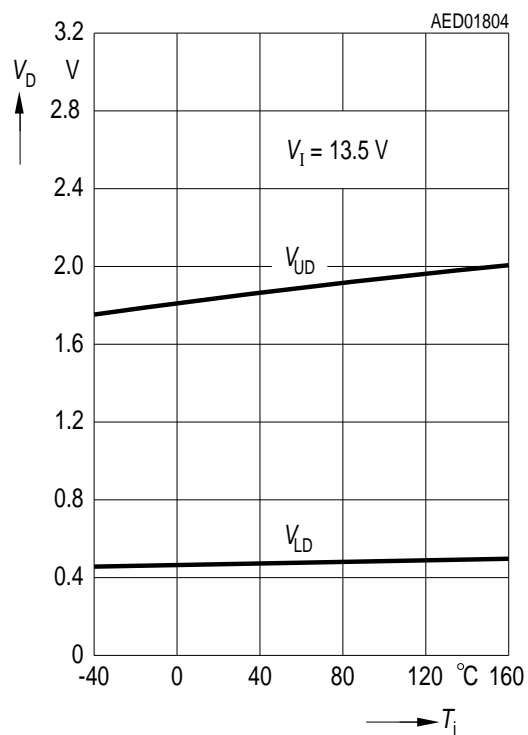

Reset Adjust Switching Threshold V_{RADJTH} versus Temperature T_j

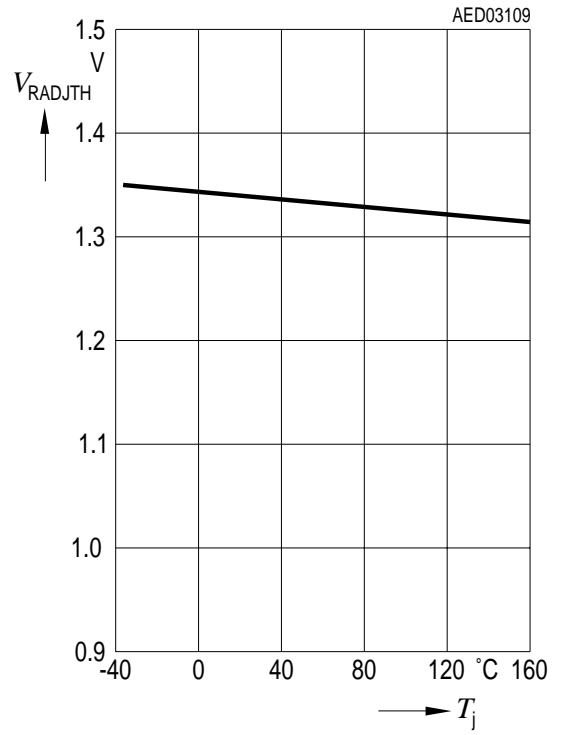

Sense Threshold V_{Si} versus Temperature T_j

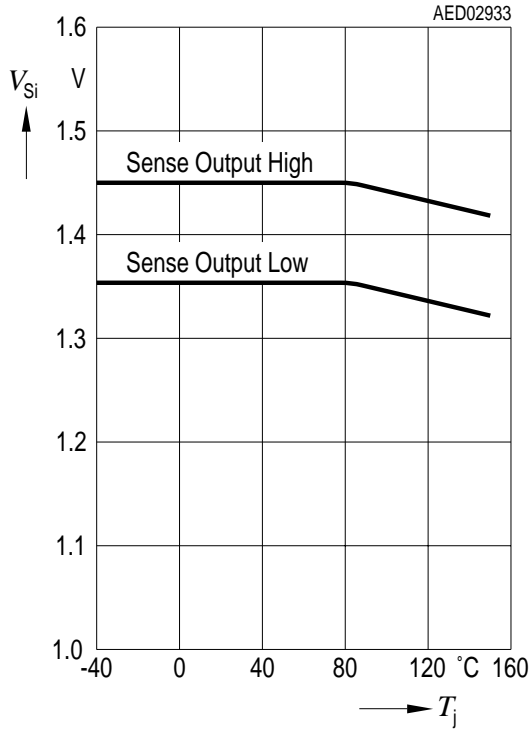

Output Current Limit I_Q versus Input Voltage V_I

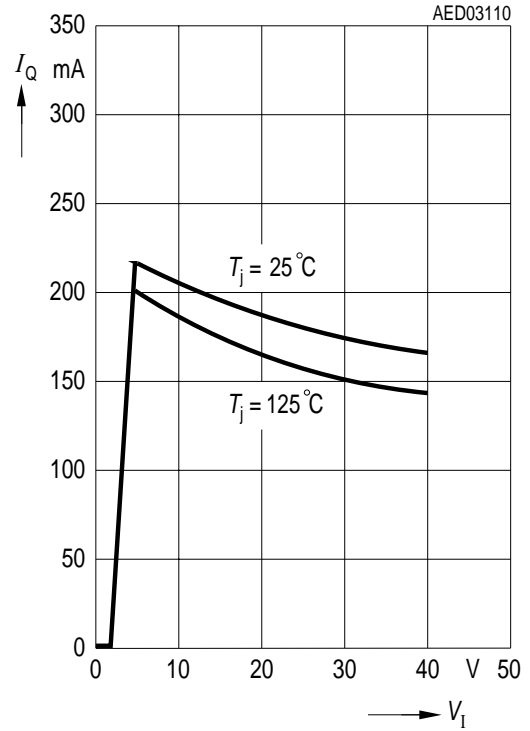

Current Consumption I_q versus Output Current I_Q

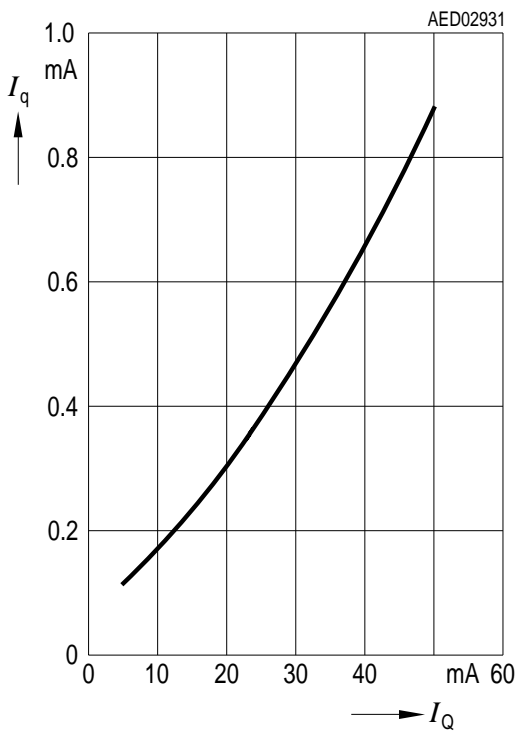

Current Consumption I_q versus Output Current I_Q

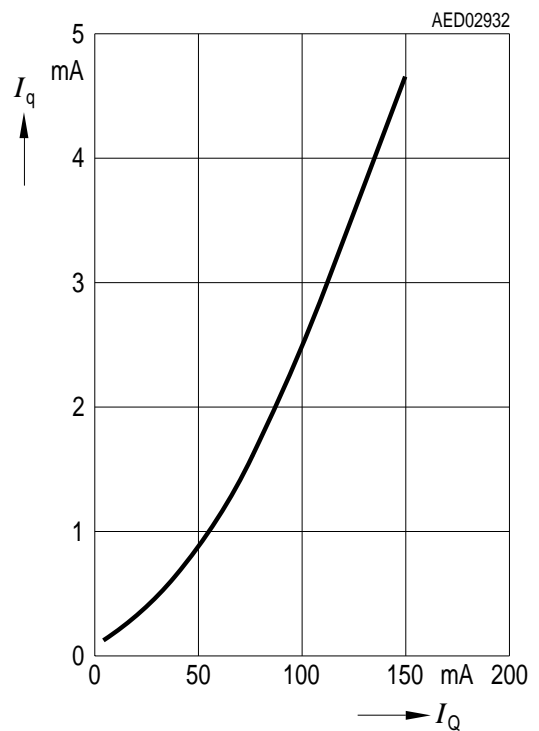

Package Outlines

P-DSO-8-3 (SMD)
(Plastic Dual Small Outline)

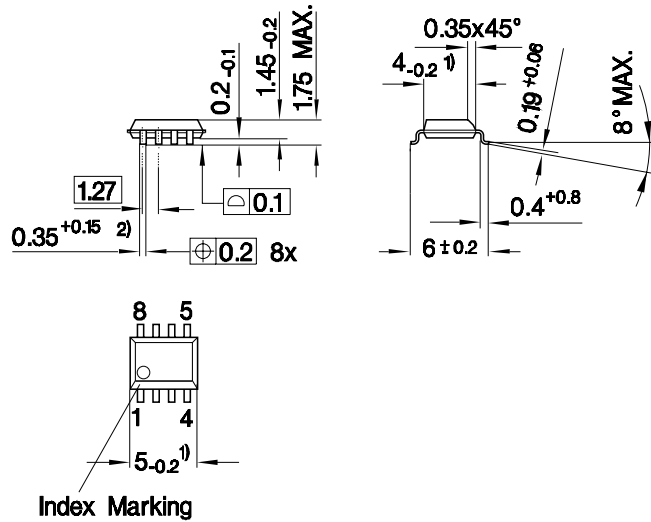

- 1) Does not include plastic or metal protrusion of 0.15 max. per side
- 2) Lead width can be 0.61 max. in dambar area

GPS05121

Sorts of Packing

Package outlines for tubes, trays etc. are contained in our Data Book "Package Information"

SMD = Surface Mounted Device

Dimensions in mm

P-DSO-14-8 (SMD)
(Plastic Dual Small Outline)

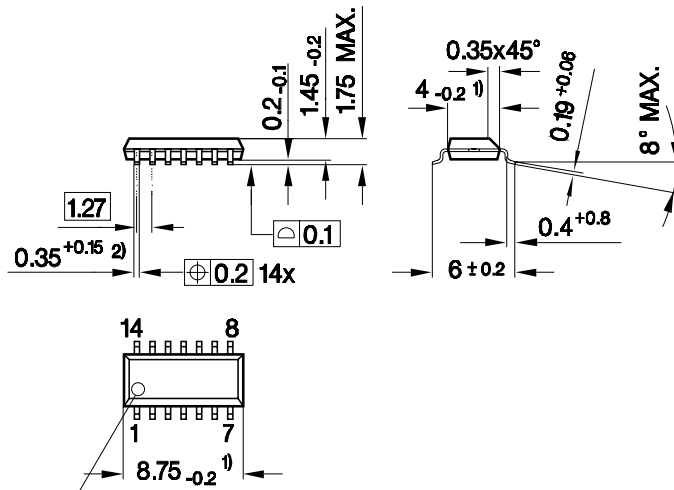

Index Marking

- 1) Does not include plastic or metal protrusion of 0.15 max. per side
- 2) Lead width can be 0.61 max. in dambar area

GPS05093

Sorts of Packing

Package outlines for tubes, trays etc. are contained in our Data Book "Package Information"

SMD = Surface Mounted Device

Dimensions in mm

Edition 2002-01-17

**Published by Infineon Technologies AG,
St.-Martin-Strasse 53,
D-81541 München, Germany**

**© Infineon Technologies AG 2002.
All Rights Reserved.**

Attention please!

The information herein is given to describe certain components and shall not be considered as warranted characteristics.

Terms of delivery and rights to technical change reserved.

We hereby disclaim any and all warranties, including but not limited to warranties of non-infringement, regarding circuits, descriptions and charts stated herein.

Infineon Technologies is an approved CECC manufacturer.

Information

For further information on technology, delivery terms and conditions and prices please contact your nearest Infineon Technologies Office in Germany or our Infineon Technologies Representatives worldwide (see address list).

Warnings

Due to technical requirements components may contain dangerous substances. For information on the types in question please contact your nearest Infineon Technologies Office.

Infineon Technologies Components may only be used in life-support devices or systems with the express written approval of Infineon Technologies, if a failure of such components can reasonably be expected to cause the failure of that life-support device or system, or to affect the safety or effectiveness of that device or system. Life support devices or systems are intended to be implanted in the human body, or to support and/or maintain and sustain and/or protect human life. If they fail, it is reasonable to assume that the health of the user or other persons may be endangered.