

FSAM30SH60A

SPM™ (Smart Power Module)

General Description

FSAM30SH60A is an advanced smart power module (SPM) that Fairchild has newly developed and designed to provide very compact and high performance ac motor drives mainly targeting high speed low-power inverter-driven application like washing machines. It combines optimized circuit protection and drive matched to low-loss IGBTs. Highly effective short-circuit current detection/protection is realized through the use of advanced current sensing IGBT chips that allow continuous monitoring of the IGBTs current. System reliability is further enhanced by the built-in over-temperature monitoring and integrated under-voltage lock-out protection. The high speed built-in HVIC provides opto-coupler-less IGBT gate driving capability that further reduce the overall size of the inverter system design. In addition the incorporated HVIC facilitates the use of single-supply drive topology enabling the FSAM30SH60A to be driven by only one drive supply voltage without negative bias. Inverter current sensing application can be achieved due to the divided negative dc terminals.

Features

- UL Certified No. E209204
- 600V-30A 3-phase IGBT inverter bridge including control ICs for gate driving and protection
- Divided negative dc-link terminals for inverter current sensing applications
- Single-grounded power supply due to built-in HVIC
- Typical switching frequency of 15kHz
- Built-in thermistor for over-temperature monitoring
- Inverter power rating of 2.4kW / 100~253 Vac
- Isolation rating of 2500Vrms/min.
- Very low leakage current due to using ceramic substrate
- Adjustable current protection level by varying series resistor value with sense-IGBTs

Applications

- AC 100V ~ 253V 3-phase inverter drive for small power (2.4kW) ac motor drives
- Home appliances applications requiring high switching frequency operation like washing machines drive system
- Application ratings:
 - Power : 2.4kW / 100~253 Vac
 - Switching frequency : Typical 15kHz (PWM Control)
 - 100% load current : 11A (Irms)
 - 150% load current : 16.5A (Irms) for 1 minute

External View

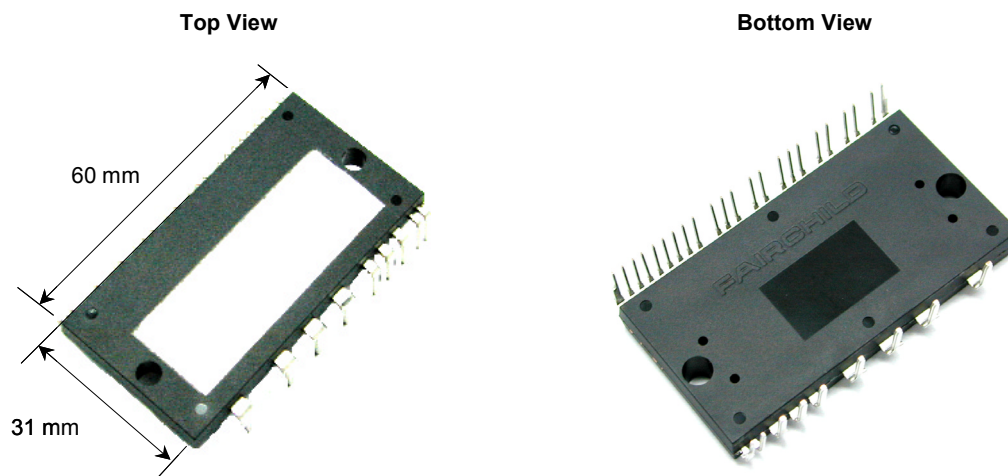

Fig. 1.

Integrated Power Functions

- 600V-30A IGBT inverter for 3-phase DC/AC power conversion (Please refer to Fig. 3)

Integrated Drive, Protection and System Control Functions

- For inverter high-side IGBTs: Gate drive circuit, High voltage isolated high-speed level shifting
Control circuit under-voltage (UV) protection
Note) Available bootstrap circuit example is given in Figs. 14 and 15.
- For inverter low-side IGBTs: Gate drive circuit, Short-Circuit (SC) protection
Control supply circuit under-voltage (UV) protection
- Temperature Monitoring: System over-temperature monitoring using built-in thermistor
Note) Available temperature monitoring circuit is given in Fig. 15.
- Fault signaling: Corresponding to a SC fault (Low-side IGBTs) or a UV fault (Low-side control supply circuit)
- Input interface: 5V CMOS/LSTTL compatible, Schmitt trigger input

Pin Configuration

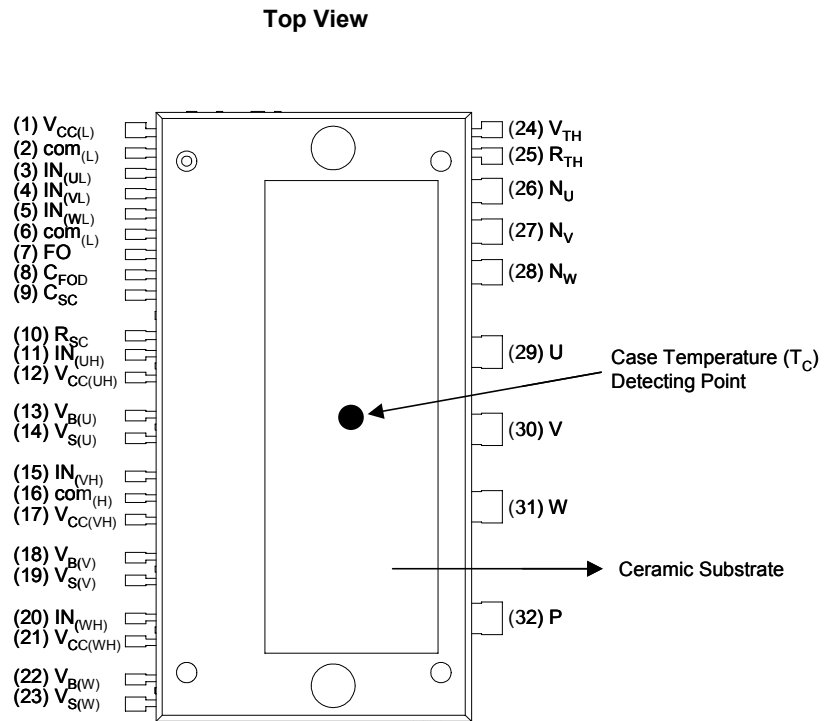

Fig. 2.

Pin Descriptions

Pin Number	Pin Name	Pin Description
1	$V_{CC(L)}$	Low-side Common Bias Voltage for IC and IGBTs Driving
2	$COM_{(L)}$	Low-side Common Supply Ground
3	$IN_{(UL)}$	Signal Input for Low-side U Phase
4	$IN_{(VL)}$	Signal Input for Low-side V Phase
5	$IN_{(WL)}$	Signal Input for Low-side W Phase
6	$COM_{(L)}$	Low-side Common Supply Ground
7	V_{FO}	Fault Output
8	C_{FOD}	Capacitor for Fault Output Duration Time Selection
9	C_{SC}	Capacitor (Low-pass Filter) for Short-Circuit Current Detection Input
10	R_{SC}	Resistor for Short-Circuit Current Detection
11	$IN_{(UH)}$	Signal Input for High-side U Phase
12	$V_{CC(UH)}$	High-side Bias Voltage for U Phase IC
13	$V_{B(U)}$	High-side Bias Voltage for U Phase IGBT Driving
14	$V_{S(U)}$	High-side Bias Voltage Ground for U Phase IGBT Driving
15	$IN_{(VH)}$	Signal Input for High-side V Phase
16	$COM_{(H)}$	High-side Common Supply Ground
17	$V_{CC(VH)}$	High-side Bias Voltage for V Phase IC
18	$V_{B(V)}$	High-side Bias Voltage for V Phase IGBT Driving
19	$V_{S(V)}$	High-side Bias Voltage Ground for V Phase IGBT Driving
20	$IN_{(WH)}$	Signal Input for High-side W Phase
21	$V_{CC(WH)}$	High-side Bias Voltage for W Phase IC
22	$V_{B(W)}$	High-side Bias Voltage for W Phase IGBT Driving
23	$V_{S(W)}$	High-side Bias Voltage Ground for W Phase IGBT Driving
24	V_{TH}	Thermistor Bias Voltage
25	R_{TH}	Series Resistor for the Use of Thermistor (Temperature Detection)
26	N_U	Negative DC-Link Input for U Phase
27	N_V	Negative DC-Link Input for V Phase
28	N_W	Negative DC-Link Input for W Phase
29	U	Output for U Phase
30	V	Output for V Phase
31	W	Output for W Phase
32	P	Positive DC-Link Input

Internal Equivalent Circuit and Input/Output Pins

Bottom View



Note:

- 1) Inverter low-side is composed of three sense-IGBTs including freewheeling diodes for each IGBT and one control IC which has gate driving, current sensing and protection functions.
- 2) Inverter power side is composed of four inverter dc-link input pins and three inverter output pins.
- 3) Inverter high-side is composed of three normal-IGBTs including freewheeling diodes and three drive ICs for each IGBT.

Fig. 3.

Absolute Maximum Ratings

Inverter Part ($T_C = 25^\circ\text{C}$, Unless Otherwise Specified)

Item	Symbol	Condition	Rating	Unit
Supply Voltage	V_{PN}	Applied between P- N	450	V
Supply Voltage (Surge)	$V_{PN(\text{Surge})}$	Applied between P- N	500	V
Collector-Emitter Voltage	V_{CES}		600	V
Each IGBT Collector Current	$\pm I_C$	$T_C = 25^\circ\text{C}$	30	A
Each IGBT Collector Current	$\pm I_C$	$T_C = 100^\circ\text{C}$	15	A
Each IGBT Collector Current (Peak)	$\pm I_{CP}$	$T_C = 25^\circ\text{C}$	60	A
Collector Dissipation	P_C	$T_C = 25^\circ\text{C}$ per One Chip	62	W
Operating Junction Temperature	T_J	(Note 1)	-55 ~ 150	$^\circ\text{C}$

Note:

1. It would be recommended that the average junction temperature should be limited to $T_J \leq 125^\circ\text{C}$ ($@T_C \leq 100^\circ\text{C}$) in order to guarantee safe operation.

Control Part ($T_C = 25^\circ\text{C}$, Unless Otherwise Specified)

Item	Symbol	Condition	Rating	Unit
Control Supply Voltage	V_{CC}	Applied between $V_{CC(H)}$ - $COM_{(H)}$, $V_{CC(L)}$ - $COM_{(L)}$	18	V
High-side Control Bias Voltage	V_{BS}	Applied between $V_{B(U)}$ - $V_{S(U)}$, $V_{B(V)}$ - $V_{S(V)}$, $V_{B(W)}$ - $V_{S(W)}$	20	V
Input Signal Voltage	V_{IN}	Applied between $IN_{(UH)}$, $IN_{(VH)}$, $IN_{(WH)}$ - $COM_{(H)}$ $IN_{(UL)}$, $IN_{(VL)}$, $IN_{(WL)}$ - $COM_{(L)}$	-0.3 ~ 6.0	V
Fault Output Supply Voltage	V_{FO}	Applied between V_{FO} - $COM_{(L)}$	-0.3~ $V_{CC}+0.5$	V
Fault Output Current	I_{FO}	Sink Current at V_{FO} Pin	5	mA
Current Sensing Input Voltage	V_{SC}	Applied between C_{SC} - $COM_{(L)}$	-0.3~ $V_{CC}+0.5$	V

Total System

Item	Symbol	Condition	Rating	Unit
Self Protection Supply Voltage Limit (Short-Circuit Protection Capability)	$V_{PN(\text{PROT})}$	$V_{CC} = V_{BS} = 13.5 \sim 16.5\text{V}$ $T_J = 125^\circ\text{C}$, Non-repetitive, less than $6\mu\text{s}$	400	V
Module Case Operation Temperature	T_C	Note Fig.2	-20 ~ 100	$^\circ\text{C}$
Storage Temperature	T_{STG}		-50 ~ 150	$^\circ\text{C}$
Isolation Voltage	V_{ISO}	60Hz, Sinusoidal, AC 1 minute, Connection Pins to Heat-sink Plate	2500	V_{rms}

Absolute Maximum Ratings

Thermal Resistance

Item	Symbol	Condition	Min.	Typ.	Max.	Unit
Junction to Case Thermal Resistance	$R_{th(j-c)Q}$	Each IGBT under Inverter Operating Condition	-	-	2.0	°C/W
	$R_{th(j-c)F}$	Each FWDi under Inverter Operating Condition	-	-	3.2	°C/W
Contact Thermal Resistance	$R_{th(c-f)}$	Ceramic Substrate (per 1 Module) Thermal Grease Applied (Note 3)	-	-	0.06	°C/W

Note:

- For the measurement point of case temperature(T_C), please refer to Fig. 2.
- The thickness of thermal grease should not be more than 100um.

Electrical Characteristics

Inverter Part ($T_J = 25^\circ\text{C}$, Unless Otherwise Specified)

Item	Symbol	Condition	Min.	Typ.	Max.	Unit	
Collector - Emitter Saturation Voltage	$V_{CE(SAT)}$	$V_{CC} = V_{BS} = 15V$ $V_{IN} = 0V$	$I_C = 30A, T_J = 25^\circ\text{C}$	-	-	2.5	V
			$I_C = 30A, T_J = 125^\circ\text{C}$	-	-	2.6	V
FWDi Forward Voltage	V_{FM}	$V_{IN} = 5V$	$I_C = 30A, T_J = 25^\circ\text{C}$	-	-	2.6	V
			$I_C = 30A, T_J = 125^\circ\text{C}$	-	-	2.4	V
Switching Times	t_{ON}	$V_{PN} = 300V, V_{CC} = V_{BS} = 15V$ $I_C = 30A, T_J = 25^\circ\text{C}$ $V_{IN} = 5V \leftrightarrow 0V$, Inductive Load (High, Low-side) (Note 4)	-	0.39	-	us	
	$t_{C(ON)}$		-	0.2	-	us	
	t_{OFF}		-	0.85	-	us	
	$t_{C(OFF)}$		-	0.24	-	us	
	t_{rr}		-	0.13	-	us	
Collector - Emitter Leakage Current	I_{CES}	$V_{CE} = V_{CES}, T_J = 25^\circ\text{C}$	-	-	250	uA	

Note:

- t_{ON} and t_{OFF} include the propagation delay time of the internal drive IC. $t_{C(ON)}$ and $t_{C(OFF)}$ are the switching time of IGBT itself under the given gate driving condition internally. For the detailed information, please see Fig. 4.

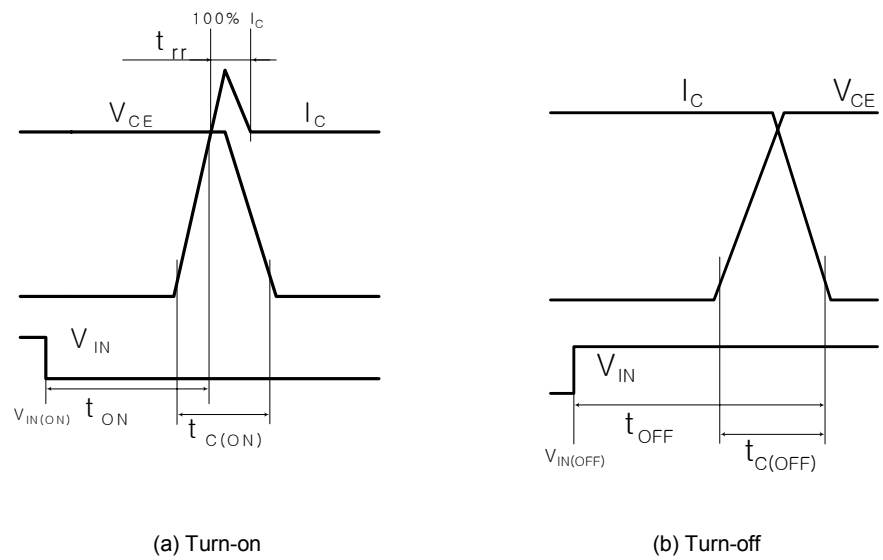

Fig. 4. Switching Time Definition

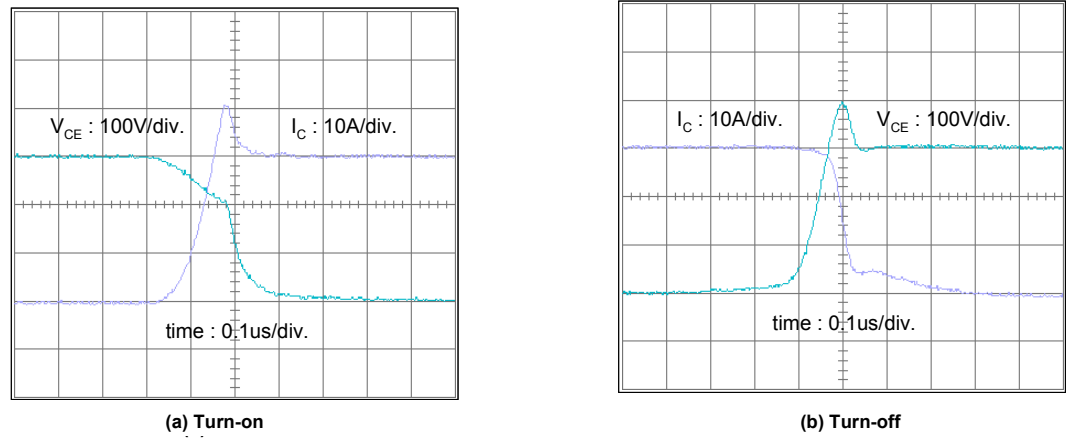

Fig. 5. Experimental Results of Switching Waveforms
 Test Condition: $V_{dc}=300V$, $V_{cc}=15V$, $L=500\mu H$ (Inductive Load), $T_c=25^\circ C$

Electrical Characteristics

Control Part (T_J = 25°C, Unless Otherwise Specified)

Item	Symbol	Condition	Min.	Typ.	Max.	Unit	
Control Supply Voltage	V _{CC}	Applied between V _{CC(UH)} , V _{CC(VH)} , V _{CC(WH)} , V _{CC(L)} - COM	13.5	15	16.5	V	
High-side Bias Voltage	V _{BS}	Applied between V _{B(U)} - V _{S(U)} , V _{B(V)} - V _{S(V)} , V _{B(W)} - V _{S(W)}	13.5	15	16.5	V	
Quiescent V _{CC} Supply Current	I _{QCCL}	V _{CC} = 15V I _{N(UH, VL, WL)} = 5V	V _{CC(L)} - COM _(L)	-	-	26 mA	
	I _{QCCH}	V _{CC} = 15V I _{N(UH, VH, WH)} = 5V	V _{CC(U)} , V _{CC(V)} , V _{CC(W)} - COM _(H)	-	-	130 uA	
Quiescent V _{BS} Supply Current	I _{QBS}	V _{BS} = 15V I _{N(UH, VH, WH)} = 5V	V _{B(U)} - V _{S(U)} , V _{B(V)} - V _{S(V)} , V _{B(W)} - V _{S(W)}	-	-	420 uA	
Fault Output Voltage	V _{FOH}	V _{SC} = 0V, V _{FO} Circuit: 4.7kΩ to 5V Pull-up	4.5	-	-	V	
	V _{FOL}	V _{SC} = 1V, V _{FO} Circuit: 4.7kΩ to 5V Pull-up	-	-	1.1	V	
PWM Input Frequency	f _{PWM}	T _C ≤ 100°C, T _J ≤ 125°C	-	15	-	kHz	
Allowable Input Signal Blanking Time considering Leg Arm-short	t _{dead}	-20°C ≤ T _C ≤ 100°C	3	-	-	us	
Short-Circuit Trip Level	V _{SC(ref)}	-20°C ≤ T _J ≤ 125°C, V _{CC} = 15V (Note 5)	0.45	0.51	0.56	V	
Sensing Voltage of IGBT Current	V _{SEN}	T _C = 25°C, @ R _{SC} = 50 Ω, R _{SU} = R _{SV} = R _{SW} = 0 Ω and I _C = 45A (Note Fig. 7)	0.45	0.51	0.56	V	
Supply Circuit Under-Voltage Protection	UV _{CCD}	T _J ≤ 125°C	Detection Level	11.5	12	12.5	V
	UV _{CCR}		Reset Level	12	12.5	13	V
	UV _{BSD}		Detection Level	7.3	9.0	10.8	V
	UV _{BSR}		Reset Level	8.6	10.3	12	V
Fault Output Pulse Width	t _{FOD}	C _{FOD} = 33nF (Note 6)	1.4	1.8	2.0	ms	
ON Threshold Voltage	V _{IN(ON)}	High-Side	Applied between I _{N(UH)} , I _{N(VH)} , I _{N(WH)} - COM _(H)	-	-	0.8	V
OFF Threshold Voltage	V _{IN(OFF)}			3.0	-	-	V
ON Threshold Voltage	V _{IN(ON)}	Low-Side	Applied between I _{N(UL)} , I _{N(VL)} , I _{N(WL)} - COM _(L)	-	-	0.8	V
OFF Threshold Voltage	V _{IN(OFF)}			3.0	-	-	V
Resistance of Thermistor	R _{TH}	@ T _C = 25°C (Note Fig. 6)	-	50	-	kΩ	
		@ T _C = 80°C (Note Fig. 6)	-	6.3	-	kΩ	

Note:

- Short-circuit current protection is functioning only at the low-sides. It would be recommended that the value of the external sensing resistor (R_{SC}) should be selected around 50 Ω in order to make the SC trip-level of about 45A at the shunt resistors (R_{SU}, R_{SV}, R_{SW}) of 0Ω. For the detailed information about the relationship between the external sensing resistor (R_{SC}) and the shunt resistors (R_{SU}, R_{SV}, R_{SW}), please see Fig. 7.
- The fault-out pulse width t_{FOD} depends on the capacitance value of C_{FOD} according to the following approximate equation : C_{FOD} = 18.3 x 10⁻⁶ x t_{FOD}[F]

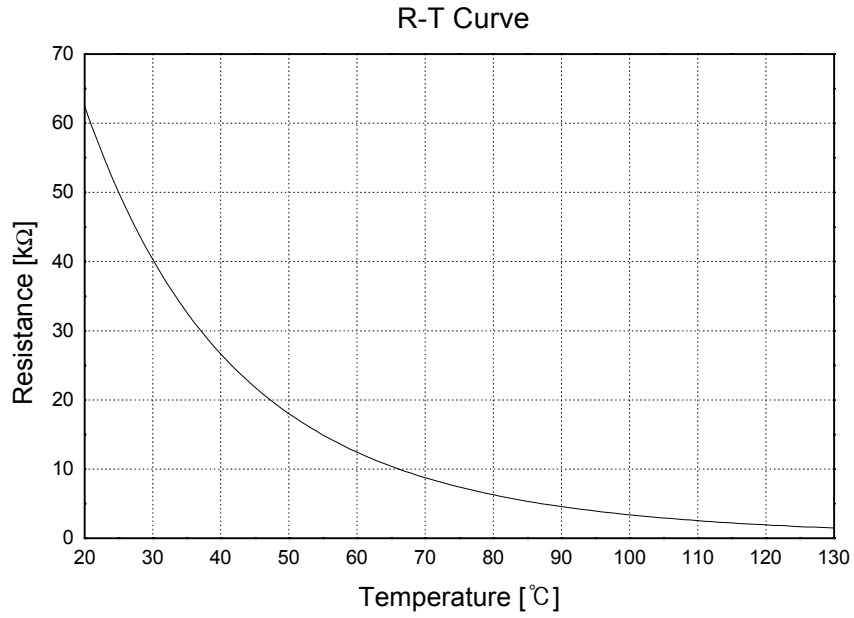

Fig. 6. R-T Curve of The Built-in Thermistor

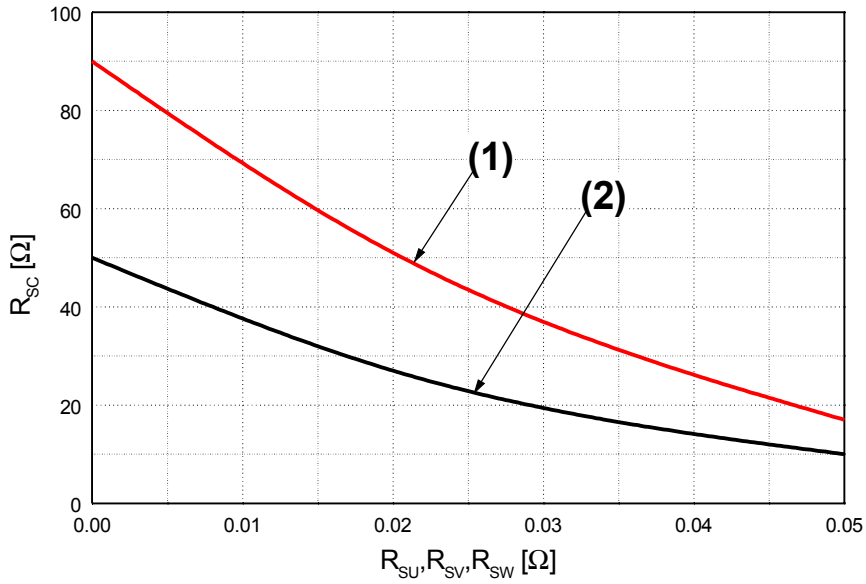

Fig. 7. R_{sc} Variation by change of Shunt Resistors (R_{SU}, R_{SV}, R_{SW}) for Short-Circuit Protection
 (1) @ around 100% Rated Current Trip (I_C = 30A)
 (2) @ around 150% Rated Current Trip (I_C = 45A)

Mechanical Characteristics and Ratings

Item	Condition	Limits			Unit	
		Min.	Typ.	Max.		
Mounting Torque	Mounting Screw: M4 (Note 7 and 8)	Recommended 10Kg•cm	8	10	12	Kg•cm
		Recommended 0.98N•m	0.78	0.98	1.17	N•m
Ceramic Flatness	Note Fig.8	0	-	+120	um	
Weight		-	35	-	g	

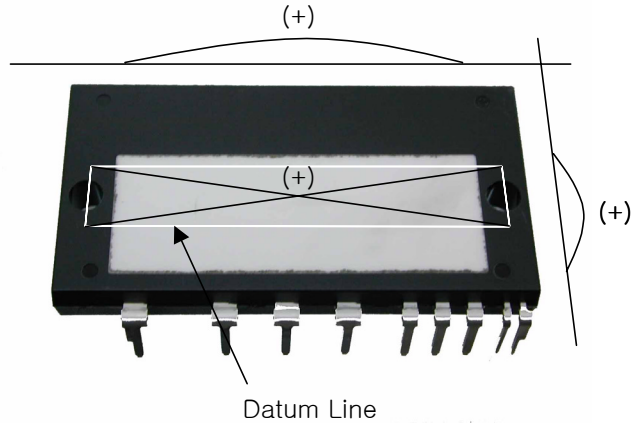

Fig. 8. Flatness Measurement Position of The Ceramic Substrate

Note:

- 7. Do not make over torque or mounting screws. Much mounting torque may cause ceramic cracks and bolts and Al heat-fin destruction.
- 8. Avoid one side tightening stress. Fig.9 shows the recommended torque order for mounting screws. Uneven mounting can cause the SPM ceramic substrate to be damaged.

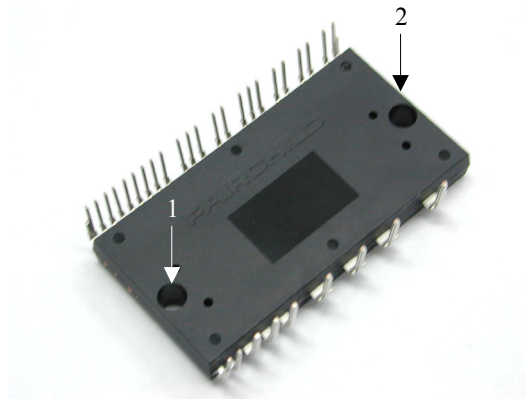
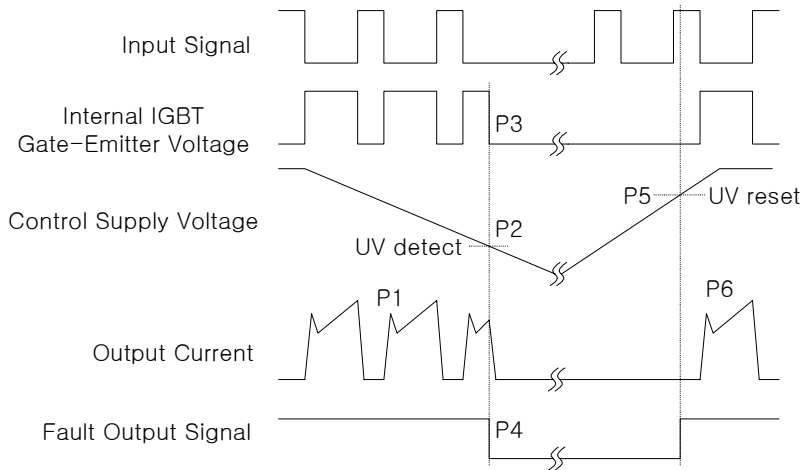

Fig. 9. Mounting Screws Torque Order

Recommended Operating Conditions

Item	Symbol	Condition	Values			Unit
			Min.	Typ.	Max.	
Supply Voltage	V_{PN}	Applied between P - N	-	300	400	V
Control Supply Voltage	V_{CC}	Applied between $V_{CC(H)}$ - COM, $V_{CC(L)}$ - COM	13.5	15	16.5	V
High-side Bias Voltage	V_{BS}	Applied between $V_{B(U)} - V_{S(U)}$, $V_{B(V)} - V_{S(V)}$, $V_{B(W)} - V_{S(W)}$	13.5	15	16.5	V
Blanking Time for Preventing Arm-short	t_{dead}	For Each Input Signal	3	-	-	us
PWM Input Signal	f_{PWM}	$T_C \leq 100^\circ\text{C}$, $T_J \leq 125^\circ\text{C}$	-	15	-	kHz
Input ON Threshold Voltage	$V_{IN(ON)}$	Applied between U_{IN} , V_{IN} , W_{IN} - COM	0 ~ 0.65			V
Input OFF Threshold Voltage	$V_{IN(OFF)}$	Applied between U_{IN} , V_{IN} , W_{IN} - COM	4 ~ 5.5			V

Time Charts of SPMs Protective Function



- P1 : Normal operation - IGBT ON and conducting current
- P2 : Under-Voltage detection
- P3 : IGBT gate interrupt
- P4 : Fault signal generation
- P5 : Under-Voltage reset
- P6 : Normal operation - IGBT ON and conducting current

Fig. 10. Under-Voltage Protection (Low-side)

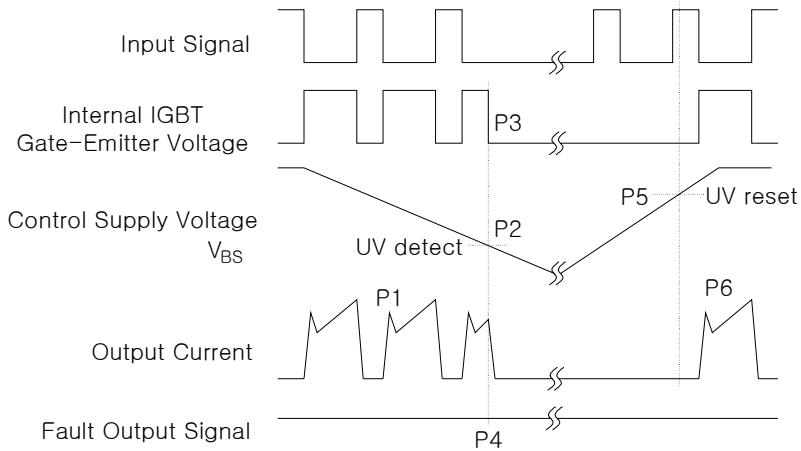

- P1 : Normal operation - IGBT ON and conducting current
- P2 : Under-Voltage detection
- P3 : IGBT gate interrupt
- P4 : No fault signal
- P5 : Under-Voltage reset
- P6 : Normal operation - IGBT ON and conducting current

Fig. 11. Under-Voltage Protection (High-side)

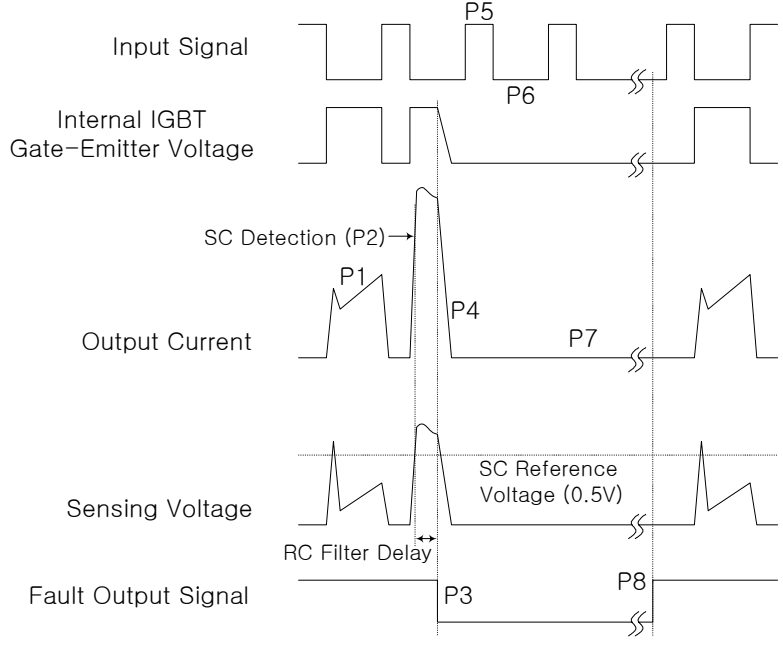

- P1 : Normal operation - IGBT ON and conducting current
- P2 : Short-Circuit current detection
- P3 : IGBT gate interrupt / Fault signal generation
- P4 : IGBT is slowly turned off
- P5 : IGBT OFF signal
- P6 : IGBT ON signal - but IGBT cannot be turned on during the fault Output activation
- P7 : IGBT OFF state
- P8 : Fault Output reset and normal operation start

Fig. 12. Short-Circuit Current Protection (Low-side Operation only)

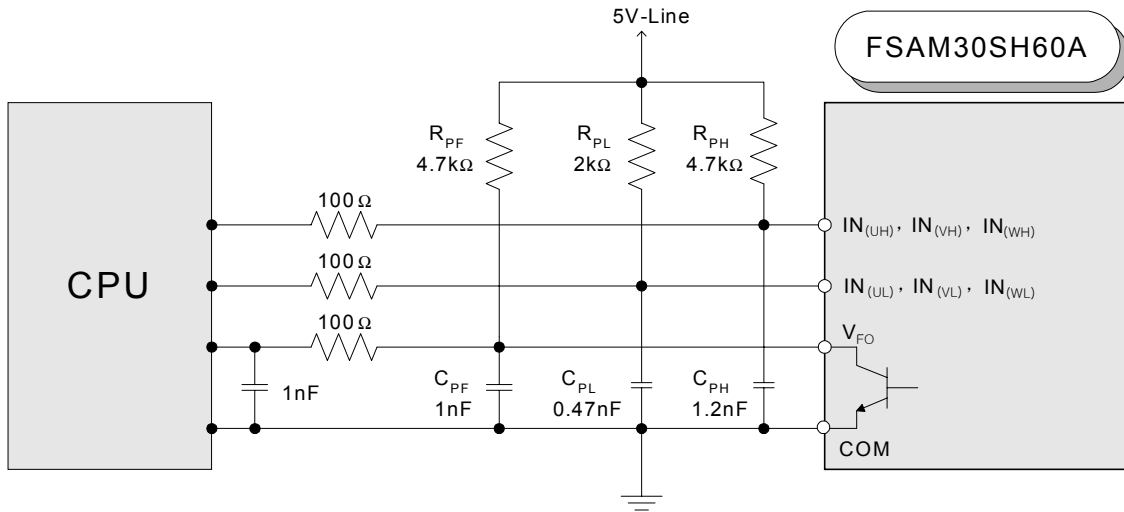

Note:

- 1) It would be recommended that by-pass capacitors for the gating input signals, $IN_{(UL)}$, $IN_{(VL)}$, $IN_{(WL)}$, $IN_{(UH)}$, $IN_{(VH)}$ and $IN_{(WH)}$ should be placed on the SPM pins and on the both sides of CPU and SPM for the fault output signal, V_{FO} , as close as possible.
- 2) The logic input is compatible with standard CMOS or LSTTL outputs.
- 3) $R_{PL}C_{PL}/R_{PH}C_{PH}/R_{PF}C_{PF}$ coupling at each SPM input is recommended in order to prevent input/output signals' oscillation and it should be as close as possible to each of SPM pins.

Fig. 13. Recommended CPU I/O Interface Circuit

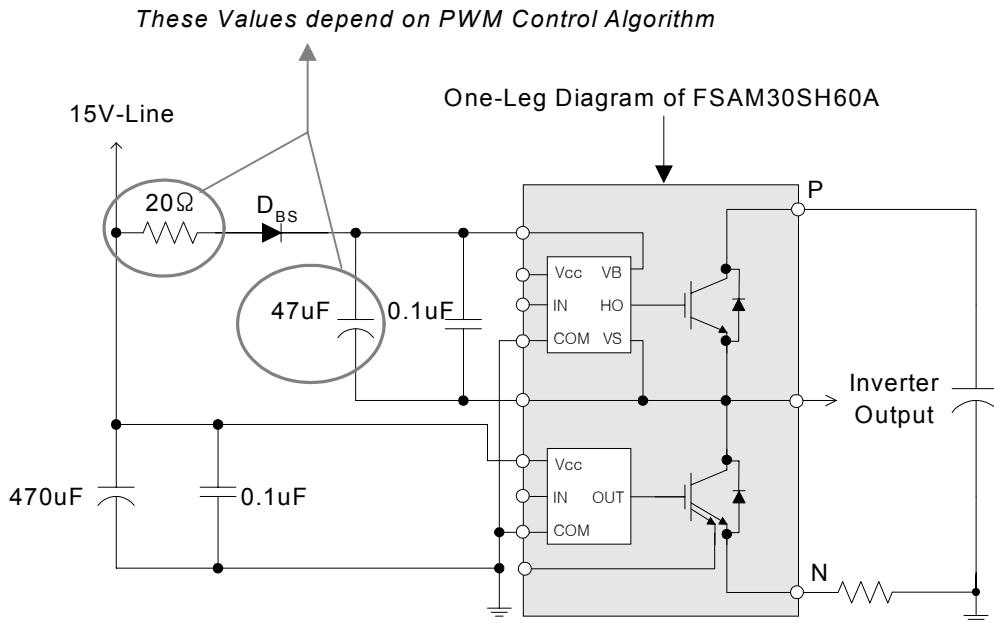

Note:

It would be recommended that the bootstrap diode, D_{BS} , has soft and fast recovery characteristics.

Fig. 14. Recommended Bootstrap Operation Circuit and Parameters

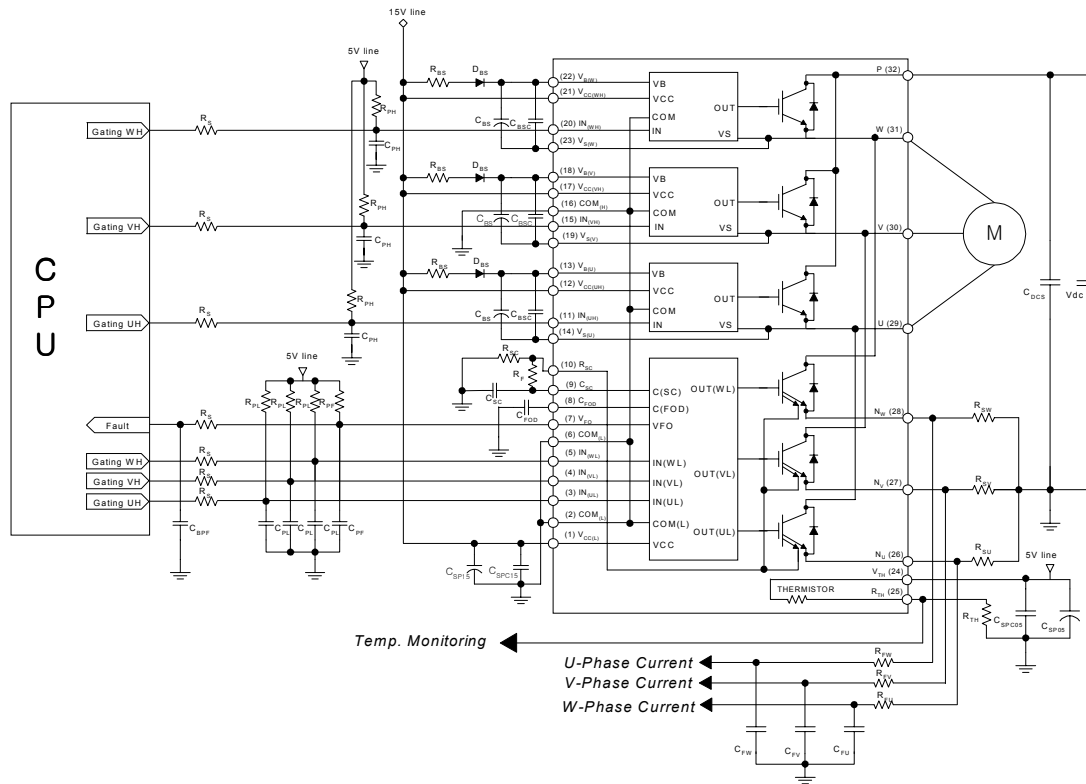

Note:

- 1) $R_{PL}C_{PL}/R_{PH}C_{PH}/R_{PF}C_{PF}$ coupling at each SPM input is recommended in order to prevent input signals' oscillation and it should be as close as possible to each SPM input pin.
- 2) By virtue of integrating an application specific type HVIC inside the SPM, direct coupling to CPU terminals without any opto-coupler or transformer isolation is possible.
- 3) V_{FO} output is open collector type. This signal line should be pulled up to the positive side of the 5V power supply with approximately 4.7k Ω resistance. Please refer to Fig. 15.
- 4) C_{SP15} of around 7 times larger than bootstrap capacitor C_{BS} is recommended.
- 5) V_{FO} output pulse width should be determined by connecting an external capacitor(C_{FOD}) between C_{FOD} (pin8) and $COM_{(L)}$ (pin2). (Example : if $C_{FOD} = 33$ nF, then $t_{FO} = 1.8$ ms (typ.)) Please refer to the note 6 for calculation method.
- 6) Each input signal line should be pulled up to the 5V power supply with approximately 4.7k Ω (at high side input) or 2k Ω (at low side input) resistance (other RC coupling circuits at each input may be needed depending on the PWM control scheme used and on the wiring impedance of the system's printed circuit board). Approximately a 0.22~2nF by-pass capacitor should be used across each power supply connection terminals.
- 7) To prevent errors of the protection function, the wiring around R_{SC} , R_F and C_{SC} should be as short as possible.
- 8) In the short-circuit protection circuit, please select the $R_F C_{SC}$ time constant in the range 3~4 μ s.
- 9) Each capacitor should be mounted as close to the pins of the SPM as possible.
- 10) To prevent surge destruction, the wiring between the smoothing capacitor and the P&N pins should be as short as possible. The use of a high frequency non-inductive capacitor of around 0.1~0.22 μ F between the P&N pins is recommended.
- 11) Relays are used at almost every systems of electrical equipments of home appliances. In these cases, there should be sufficient distance between the CPU and the relays. It is recommended that the distance be 5cm at least.

Fig. 15. Typical Application Circuit

TRADEMARKS

The following are registered and unregistered trademarks Fairchild Semiconductor owns or is authorized to use and is not intended to be an exhaustive list of all such trademarks.

ACE [™]	FACT [™]	ImpliedDisconnect [™]	PACMAN [™]	SPM [™]
ActiveArray [™]	FACT Quiet series [™]	ISOPLANAR [™]	POP [™]	Stealth [™]
Bottomless [™]	FAST [®]	LittleFET [™]	Power247 [™]	SuperSOT [™] -3
CoolFET [™]	FAST [™]	MicroFET [™]	PowerTrench [®]	SuperSOT [™] -6
CROSSVOLT [™]	FRFET [™]	MicroPak [™]	QFET [™]	SuperSOT [™] -8
DOME [™]	GlobalOptoisolator [™]	MICROWIRE [™]	QS [™]	SyncFET [™]
EcoSPARK [™]	GTO [™]	MSX [™]	QT Optoelectronics [™]	TinyLogic [™]
E ² CMOS [™]	HiSeC [™]	MSXPro [™]	Quiet Series [™]	TruTranslation [™]
EnSigna [™]	I ² C [™]	OCX [™]	RapidConfigure [™]	UHC [™]
Across the board. Around the world. [™]		OCXPro [™]	RapidConnect [™]	UltraFET [®]
The Power Franchise [™]		OPTOLOGIC [®]	SILENT SWITCHER [®]	VCX [™]
Programmable Active Droop [™]		OPTOPLANAR [™]	SMART START [™]	

DISCLAIMER

FAIRCHILD SEMICONDUCTOR RESERVES THE RIGHT TO MAKE CHANGES WITHOUT FURTHER NOTICE TO ANY PRODUCTS HEREIN TO IMPROVE RELIABILITY, FUNCTION OR DESIGN. FAIRCHILD DOES NOT ASSUME ANY LIABILITY ARISING OUT OF THE APPLICATION OR USE OF ANY PRODUCT OR CIRCUIT DESCRIBED HEREIN; NEITHER DOES IT CONVEY ANY LICENSE UNDER ITS PATENT RIGHTS, NOR THE RIGHTS OF OTHERS.

LIFE SUPPORT POLICY

FAIRCHILD'S PRODUCTS ARE NOT AUTHORIZED FOR USE AS CRITICAL COMPONENTS IN LIFE SUPPORT DEVICES OR SYSTEMS WITHOUT THE EXPRESS WRITTEN APPROVAL OF FAIRCHILD SEMICONDUCTOR CORPORATION.

As used herein:

1. Life support devices or systems are devices or systems which, (a) are intended for surgical implant into the body, or (b) support or sustain life, or (c) whose failure to perform when properly used in accordance with instructions for use provided in the labeling, can be reasonably expected to result in significant injury to the user.
2. A critical component is any component of a life support device or system whose failure to perform can be reasonably expected to cause the failure of the life support device or system, or to affect its safety or effectiveness.

PRODUCT STATUS DEFINITIONS

Definition of Terms

Datasheet Identification	Product Status	Definition
Advance Information	Formative or In Design	This datasheet contains the design specifications for product development. Specifications may change in any manner without notice.
Preliminary	First Production	This datasheet contains preliminary data, and supplementary data will be published at a later date. Fairchild Semiconductor reserves the right to make changes at any time without notice in order to improve design.
No Identification Needed	Full Production	This datasheet contains final specifications. Fairchild Semiconductor reserves the right to make changes at any time without notice in order to improve design.
Obsolete	Not In Production	This datasheet contains specifications on a product that has been discontinued by Fairchild semiconductor. The datasheet is printed for reference information only.