

3 WATT REGULATED WIDE INPUT RANGE DC/DC CONVERTER

WPC03R



FEATURES

- 1 Low Cost, High Performance
- 1 Small DIP Package
- 1 Full Power to +85°C
- 1 Extended Temperature Range: -40°C to +85°C
- 1 Industry Standard Pinouts
- 1 Full Short Circuit Protection
- 1 High Capacitive Loading Capability
- 1 Protected Against High Input Voltage

APPLICATIONS

- 1 Telecommunications
- 1 Battery Powered Systems
- 1 Portable Instruments
- 1 Transportation Equipment
- 1 Distributed Power Systems

DESCRIPTION

The WPC03R is a family of high performance DC/DC converters that offers regulated outputs over input voltage ranges of 9-18V, 18-36V and 34-72V while offering a wide operating temperature range of -40°C to +85°C without derating.

Each WPC03R contains input filtering to minimize conducted noise. The design utilizes surface mounted components, including magnetics, to provide enhanced reliability.

The converter is designed to meet the requirements of EN60950 with the "L" pinout having 1,500 VDC isolation. All WPC03R converters are designed to withstand input voltage transients to 200% of nominal input voltage. An additional feature is the ability of the WPC03R to drive high capacitive loads.

SIMPLIFIED CIRCUIT SCHEMATIC

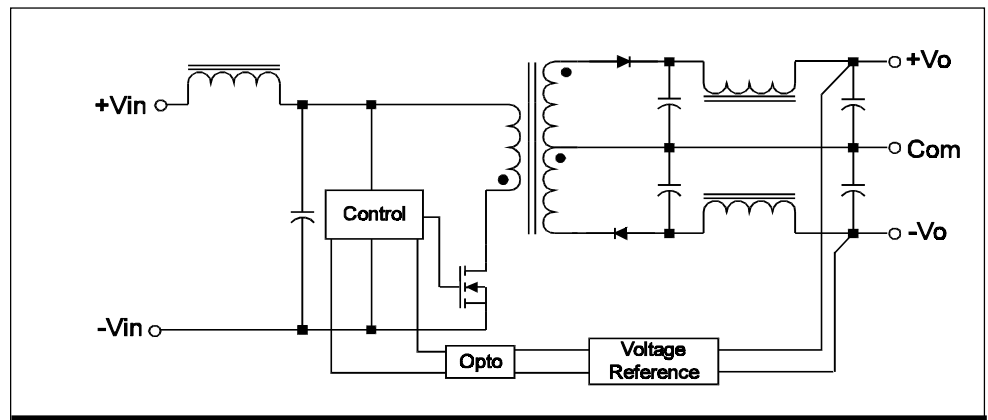

Internet: <http://www.cdpowerelectronics.com>

Power Electronics Division, United States
3400 E Britannia Drive, Tucson, Arizona 85706
Phone: 800.547.2537 Fax: 520.770.9369

Power Electronics Division, Europe
C&D Technologies (Power Electronics) Ltd.
132 Shannon Industrial Estate, Shannon, Co. Clare, Ireland
Tel: +353.61.474.133 Fax: +353.61.474.141

ABSOLUTE MAXIMUM RATINGS

Output Short Circuit Protection -----	Continuous
Internal Power Dissipation -----	1.5W
Lead Temp (soldering, 10s Max) -----	+300°C
Max Case Temperature -----	+100°C

ELECTRICAL SPECIFICATIONS

Specifications typical at $T_A = 25^\circ\text{C}$, nominal input voltage, rated output current unless otherwise stated.

Model	Nominal Input Voltage (Volts)	Rated Output Voltage (Volts)	Output Current (mA)		Max Input Current (mA) Rated Load	Max Capacitive Load (μF)	Efficiency %
			Min Load (See Note 1)	Rated Load			
WPC03R12S05	12	5.0	60	600	448	600	77
WPC03R12S12	12	12.0	24	250	445	250	80
WPC03R12S15	12	15.0	20	200	445	200	81
WPC03R12D05	12	± 5.0	± 30	± 300	470	± 300	74
WPC03R12D12	12	± 12.0	± 12	± 125	475	± 125	76
WPC03R12D15	12	± 15.0	± 10	± 100	475	± 100	77
WPC03R24S05	24	5.0	60	600	230	600	74
WPC03R24S12	24	12.0	24	250	230	250	75
WPC03R24S15	24	15.0	20	200	225	200	76
WPC03R24D05	24	± 5.0	± 30	± 300	240	± 300	73
WPC03R24D12	24	± 12.0	± 12	± 125	235	± 125	74
WPC03R24D15	24	± 15.0	± 10	± 100	230	± 100	75
WPC03R48S05	48	5.0	60	600	120	600	74
WPC03R48S12	48	12.0	24	250	118	250	75
WPC03R48S15	48	15.0	20	200	116	200	76
WPC03R48D05	48	± 5.0	± 30	± 300	120	± 300	75
WPC03R48D12	48	± 12.0	± 12	± 125	118	± 125	76
WPC03R48D15	48	± 15.0	± 10	± 100	116	± 100	77

NOTE 1: Although minimum load specifications are indicated for load measurement purposes, all models will operate under no-load conditions.

ORDERING INFORMATION

WPC03R xxyzz E
Device Family _____
Indicates wide input power 3W regulated DC/DC
Model Number _____
Selected from Table of Electrical Characteristics
xx=input voltage
y=number of outputs: S=single, D=dual
zz=output voltage
Pinout option E or L _____

COMMON SPECIFICATIONS

Specifications typical at $T_A=25^{\circ}\text{C}$, nominal input voltage, rated output current unless otherwise stated.

Parameter	Conditions	Min	Typ	Max	Units
Input					
Voltage Range		9	12	18	Vdc
		18	24	36	Vdc
		34	48	72	Vdc
Reflected Ripple Current			50		mA p-p
Isolation					
Safety Standards	Designed to meet requirements of EN60950, EN41003 & UL1950				
Rated Voltage	"L" Pinout	1500			Vdc
	"E" Pinout	1000			Vdc
Test Voltage—60 Hz, 10 secs	"L" Pinout	1500			Vpk
	"E" Pinout	1000			Vpk
Resistance			10		$\text{G}\Omega$
Capacitance			220		pF
Leakage Current	$V_{\text{iso}}=240\text{Vac}$, 60 Hz		30		μArms
Output					
Rated Power				3	W
Voltage Setpoint Accuracy				± 3.0	%
Temperature Coefficient			± 0.02		%/ $^{\circ}\text{C}$
Line Regulation-singles	Low line to high line			$\pm 1.5\%$	%
Line Regulation-duals	Low line to high line			$\pm 1.5\%$	%
Load Regulation-singles	Min load to rated load			$\pm 2\%$	%
Load Regulation-duals	Min load to rated load			$\pm 2\%$	%
Ripple & Noise	BW=5 Hz to 20 MHz		50	100	mV p-p
General					
MTTF per MIL-HDBK-217, Rev F	$T_A=25^{\circ}$		1,000,000		Hours
Temperature					
Operation		-40		+85	$^{\circ}\text{C}$
Storage		-55		+125	$^{\circ}\text{C}$

MECHANICAL SPECIFICATIONS

PINOUT “E”

Pin Number	Pin Function	
	Singles	Duals
1	+Vin	+Vin
2	No connection	-Vout
3	No connection	Common
10	-Vout	Common
11	+Vout	+Vout
12	-Vin	-Vin
13	-Vin	-Vin
14	+Vout	+Vout
15	-Vout	Common
22	No connection	Common
23	No connection	-Vout
24	+Vin	+Vin

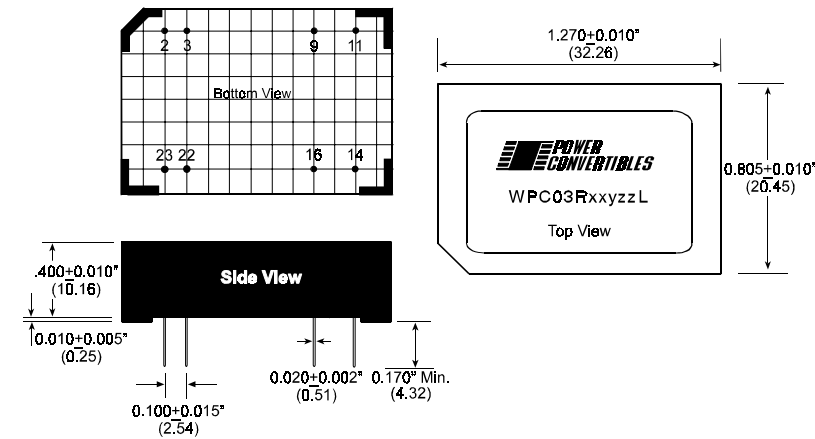
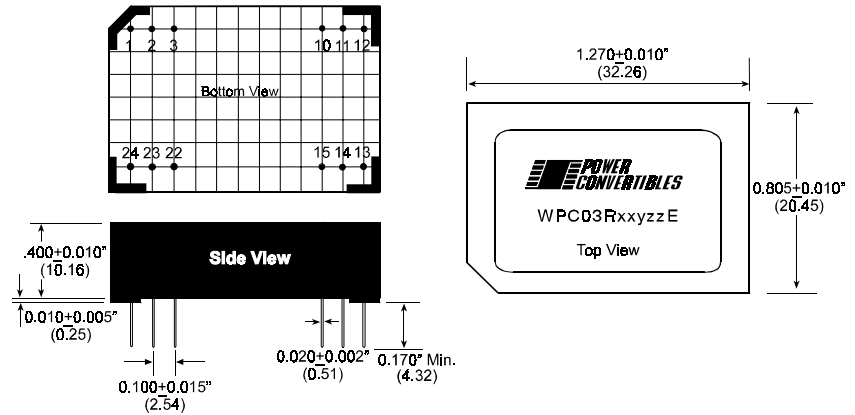

PINOUT “L”

Pin Number	Pin Function	
	Singles	Duals
2	-Vin	-Vin
3	-Vin	-Vin
9	No connection	Common
11	No connection	-Vout
14	+Vout	+Vout
16	-Vout	Common
22	+Vin	+Vin
23	+Vin	+Vin

TECHNICAL INFORMATION

Notes:

1. All dimensions in inches and (millimeters).
2. Units are encapsulated with a low thermal resistance molding compound which has excellent chemical resistance, wide operating temperature range and good electrical properties under high humidity environments. The encapsulant and outer shell have UL94V-0 ratings. Lead material is brass with a solder plated surface to allow ease of solderability.
3. GRID: 0.100 inches, (2.54 mm).
4. Pin Placement Tolerance: ± 0.015 " , ($\pm .381$ mm).

The information provided herein is believed to be reliable; however, C&D TECHNOLOGIES assumes no responsibility for inaccuracies or omissions. C&D TECHNOLOGIES assumes no responsibility for the use of this information, and all use of such information shall be entirely at the user's own risk. Prices and specifications are subject to change without notice. No patent rights or licenses to any of the circuits described herein are implied or granted to any third party. C&D TECHNOLOGIES does not authorize or warrant any C&D TECHNOLOGIES product for use in life support devices/systems or in aircraft control applications.