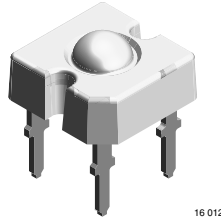

TELUX™

16 012

DESCRIPTION

The TELUX™ series is a clear, non diffused LED for high end applications where supreme luminous flux is required.

It is designed in an industry standard 7.62 mm square package utilizing highly developed InGaN technology. The supreme heat dissipation of TELUX allows applications at high ambient temperatures.

All packing units are binned for luminous flux and color to achieve best homogenous light appearance in application.

PRODUCT GROUP AND PACKAGE DATA

- Product group: LED
- Package: TELUX
- Product series: power
- Angle of half intensity: $\pm 45^\circ$

FEATURES

- Utilizing InGaN technology
- High luminous flux
- Supreme heat dissipation: R_{thJP} is 90 K/W
- High operating temperature: $T_j + 100^\circ\text{C}$
- Packed in tubes for automatic insertion
- Luminous flux and color categorized for each tube
- Small mechanical tolerances allow precise usage of external reflectors or lightguides
- Lead (Pb)-free device - RoHS compliant
- Component in accordance to RoHS 2002/95/EC and WEEE 2002/96/EC
- Compatible with wave solder processes acc. to CECC 00802 and J-STD-020C
- ESD-withstand voltage: up to 1 kV according to JESD22-A114-B
- Automotive qualified

APPLICATIONS

- Exterior lighting
- Dashboard illumination
- Tail-, stop- and turn signals of motor vehicles
- Replaces incandescent lamps

PARTS TABLE

PART	COLOR, LUMINOUS FLUX	TECHNOLOGY
VLWW9900	White, $\Phi_V > 1500$ mlm	InGaN/TAG on SiC

ABSOLUTE MAXIMUM RATINGS ¹⁾ VLWW9900

PARAMETER	TEST CONDITION	SYMBOL	VALUE	UNIT
Reverse voltage ²⁾	$I_R = 10 \mu\text{A}$	V_R	5	V
DC Forward current	$T_{amb} \leq 50^\circ\text{C}$	I_F	50	mA
Surge forward current	$t_p \leq 10 \mu\text{s}$	I_{FSM}	0.1	A
Power dissipation		P_V	255	mW
Junction temperature		T_j	100	$^\circ\text{C}$
Operating temperature range		T_{amb}	- 40 to + 100	$^\circ\text{C}$
Storage temperature range		T_{stg}	- 40 to + 100	$^\circ\text{C}$
Soldering temperature	$t \leq 5$ s, 1.5 mm from body preheat temperature $100^\circ\text{C}/30$ s	T_{sd}	260	$^\circ\text{C}$
Thermal resistance junction/ambient	with cathode heatsink of 70 mm^2	R_{thJA}	200	K/W
Thermal resistance junction/pin		R_{thJP}	90	K/W

Note:

¹⁾ $T_{amb} = 25^\circ\text{C}$, unless otherwise specified

²⁾ Driving the LED in reverse direction is suitable for a short term application

OPTICAL AND ELECTRICAL CHARACTERISTICS ¹⁾ VLWW9900, WHITE							
PARAMETER	TEST CONDITION	SYMBOL	PART	MIN.	TYP.	MAX.	UNIT
Total flux	$I_F = 50 \text{ mA}$, $R_{thJA} = 200 \text{ }^\circ\text{K/W}$	Φ_V	VLWW9900	1500	2200		mlm
Luminous intensity/total flux	$I_F = 50 \text{ mA}$, $R_{thJA} = 200 \text{ }^\circ\text{K/W}$	I_V/Φ_V			0.8		mcd/mlm
Color temperature	$I_F = 50 \text{ mA}$, $R_{thJA} = 200 \text{ }^\circ\text{K/W}$	T_K			5500		K
Angle of half intensity	$I_F = 50 \text{ mA}$, $R_{thJA} = 200 \text{ }^\circ\text{K/W}$	ϕ			± 45		deg
Total included angle	90 % of total flux captured	ϕ			75		deg
Forward voltage	$I_F = 50 \text{ mA}$, $R_{thJA} = 200 \text{ }^\circ\text{K/W}$	V_F			4.3	5.2	V
Reverse voltage	$I_R = 10 \text{ } \mu\text{A}$	V_R		5	10		V
Junction capacitance	$V_R = 0$, $f = 1 \text{ MHz}$	C_j			50		pF

Note:

¹⁾ $T_{amb} = 25 \text{ }^\circ\text{C}$, unless otherwise specified

CHROMATICITY COORDINATE CLASSIFICATION				
GROUP	X		Y	
VLWW9900	MIN.	MAX.	MIN.	MAX.
3a	0.2900	0.3025	$Y = 1.4x - 0.121$	$Y = 1.4x - 0.071$
3b	0.3025	0.3150	$Y = 1.4x - 0.121$	$Y = 1.4x - 0.071$
3c	0.2900	0.3025	$Y = 1.4x - 0.171$	$Y = 1.4x - 0.121$
3d	0.3025	0.3150	$Y = 1.4x - 0.171$	$Y = 1.4x - 0.121$
4a	0.3150	0.3275	$Y = 1.4x - 0.121$	$Y = 1.4x - 0.071$
4b	0.3275	0.3400	$Y = 1.4x - 0.121$	$Y = 1.4x - 0.071$
4c	0.3150	0.3275	$Y = 1.4x - 0.171$	$Y = 1.4x - 0.121$
4d	0.3275	0.3400	$Y = 1.4x - 0.171$	$Y = 1.4x - 0.121$
5a	0.3400	0.3525	$Y = 1.4x - 0.121$	$Y = 1.4x - 0.071$
5b	0.3525	0.3650	$Y = 1.4x - 0.121$	$Y = 1.4x - 0.071$
5c	0.3400	0.3525	$Y = 1.4x - 0.171$	$Y = 1.4x - 0.121$
5d	0.3525	0.3650	$Y = 1.4x - 0.171$	$Y = 1.4x - 0.121$

Note:

Tolerance ± 0.01

LUMINOUS FLUX CLASSIFICATION		
GROUP	LUMINOUS FLUX (MLM)	
	MIN.	MAX.
C	1500	2400
D	2000	3000
E	2500	3600
F	3000	4200

Note:

Luminous flux is tested at a current pulse duration of 25 ms and an accuracy of $\pm 11 \%$.

The above type numbers represent the order groups which include only a few brightness groups. Only one group will be shipped in one tube (there will be no mixing of two groups on each tube).

In order to ensure availability, single brightness groups will not be orderable. In a similar manner for colors where wavelength groups are measured and binned, single wavelength groups will be shipped in any one tube.

In order to ensure availability, single wavelength groups will not be orderable.

TYPICAL CHARACTERISTICS

$T_{amb} = 25\text{ }^{\circ}\text{C}$, unless otherwise specified

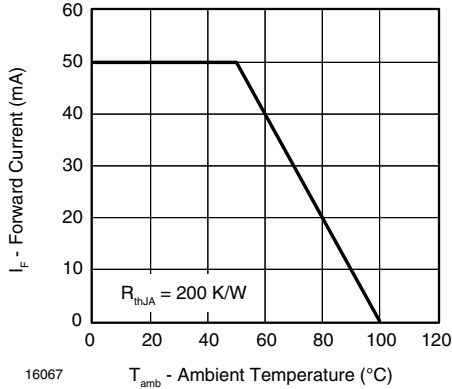

Figure 1. Forward Current vs. Ambient Temperature

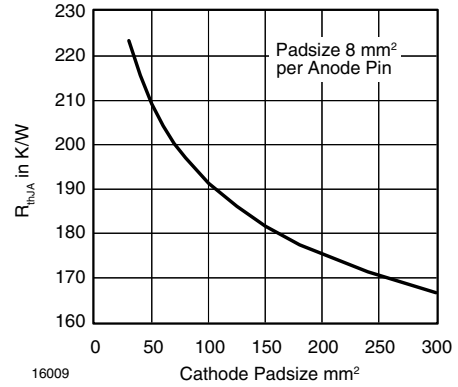

Figure 4. Thermal Resistance Junction Ambient vs. Cathode Padsize

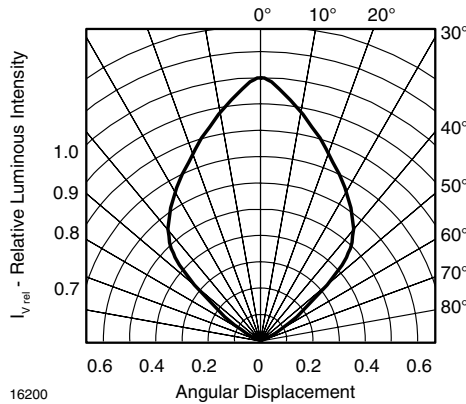

Figure 2. Rel. Luminous Intensity vs. Angular Displacement for 60° emission angle

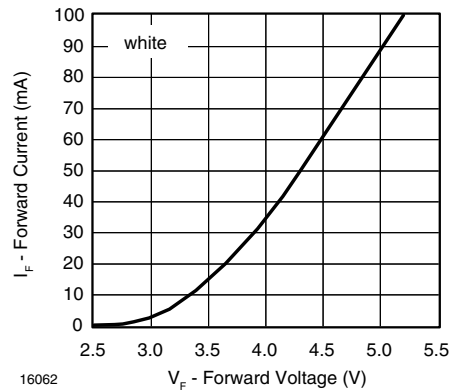

Figure 5. Forward Current vs. Forward Voltage

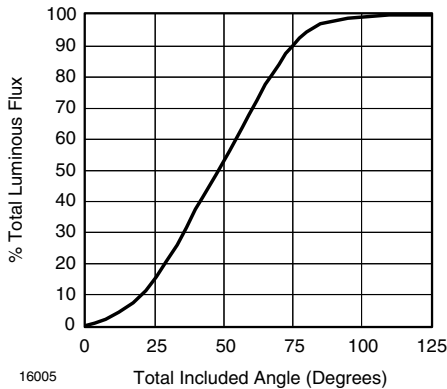

Figure 3. Percentage Total Luminous Flux vs. Total Included Angle for 60° Emission Angle

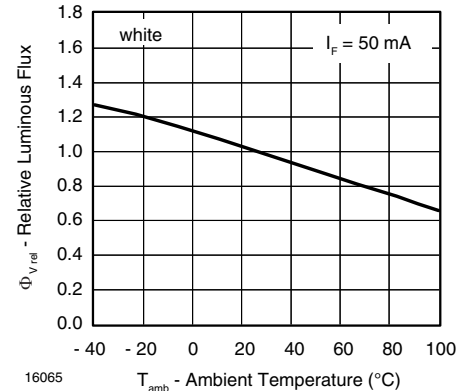

Figure 6. Rel. Luminous Flux vs. Ambient Temperature

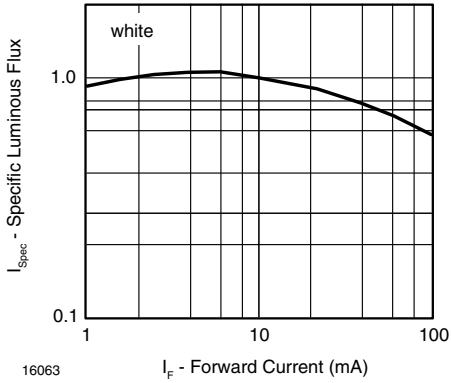

Figure 7. Specific Luminous Flux vs. Forward Current

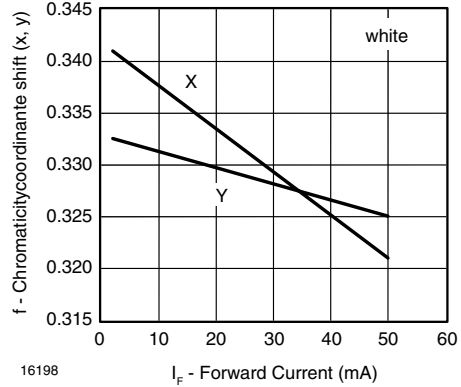

Figure 10. Chromaticity Coordinate Shift vs. Forward Current

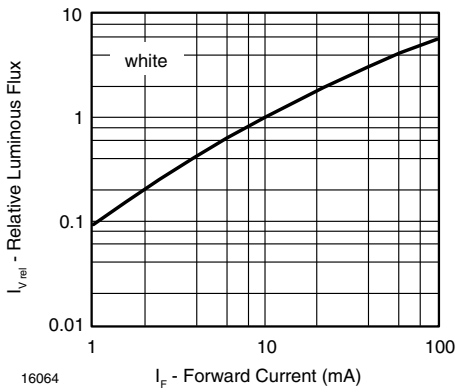

Figure 8. Relative Luminous Flux vs. Forward Current

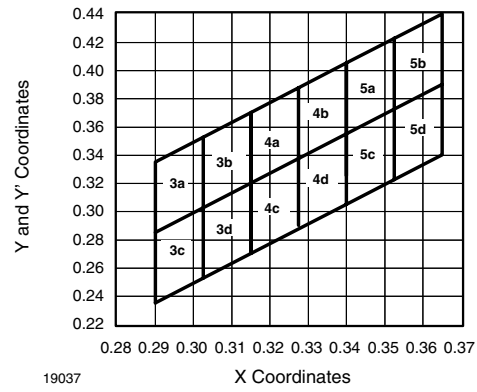

Figure 11. Coordinates of Colorgroups

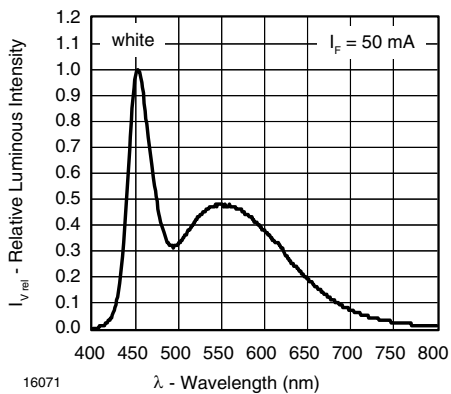
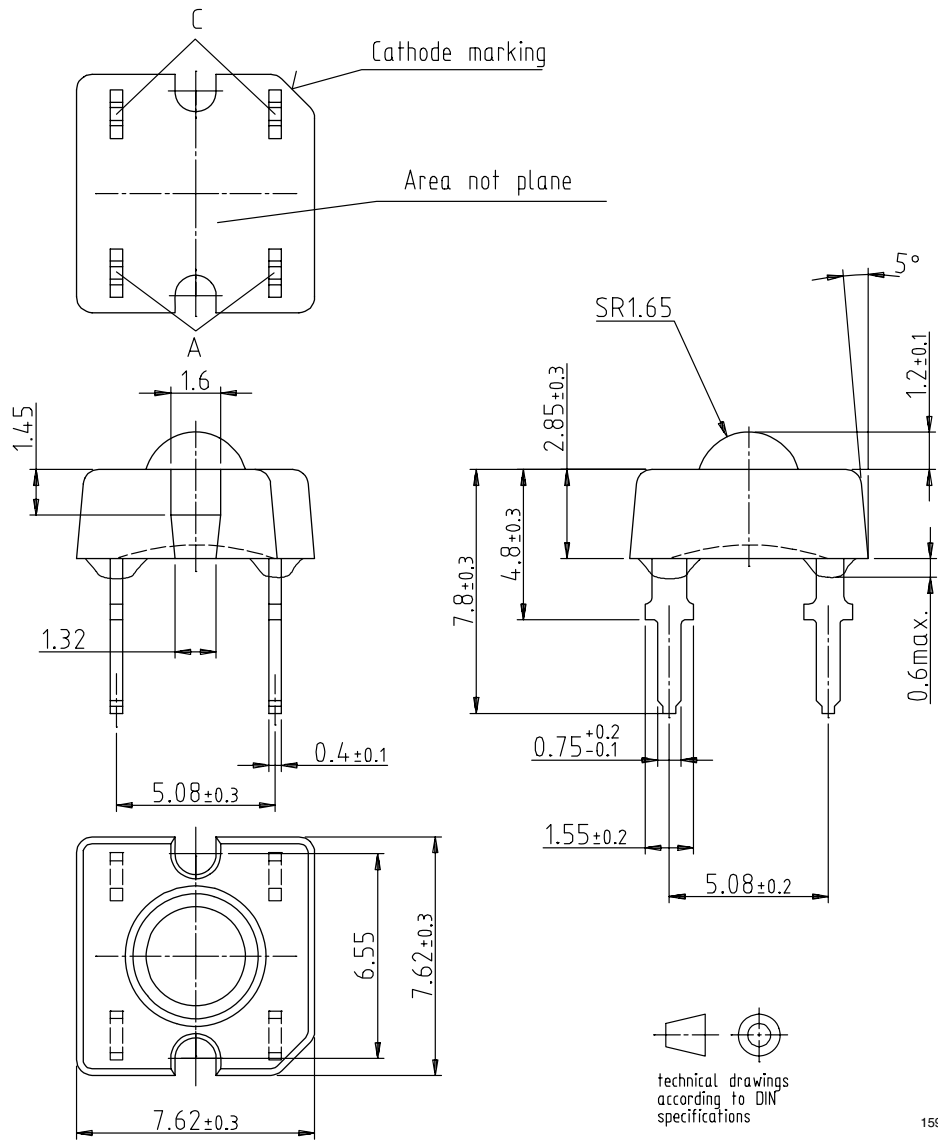

Figure 9. Relative Intensity vs. Wavelength

PACKAGE DIMENSIONS in millimeters



15984

FAN FOLD BOX Dimensions in millimeters

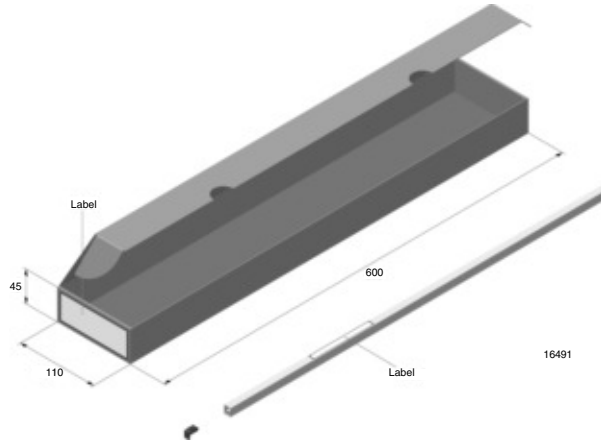

LABEL OF FAN FOLD BOX EXAMPLE:

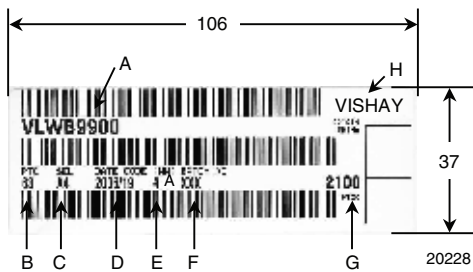

- A) Type of component
- B) Manufacturing plant
- C) SEL - selection code (bin):
e.g.: A = code for luminous intensity group
4 = code for color group
- D) Date code year/week
- E) Day code (e.g. 4: Thursday, A: early shift)
- F) Batch no.
- G) Total quantity
- H) Company code

EXAMPLE FOR TELUX TUBE LABEL Dimensions in millimeters

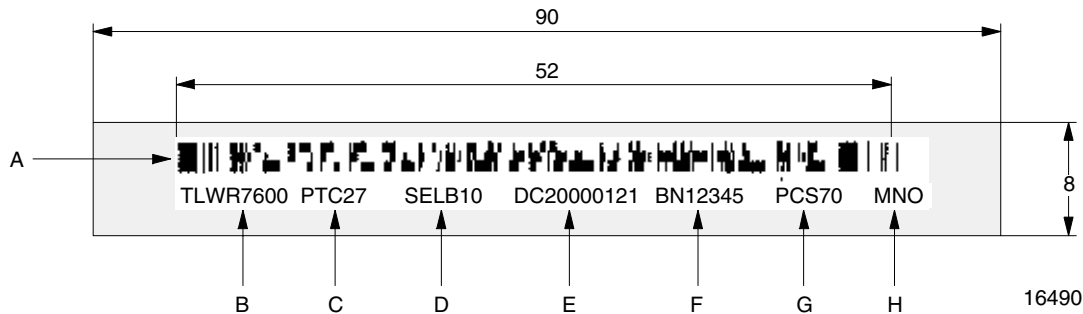

- A) Bar code
- B) Type of component
- C) Manufacturing plant
- D) SEL - selection code (bin):
Digit 1 - code for luminous flux group
Digit 2 - code for dominant wavelength group
Digit 3 - code for forward voltage group
- E) Date code
- F) Batch no.
- G) Total quantity
- H) Company code

TUBE WITH BAR CODE LABEL Dimensions in millimeters

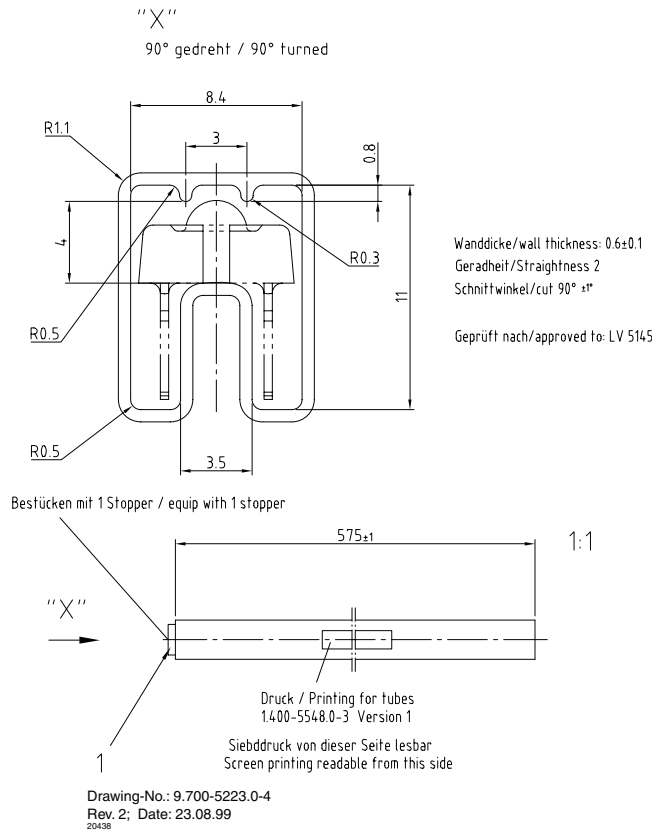

Figure 12. Drawing Proportions not scaled

Vishay Semiconductors

Ozone Depleting Substances Policy Statement

It is the policy of Vishay Semiconductor GmbH to

1. Meet all present and future national and international statutory requirements.
2. Regularly and continuously improve the performance of our products, processes, distribution and operating systems with respect to their impact on the health and safety of our employees and the public, as well as their impact on the environment.

It is particular concern to control or eliminate releases of those substances into the atmosphere which are known as ozone depleting substances (ODSs).

The Montreal Protocol (1987) and its London Amendments (1990) intend to severely restrict the use of ODSs and forbid their use within the next ten years. Various national and international initiatives are pressing for an earlier ban on these substances.

Vishay Semiconductor GmbH has been able to use its policy of continuous improvements to eliminate the use of ODSs listed in the following documents.

1. Annex A, B and list of transitional substances of the Montreal Protocol and the London Amendments respectively.
2. Class I and II ozone depleting substances in the Clean Air Act Amendments of 1990 by the Environmental Protection Agency (EPA) in the USA.
3. Council Decision 88/540/EEC and 91/690/EEC Annex A, B and C (transitional substances) respectively.

Vishay Semiconductor GmbH can certify that our semiconductors are not manufactured with ozone depleting substances and do not contain such substances.

We reserve the right to make changes to improve technical design
and may do so without further notice.

Parameters can vary in different applications. All operating parameters must be validated for each customer application by the customer. Should the buyer use Vishay Semiconductors products for any unintended or unauthorized application, the buyer shall indemnify Vishay Semiconductors against all claims, costs, damages, and expenses, arising out of, directly or indirectly, any claim of personal damage, injury or death associated with such unintended or unauthorized use.

Vishay Semiconductor GmbH, P.O.B. 3535, D-74025 Heilbronn, Germany



Disclaimer

All product specifications and data are subject to change without notice.

Vishay Intertechnology, Inc., its affiliates, agents, and employees, and all persons acting on its or their behalf (collectively, "Vishay"), disclaim any and all liability for any errors, inaccuracies or incompleteness contained herein or in any other disclosure relating to any product.

Vishay disclaims any and all liability arising out of the use or application of any product described herein or of any information provided herein to the maximum extent permitted by law. The product specifications do not expand or otherwise modify Vishay's terms and conditions of purchase, including but not limited to the warranty expressed therein, which apply to these products.

No license, express or implied, by estoppel or otherwise, to any intellectual property rights is granted by this document or by any conduct of Vishay.

The products shown herein are not designed for use in medical, life-saving, or life-sustaining applications unless otherwise expressly indicated. Customers using or selling Vishay products not expressly indicated for use in such applications do so entirely at their own risk and agree to fully indemnify Vishay for any damages arising or resulting from such use or sale. Please contact authorized Vishay personnel to obtain written terms and conditions regarding products designed for such applications.

Product names and markings noted herein may be trademarks of their respective owners.