



PDA ANALOG INTERFACE CIRCUIT

FEATURES

- 4-WIRE TOUCH SCREEN INTERFACE
- RATIOMETRIC CONVERSION
- SINGLE 2.7V TO 3.6V SUPPLY
- SERIAL INTERFACE
- INTERNAL DETECTION OF SCREEN TOUCH
- PROGRAMMABLE 8-, 10-, OR 12-BIT RESOLUTION
- PROGRAMMABLE SAMPLING RATES
- DIRECT BATTERY MEASUREMENT (0.5V to 6V)
- ON-CHIP TEMPERATURE MEASUREMENT
- TOUCH-PRESSURE MEASUREMENT
- FULL POWER-DOWN CONTROL
- TSSOP-20 PACKAGE

APPLICATIONS

- PERSONAL DIGITAL ASSISTANTS
- CELLULAR PHONES
- MP3 PLAYERS

DESCRIPTION

The TSC2000 is a complete PDA analog interface circuit. It contains a complete 12-bit, Analog-to-Digital (A/D) resistive touch screen converter including drivers, the control to measure touch pressure, and an 8-bit Digital-to-Analog (D/A) converter output for LCD contrast control. The TSC2000 interfaces to the host controller through a standard SPI™ serial interface. The TSC2000 offers programmable resolution and sampling rates from 8- to 12-bits and up to 125kHz to accommodate different screen sizes.

The TSC2000 also offers two battery-measurement inputs, one of which is capable of reading battery voltages up to 6V while operating at only 2.7V. It also has an on-chip temperature sensor capable of reading 0.3°C resolution. The TSC2000 is available in a TSSOP-20 package.

SPI is a registered trademark of Motorola.
US Patent No. 624639.

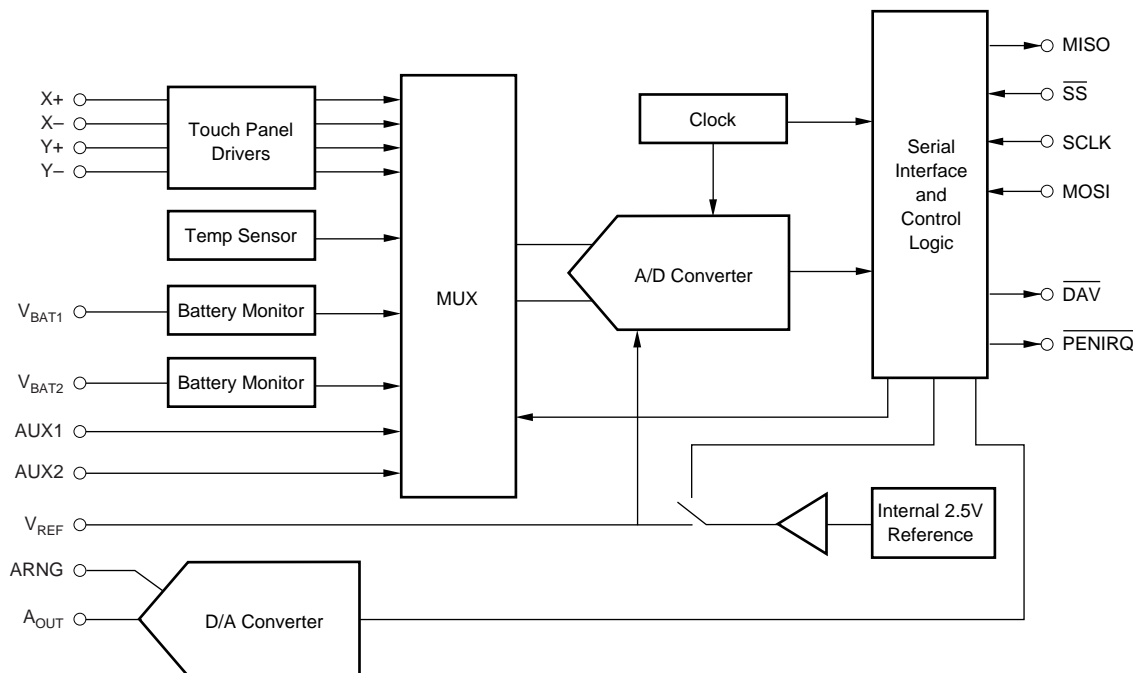

Please be aware that an important notice concerning availability, standard warranty, and use in critical applications of Texas Instruments semiconductor products and disclaimers thereto appears at the end of this data sheet.

ABSOLUTE MAXIMUM RATINGS⁽¹⁾

| | |
|---|--|
| V _{DD} to GND | -0.3V to +6V |
| Digital Input Voltage to GND | -0.3V to V _{DD} + 0.3V |
| Operating Temperature Range | -40°C to +105°C |
| Storage Temperature Range | -65°C to +150°C |
| Junction Temperature (T _J Max) | +150°C |
| TSSOP Package | |
| Power Dissipation | (T _J Max - T _A)/θ _{JA} |
| θ _{JA} Thermal Impedance | 93°C/W |
| Lead Temperature, Soldering | |
| Vapor Phase (60s) | +215°C |
| Infrared (15s) | +220°C |

NOTE: (1) Stresses above those listed under "Absolute Maximum Ratings" may cause permanent damage to the device. Exposure to absolute maximum conditions for extended periods may affect device reliability.



ELECTROSTATIC DISCHARGE SENSITIVITY

This integrated circuit can be damaged by ESD. Texas Instruments recommends that all integrated circuits be handled with appropriate precautions. Failure to observe proper handling and installation procedures can cause damage.

ESD damage can range from subtle performance degradation to complete device failure. Precision integrated circuits may be more susceptible to damage because very small parametric changes could cause the device not to meet its published specifications.

| PRODUCT | INTEGRAL LINEARITY ERROR (LSB) | PACKAGE-LEAD | PACKAGE DESIGNATOR ⁽¹⁾ | SPECIFIED TEMPERATURE RANGE | PACKAGE MARKING | ORDERING NUMBER ⁽²⁾ | TRANSPORT MEDIA, QUANTITY |
|------------|--------------------------------|--------------|-----------------------------------|-----------------------------|-----------------|--------------------------------|---------------------------|
| TSC2000IPW | ±2 | TSSOP-20 | PW | -40°C to +85°C | TSC2000I | TSC2000IPW | Rails, 70 |
| " | " | " | " | " | " | TSC2000IPWR | Tape and Reel, 2000 |

NOTES: (1) For the most current specifications and package information, refer to our web site at www.ti.com. (2) Models labeled with "R" indicates large quantity tape and reel.

PIN CONFIGURATION

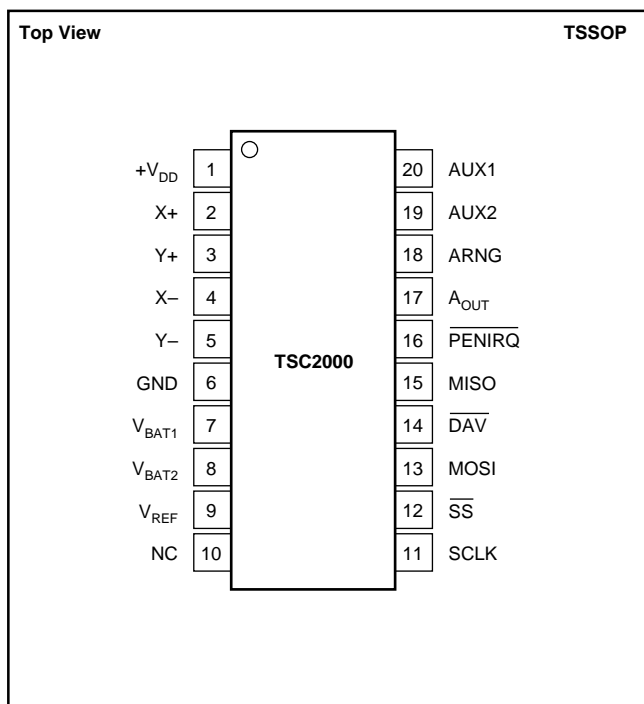

PIN DESCRIPTION

| PIN | NAME | DESCRIPTION |
|-----|-------------------|---|
| 1 | V _{DD} | Power Supply |
| 2 | X+ | X+ Position Input |
| 3 | Y+ | Y+ Position Input |
| 4 | X- | X- Position Input |
| 5 | Y- | Y- Position Input |
| 6 | GND | Ground |
| 7 | V _{BAT1} | Battery Monitor Input 1 |
| 8 | V _{BAT2} | Battery Monitor Input 2 |
| 9 | V _{REF} | Voltage Reference Input/Output |
| 10 | NC | No Connection |
| 11 | SCLK | Serial Clock Input |
| 12 | SS | Slave Select Input (Active LOW). Data will not be clocked in to MOSI unless SS is LOW. When SS is HIGH, MISO is high impedance. |
| 13 | MOSI | Serial Data Input. Data is clocked in at SCLK falling edge. |
| 14 | DAV | Data Available (Active LOW) |
| 15 | MISO | Serial Data Output. Data is clocked out at SCLK falling edge. High impedance when SS is HIGH. |
| 16 | PENIRQ | Pen Interrupt |
| 17 | A _{OUT} | Analog Output Current from D/A Converter |
| 18 | ARNG | D/A Converter Analog Output Range Set |
| 19 | AUX2 | Auxiliary A/D Converter Input 2 |
| 20 | AUX1 | Auxiliary A/D Converter Input 1 |

ELECTRICAL CHARACTERISTICS

At -40°C to $+85^{\circ}\text{C}$, $+V_{\text{DD}} = +2.7\text{V}$, internal $V_{\text{REF}} = +2.5\text{V}$, conversion clock = 2MHz, 12-bit mode, unless otherwise noted.

| PARAMETER | CONDITIONS | TSC2000IPW | | | UNITS |
|---|--|--|-----------------------------|--------------------------------------|--|
| | | MIN | TYP | MAX | |
| AUXILIARY ANALOG INPUT Input Voltage Range Input Capacitance Input Leakage Current | | 0 | 25 ± 1 | $+V_{\text{REF}}$ | V pF μA |
| BATTERY MONITOR INPUT Input Voltage Range Input Voltage Range Input Capacitance Input Leakage Current Accuracy | VBAT1 VBAT2 | 0.5 0.5 | 25 ± 1 | 6.0 3.0 | V V pF μA % |
| TEMPERATURE MEASUREMENT Temperature Range Temperature Resolution Accuracy | | -40 | 0.3 ± 2 | $+85$ | $^{\circ}\text{C}$ $^{\circ}\text{C}$ $^{\circ}\text{C}$ |
| A/D CONVERTER Resolution No Missing Codes Integral Linearity Offset Error Gain Error Noise Power-Supply Rejection | Programmable: 8-, 10-, or 12-Bits 12-Bit Resolution Excluding Reference Error | 11 | | 12 ± 2 ± 6 ± 6 | Bits Bits LSB LSB LSB μVrms dB |
| D/A CONVERTER Output Current Range Resolution Integral Linearity | Set by Resistor from ARNG to GND | 650 | ± 2 | 8 | μA Bits LSB |
| VOLTAGE REFERENCE Voltage Range Reference Drift External Reference Input Range Current Drain | Internal 2.5V Internal 1.25V External Reference | 2.45 1.225 1.0 | 2.5 1.25 20 20 | 2.55 1.275 V_{DD} | V V ppm/ $^{\circ}\text{C}$ V μA |
| DIGITAL INPUT/OUTPUT Internal Clock Frequency Logic Family Logic Levels: V_{IH} V_{IL} V_{OH} V_{OL} | $I_{\text{IH}} = +5\mu\text{A}$ $I_{\text{IL}} = +5\mu\text{A}$ $I_{\text{OH}} = 2$ TTL Loads $I_{\text{OL}} = 2$ TTL Loads | $0.7V_{\text{DD}}$ -0.3 $0.8V_{\text{DD}}$ | 8 CMOS | $0.3V_{\text{DD}}$ 0.4 | MHz V V V V |
| POWER-SUPPLY REQUIREMENTS Power-Supply Voltage, $+V_{\text{DD}}$ Quiescent Current | Specified Performance See Note (1) See Note (2) Power Down | 2.7 | 1.25 500 | 3.6 2.3 3 | V mA μA μA |
| TEMPERATURE RANGE Specified Performance | | -40 | | $+85$ | $^{\circ}\text{C}$ |

NOTES: (1) AUX1 conversion, no averaging, no REF power down, 50 μs conversion. (2) AUX1 conversion, no averaging, external reference, 50 μs conversion.

TIMING CHARACTERISTICS⁽¹⁾⁽²⁾

At -40°C to $+85^{\circ}\text{C}$, $+V_{\text{DD}} = +2.7\text{V}$, $V_{\text{REF}} = +2.5\text{V}$, unless otherwise noted.

| PARAMETER | CONDITIONS | TSC2000 | | | UNITS |
|-------------------------------------|-------------------|---------|-----|-----|-------|
| | | MIN | TYP | MAX | |
| SCLK Period | t_{sck} | 30 | | | ns |
| Enable Lead Time | t_{Lead} | 15 | | | ns |
| Enable Lag Time | t_{Lag} | 15 | | | ns |
| Sequential Transfer Delay | t_{id} | 30 | | | ns |
| Data Setup Time | t_{su} | 10 | | | ns |
| Data Hold Time (inputs) | t_{hi} | 10 | | | ns |
| Data Hold Time (outputs) | t_{ho} | 0 | | | ns |
| Slave Access Time | t_{a} | | | 15 | ns |
| Slave D_{OUT} Disable Time | t_{dis} | | | 15 | ns |
| DataValid | t_{v} | | | 10 | ns |
| Rise Time | t_{r} | | | 30 | ns |
| Fall Time | t_{f} | | | 30 | ns |

NOTES: (1) All input signals are specified with $t_{\text{r}} = t_{\text{f}} = 5\text{ns}$ (10% to 90% of V_{DD}) and timed from a voltage level of $(V_{\text{IL}} + V_{\text{IH}})/2$. (2) See timing diagram below.

TIMING DIAGRAM

All specifications typical at -40°C to $+85^{\circ}\text{C}$, $+V_{\text{DD}} = +2.7\text{V}$.

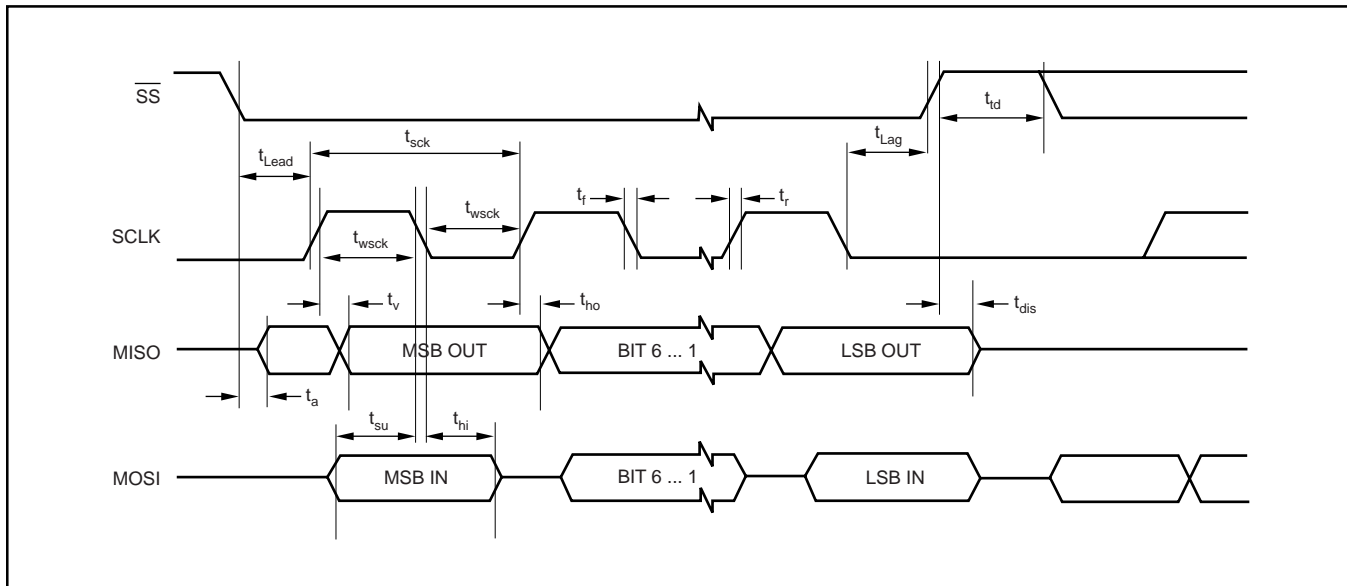

TYPICAL CHARACTERISTICS

At $T_A = +25^\circ\text{C}$, $+V_{DD} = +2.7\text{V}$, conversion clock = 2MHz, 12-bit mode. Internal $V_{REF} = +2.5\text{V}$, unless otherwise noted.

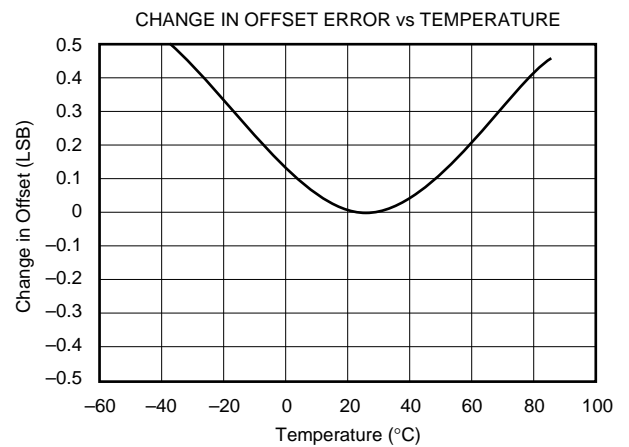
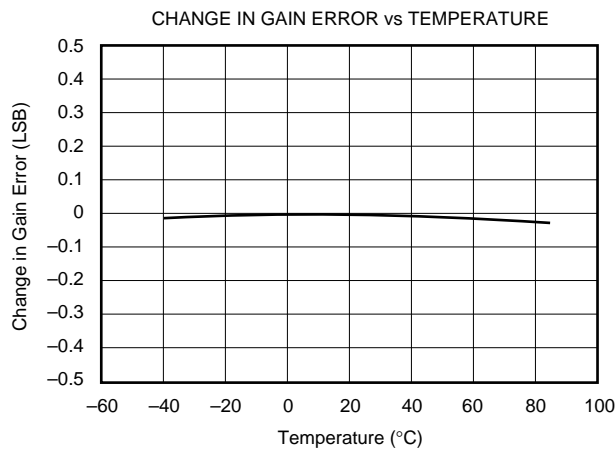
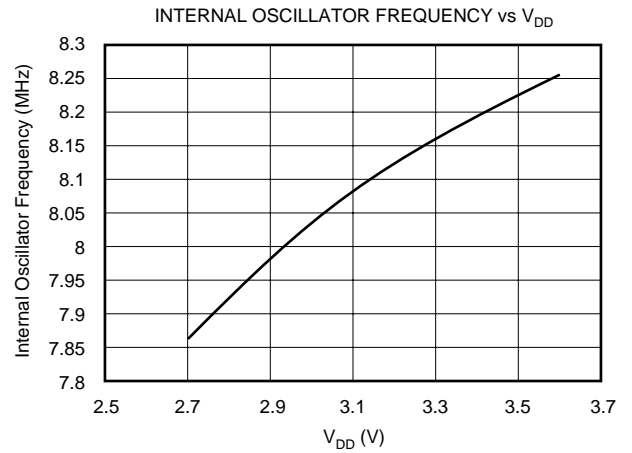
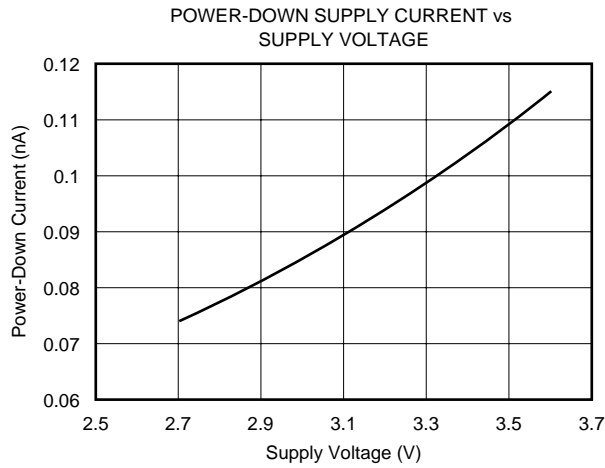
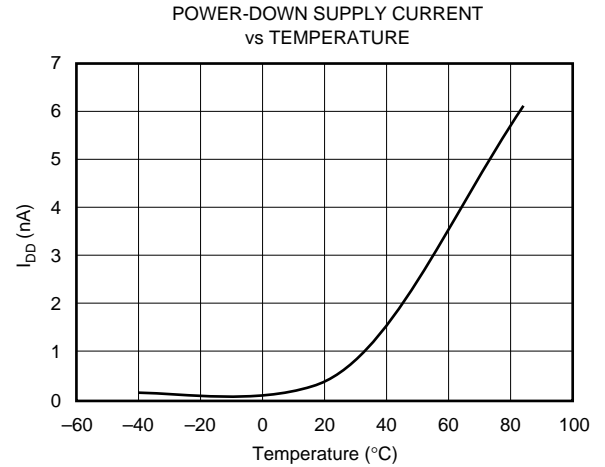
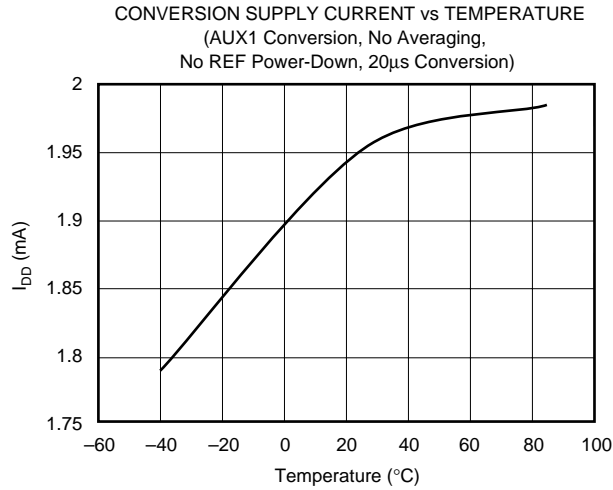

TYPICAL CHARACTERISTICS (Cont.)

At $T_A = +25^\circ\text{C}$, $+V_{DD} = +2.7\text{V}$, conversion clock = 2MHz, 12-bit mode. Internal $V_{REF} = +2.5\text{V}$, unless otherwise noted.

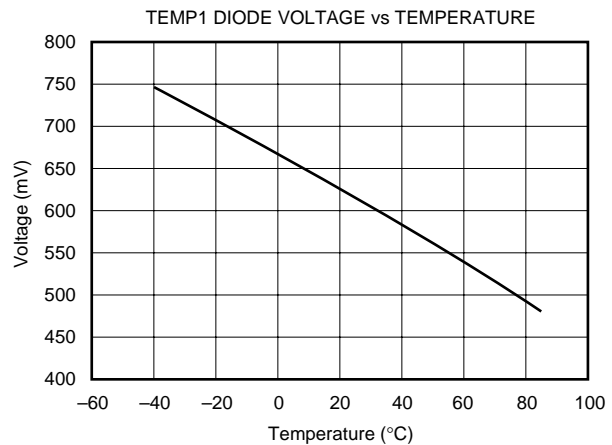
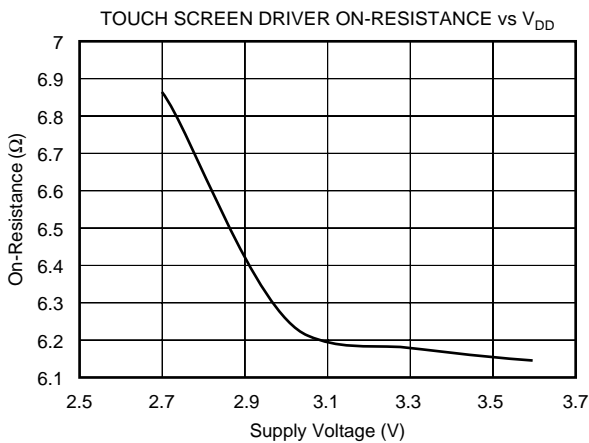
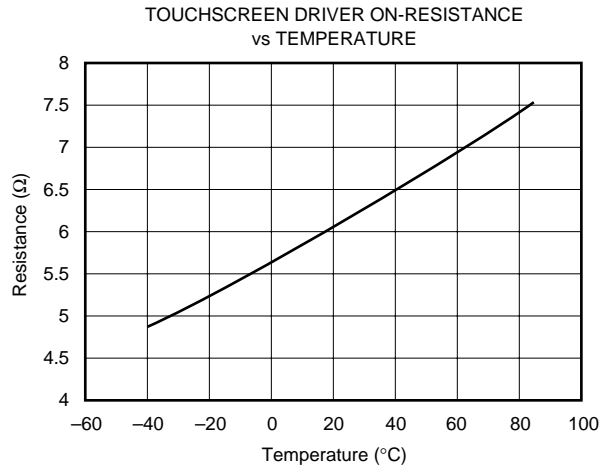
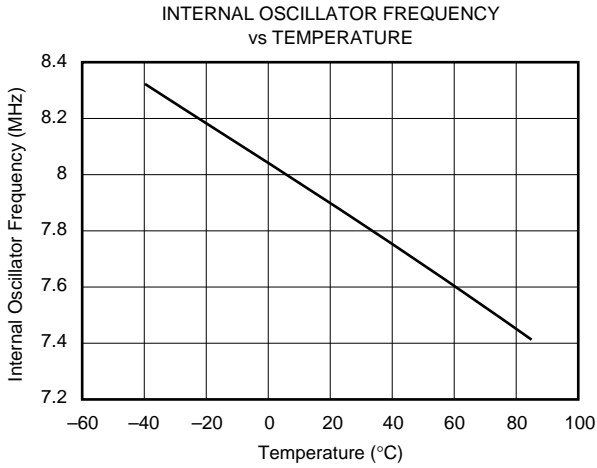
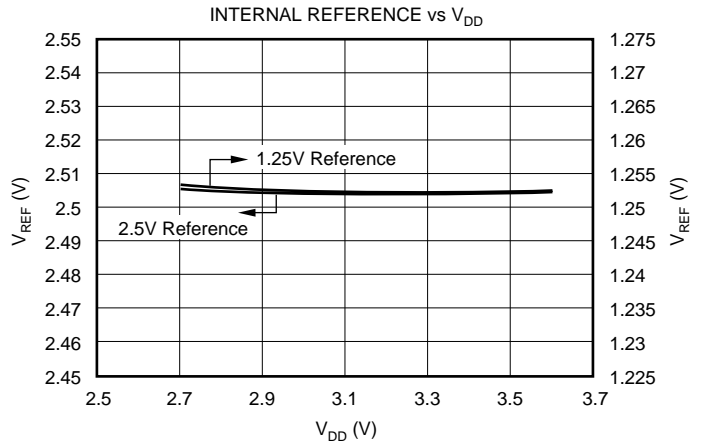
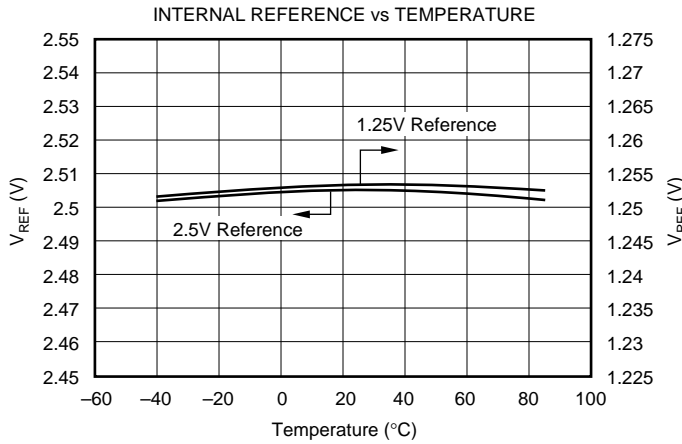

TYPICAL CHARACTERISTICS (Cont.)

At $T_A = +25^\circ\text{C}$, $+V_{DD} = +2.7\text{V}$, conversion clock = 2MHz, 12-bit mode. Internal $V_{REF} = +2.5\text{V}$, unless otherwise noted.

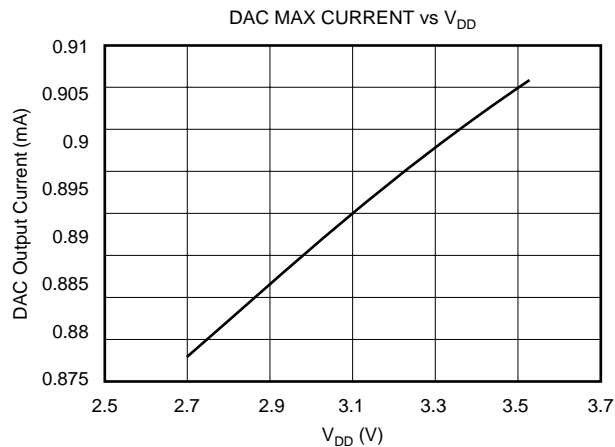
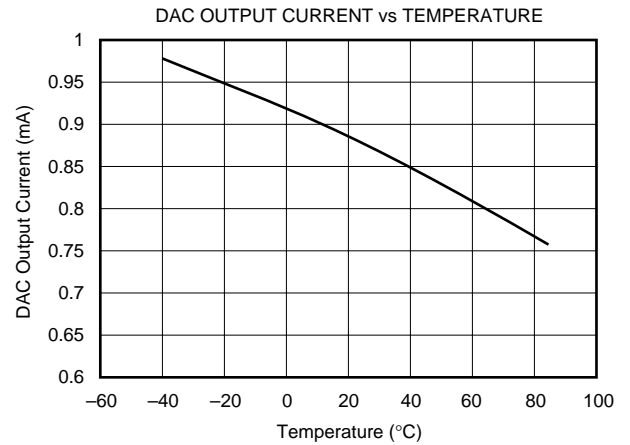
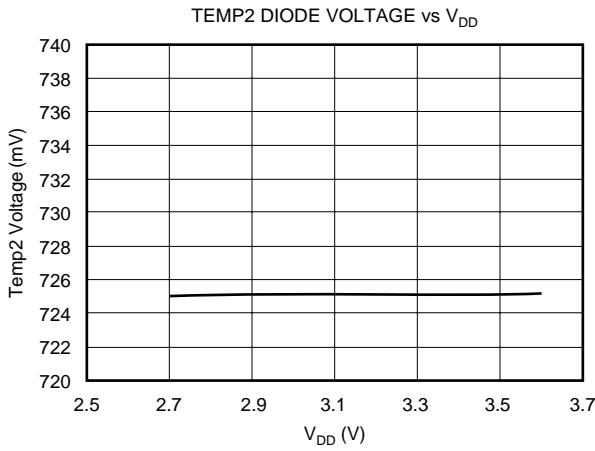
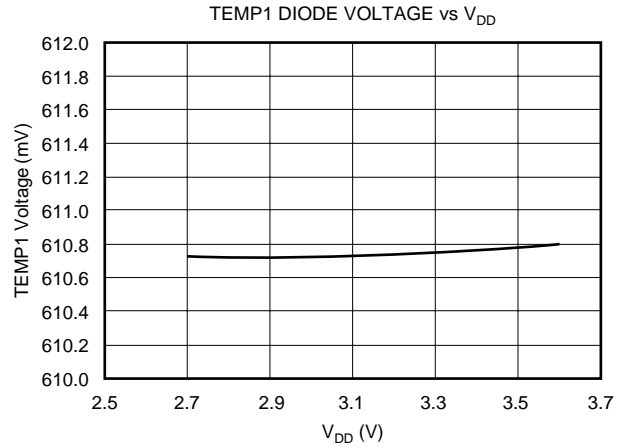
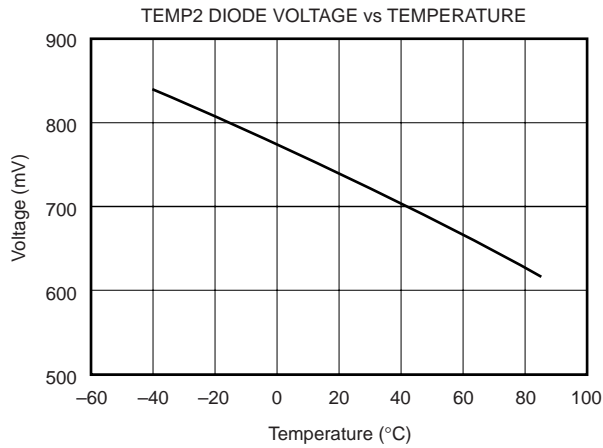

OVERVIEW

The TSC2000 is an analog interface circuit for human interface devices. A register-based architecture eases integration with microprocessor-based systems through a standard SPI bus. All peripheral functions are controlled through the registers and onboard state machines.

The TSC2000 consists of the following blocks (refer to the block diagram on the front page):

- Touch Screen Interface
- Battery Monitors
- Auxiliary Inputs
- Temperature Monitor
- Current Output D/A Converter

Communication to the TSC2000 is via a standard SPI serial interface. This interface requires that the Slave Select signal be driven LOW to communicate with the TSC2000. Data is then shifted into or out of the TSC2000 under control of the host microprocessor, which also provides the serial data clock.

Control of the TSC2000 and its functions is accomplished by writing to different registers in the TSC2000. A simple command protocol is used to address the 16-bit registers. Registers control the operation of the A/D converter and D/A converter.

The result of measurements made will be placed in the TSC2000's memory map and may be read by the host at any time. Three signals are available from the TSC2000 to indicate that data is available for the host to read. The \overline{DAV} output indicates that an A/D conversion has completed and that data is available. The \overline{PENIRQ} output indicates that a touch has been detected on the touch screen. A typical application of the TSC2000 is shown in Figure 1.

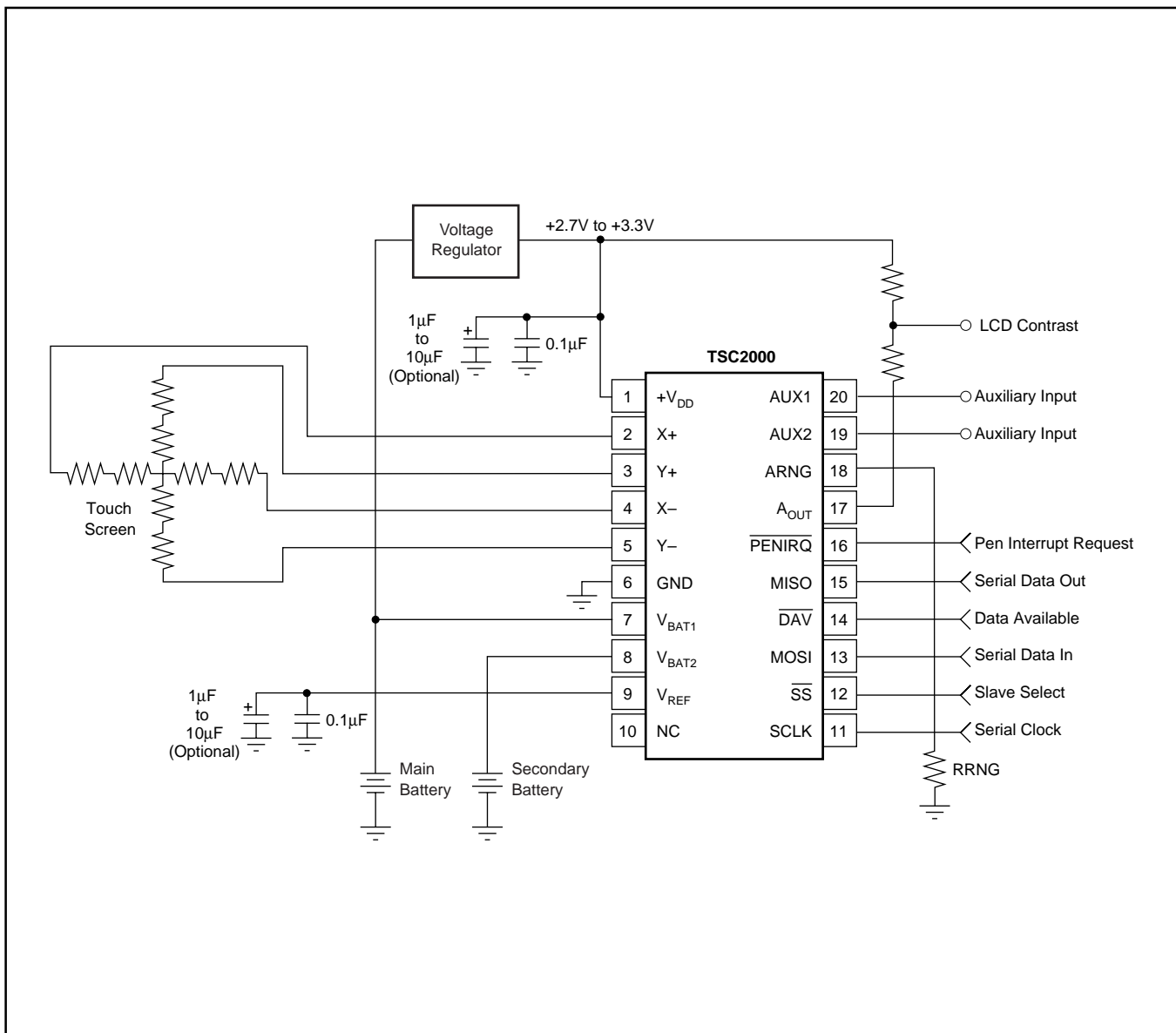

FIGURE 1. Typical Circuit Configuration.

OPERATION—TOUCH SCREEN

A resistive touch screen works by applying a voltage across a resistor network and measuring the change in resistance at a given point on the matrix where a screen is touched by an input stylus, pen, or finger. The change in the resistance ratio marks the location on the touch screen.

The TSC2000 supports the resistive 4-wire configurations (see Figure 1). The circuit determines location in two coordinate pair dimensions, although a third dimension can be added for measuring pressure.

THE 4-WIRE TOUCH SCREEN COORDINATE PAIR MEASUREMENT

A 4-wire touch screen is constructed as shown in Figure 2. It consists of two transparent resistive layers separated by insulating spacers.

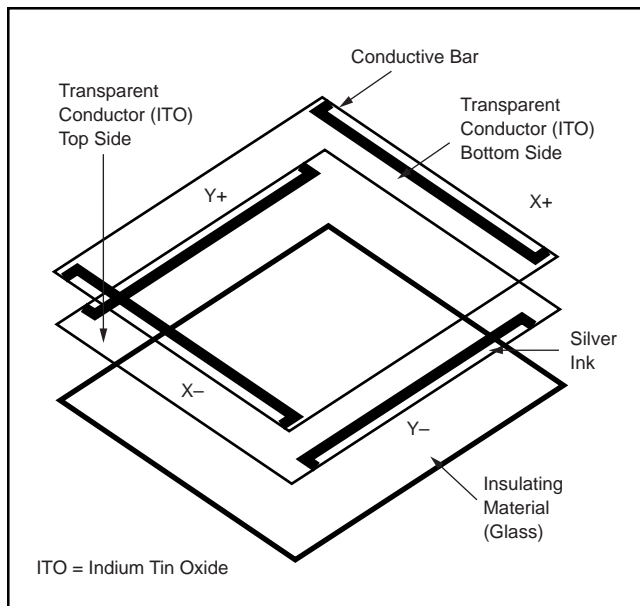

FIGURE 2. 4-Wire Touch Screen Construction.

The 4-wire touch screen panel works by applying a voltage across the vertical or horizontal resistive network. The A/D converter converts the voltage measured at the point the panel is touched. A measurement of the Y-position of the pointing device is made by connecting the X+ input to a data converter chip, turning on the Y+ and Y- drivers, and digitizing the voltage seen at the X+ input. The voltage measured is determined by the voltage divider developed at the point of touch. For this measurement, the horizontal panel resistance in the X+ lead does not affect the conversion due to the high input impedance of the A/D converter. Voltage is then applied to the other axis, and the A/D converter converts the voltage representing the X-position on the screen. This provides the X- and Y-coordinates to the associated processor.

Measuring touch pressure (Z) can also be done with the TSC2000. To determine pen or finger touch, the pressure of the “touch” needs to be determined. Generally, it is not necessary to have very high performance for this test, there-

fore, the 8-bit resolution mode is recommended (however, calculations will be shown with the 12-bit resolution mode). There are several different ways of performing this measurement. The TSC2000 supports two methods. The first method requires knowing the X-plate resistance, measurement of the X-position, and two additional cross panel measurements (Z_2 and Z_1) of the touch screen, as seen in Figure 3. Using Equation 1 will calculate the touch resistance:

$$R_{\text{TOUCH}} = R_{\text{X-Plate}} \cdot \frac{\text{X-Position}}{4096} \left(\frac{Z_2}{Z_1} - 1 \right) \quad (1)$$

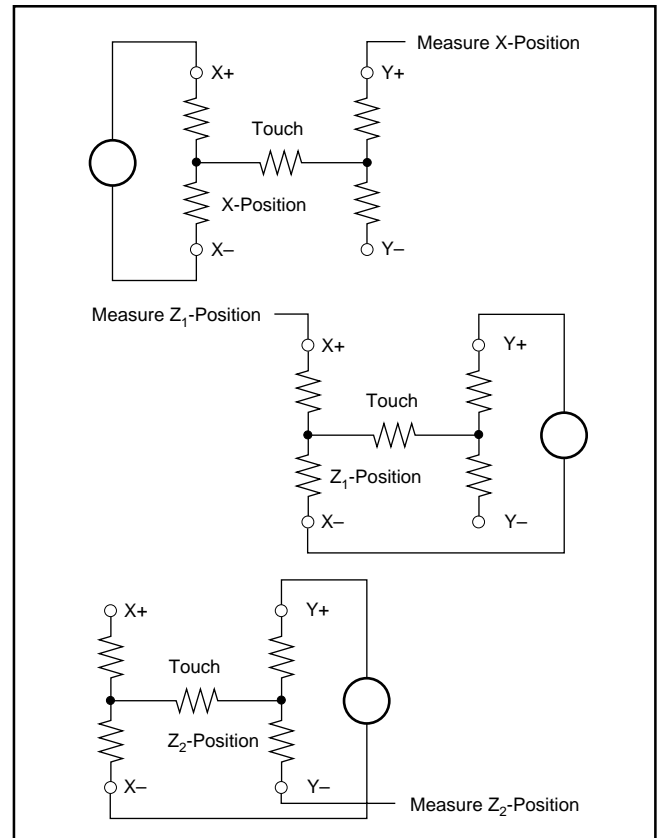

FIGURE 3. Pressure Measurement.

The second method requires knowing both the X-plate and Y-plate resistance, measurement of X-position and Y-position, and Z_1 . Using Equation 2 will also calculate the touch resistance:

$$R_{\text{TOUCH}} = R_{\text{X-Plate}} \cdot \frac{\text{X-Position}}{4096} \left(\frac{4096}{Z_1} - 1 \right) - R_{\text{Y-Plate}} \cdot \frac{\text{Y-Position}}{4096} \quad (2)$$

When the touch panel is pressed or touched, and the drivers to the panel are turned on, the voltage across the touch panel will often overshoot and then slowly settle (decay) down to a stable DC value. This is due to mechanical bouncing which is caused by vibration of the top layer sheet of the touch panel when the panel is pressed. This settling time must be accounted for, or else the converted value will be in error. Therefore, a delay must be introduced between the time the driver for a particular measurement is turned on, and the time measurement is made.

In some applications, external capacitors may be required across the touch screen for filtering noise picked up by the touch screen; i.e., noise generated by the LCD panel or back-light circuitry. The value of these capacitors will provide a low-pass filter to reduce the noise, but will cause an additional settling time requirement when the panel is touched.

Several solutions to this problem are available in the TSC2000. A programmable delay time is available which sets the delay between turning the drivers on and making a conversion. This is referred to as the Panel Voltage Stabilization time, and is used in some of the modes available in the TSC2000. In other modes, the TSC2000 can be commanded to turn on the drivers only without performing a conversion. Time can then be allowed before a conversion is started.

The TSC2000 touch screen interface can measure position (X and Y) and pressure (Z). Determination of these coordinates is possible under three different modes of the A/D converter: conversion controlled by the TSC2000, initiated by detection of a touch; conversion controlled by the TSC2000, initiated by the host responding to the $\overline{\text{PENIRQ}}$ signal; or conversion completely controlled by the host processor.

A/D CONVERTER

The analog inputs of the TSC2000 are shown in Figure 4. The analog inputs (X, Y, and Z touch panel coordinates, battery voltage monitors, chip temperature, and auxiliary inputs) are provided via a multiplexer to the Successive Approximation Register (SAR) A/D converter. The A/D converter architecture is based on capacitive redistribution architecture which inherently includes a sample-and-hold function.

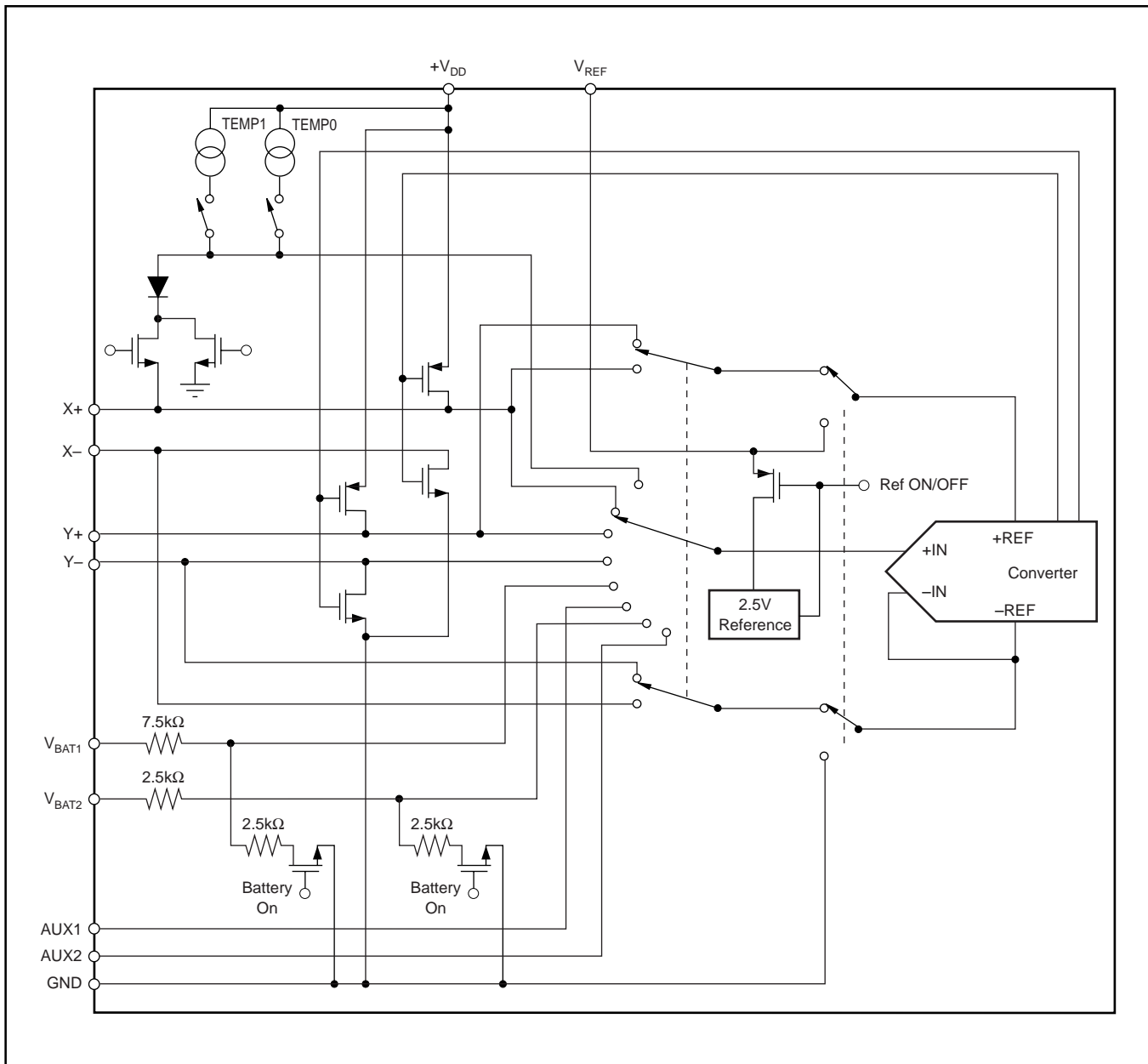

FIGURE 4. Simplified Diagram of the Analog Input Section.

A unique configuration of low on-resistance switches allows an unselected A/D converter input channel to provide power and an accompanying pin to provide ground for driving the touch panel. By maintaining a differential input to the converter and a differential reference input architecture, it is possible to negate errors caused by the driver switch on-resistances.

The A/D converter is controlled by an A/D Converter Control Register. Several modes of operation are possible, depending upon the bits set in the control register. Channel selection, scan operation, averaging, resolution, and conversion rate may all be programmed through this register. These modes are outlined in the sections below for each type of analog input. The results of conversions made are stored in the appropriate result register.

Data Format

The TSC2000 output data is in Straight Binary format, as shown in Figure 5. This figure shows the ideal output code for the given input voltage and does not include the effects of offset, gain, or noise.

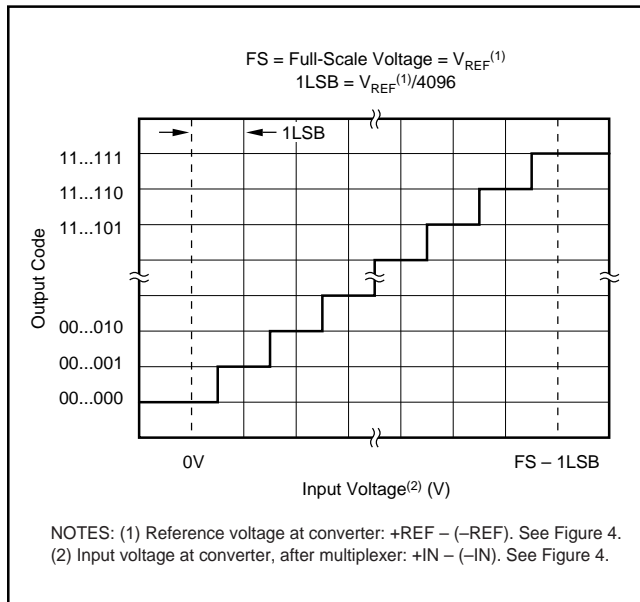

FIGURE 5. Ideal Input Voltages and Output Codes.

Reference

The TSC2000 has an internal voltage reference that can be set to 1.25V or 2.5V, through the Reference Control Register. The internal reference voltage is only used in the single-ended mode for battery monitoring, temperature measurement, and for utilizing the auxiliary inputs. Optimal touch screen performance is achieved when using a ratiometric conversion, thus all touch screen measurements are done automatically in the differential mode. An external reference can also be applied to the V_{REF} pin, and the internal reference can be turned off.

Variable Resolution

The TSC2000 provides three different resolutions for the A/D converter: 8-, 10-, or 12-bits. Lower resolutions are often practical for measurements such as touch pressure. Perform-

ing the conversions at lower resolutions reduces the amount of time it takes for the A/D converter to complete its conversion process, which lowers power consumption.

Conversion Clock and Conversion Time

The TSC2000 contains an internal 8MHz clock, which is used to drive the state machines inside the device that perform the many functions of the part. This clock is divided down to provide a clock to run the A/D converter. The division ratio for this clock is set in the A/D Converter Control Register. The ability to change the conversion clock rate allows the user to choose the optimal value for resolution, speed, and power. If the 8MHz clock is used directly, the A/D converter is limited to 8-bit resolution; using higher resolutions at this speed will not result in accurate conversions. Using a 4MHz conversion clock is suitable for 10-bit resolution; 12-bit resolution requires that the conversion clock run at 1MHz or 2MHz.

Regardless of the conversion clock speed, the internal clock will run nominally at 8MHz. The conversion time of the TSC2000 is dependent upon several functions. While the conversion clock speed plays an important role in the time it takes for a conversion to complete, a certain number of internal clock cycles is needed for proper sampling of the signal. Moreover, additional times, such as the Panel Voltage Stabilization time, can add significantly to the time it takes to perform a conversion. Conversion time can vary depending upon the mode in which the TSC2000 is used. Throughout this data sheet, internal and conversion clock cycles will be used to describe the times that many functions take. In considering the total system design, these times must be taken into account by the user.

Touch Detect

The pen interrupt (\overline{PENIRQ}) output function is detailed in Figure 6. While in the power-down mode, the Y- driver is ON and connected to GND and the \overline{PENIRQ} output is connected to the X+ input. When the panel is touched, the X+ input is

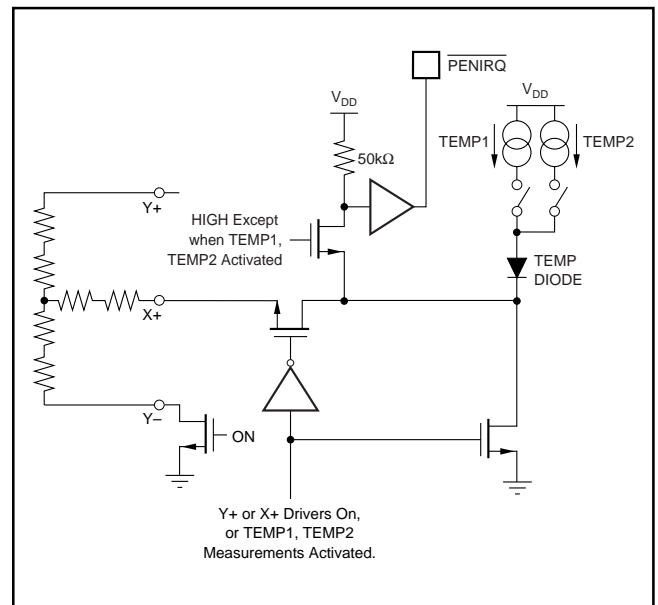

FIGURE 6. \overline{PENIRQ} Functional Block Diagram.

pulled to ground through the touch screen and $\overline{\text{PENIRQ}}$ output goes LOW due to the current path through the panel to GND, initiating an interrupt to the processor. During the measurement cycles for the X- and Y-positions, the X+ input will be disconnected from the $\overline{\text{PENIRQ}}$ pull-down transistor to eliminate any leakage current from the pull-up resistor to flow through the touch screen, thus causing no errors.

In modes where the TSC2000 needs to detect if the screen is still touched (for example, when doing a $\overline{\text{PENIRQ}}$ -initiated X, Y, and Z conversion), the TSC2000 must reset the drivers so that the 50k Ω resistor is connected again. Due to the high value of this pull-up resistor, any capacitance on the touch screen inputs will cause a long delay time, and may prevent the detection from occurring correctly. To prevent this, the TSC2000 has a circuit which allows any screen capacitance to be “precharged”, so that the pull-up resistor doesn’t have to be the only source for the charging current. The time allowed for this precharge, as well as the time needed to sense if the screen is still touched, can be set in the Configuration Control register.

This illustrates the need to use the minimum capacitor values possible on the touch screen inputs. These capacitors may be needed to reduce noise, but too large a value will increase the needed precharge and sense times, as well as panel voltage stabilization time.

DIGITAL INTERFACE

The TSC2000 communicates through a standard SPI bus. The SPI allows full-duplex, synchronous, serial communication between a host processor (the master) and peripheral devices (slaves). The SPI master generates the synchronizing clock and initiates transmissions. The SPI slave devices depend on a master to start and synchronize transmissions.

A transmission begins when initiated by a master SPI. The byte from the master SPI begins shifting in on the slave MOSI pin under the control of the master serial clock. As the byte shifts in on the MOSI pin, a byte shifts out on the MISO pin to the master shift register.

The idle state of the serial clock for the TSC2000 is LOW, which corresponds to a clock polarity setting of 0 (typical microprocessor SPI control bit CPOL = 0). The TSC2000 interface is designed so that with a clock phase bit setting of 1 (typical microprocessor SPI control bit CPHA = 1), the master begins driving its MOSI pin and the slave begins driving its MISO pin on the first serial clock edge. The $\overline{\text{SS}}$ pin should idle HIGH between transmissions. The TSC2000 will only interpret command words which are transmitted after the falling edge of $\overline{\text{SS}}$.

TSC2000 COMMUNICATION PROTOCOL

The TSC2000 is entirely controlled by registers. Reading and writing these registers is accomplished by the use of a 16-bit command, which is sent prior to the data for that register. The command is constructed as shown in Table I.

The command word begins with a $\overline{\text{R/W}}$ bit, which specifies the direction of data flow on the serial bus. The following four bits specify the page of memory this command is directed to, as shown in Table II. The next six bits specify the register address on that page of memory to which the data is directed. The last five bits are reserved for future use.

| PG3 | PG2 | PG1 | PG0 | PAGE ADDRESSED |
|-----|-----|-----|-----|----------------|
| 0 | 0 | 0 | 0 | 0 |
| 0 | 0 | 0 | 1 | 1 |
| 0 | 0 | 1 | 0 | Reserved |
| 0 | 0 | 1 | 1 | Reserved |
| 0 | 1 | 0 | 0 | Reserved |
| 0 | 1 | 0 | 1 | Reserved |
| 0 | 1 | 1 | 0 | Reserved |
| 0 | 1 | 1 | 1 | Reserved |
| 1 | 0 | 0 | 0 | Reserved |
| 1 | 0 | 0 | 1 | Reserved |
| 1 | 0 | 1 | 0 | Reserved |
| 1 | 0 | 1 | 1 | Reserved |
| 1 | 1 | 0 | 0 | Reserved |
| 1 | 1 | 0 | 1 | Reserved |
| 1 | 1 | 1 | 0 | Reserved |
| 1 | 1 | 1 | 1 | Reserved |

TABLE II. Page Addressing.

| MSB BIT 15 | BIT 14 | BIT 13 | BIT 12 | BIT 11 | BIT 10 | BIT 9 | BIT 8 | BIT 7 | BIT 6 | BIT 5 | BIT 4 | BIT 3 | BIT 2 | BIT 1 | LSB BIT 0 |
|-------------------------|--------|--------|--------|--------|--------|-------|-------|-------|-------|-------|-------|-------|-------|-------|--------------|
| $\overline{\text{R/W}}$ | PG3 | PG2 | PG1 | PG0 | ADDR5 | ADDR4 | ADDR3 | ADDR2 | ADDR1 | ADDR0 | X | X | X | X | X |

TABLE I. TSC2000 Command Word.

To read all the first page of memory, for example, the host processor must send the TSC2000 the command 8000_H—this specifies a read operation beginning at Page 0, Address 0. The processor can then start clocking data out of the TSC2000. The TSC2000 will automatically increment its address pointer to the end of the page; if the host processor continues clocking data out past the end of a page, the TSC2000 will simply send back the value FFFF_H.

Likewise, writing to Page 1 of memory would consist of the processor writing the command 0800_H, which would specify a write operation, with PG0 set to 1, and all the ADDR bits set to 0. This would result in the address pointer pointing at the first location in memory on Page 1. See the TSC2000 Memory Map section for details of register locations. Figure 7 shows an example of a complete data transaction between the host processor and the TSC2000.

TSC2000 MEMORY MAP

The TSC2000 has several 16-bit registers which allow control of the device as well as providing a location for results from the TSC2000 to be stored until read by the host microprocessor. These registers are separated into two pages of memory in the TSC2000: a Data page (Page 0) and a Control page (Page 1). The memory map is shown in Table III.

| PAGE 0: DATA REGISTERS | | PAGE 1: CONTROL REGISTERS | |
|------------------------|----------------|---------------------------|----------|
| ADDR | REGISTER | ADDR | REGISTER |
| 00 | X | 00 | ADC |
| 01 | Y | 01 | Reserved |
| 02 | Z ₁ | 02 | DACCTL |
| 03 | Z ₂ | 03 | REF |
| 04 | Reserved | 04 | RESET |
| 05 | BAT1 | 05 | CONFIG |
| 06 | BAT2 | 06 | Reserved |
| 07 | AUX1 | 07 | Reserved |
| 08 | AUX2 | 08 | Reserved |
| 09 | TEMP1 | 09 | Reserved |
| 0A | TEMP2 | 0A | Reserved |
| 0B | DAC | 0B | Reserved |
| 0C | Reserved | 0C | Reserved |
| 0D | Reserved | 0D | Reserved |
| 0E | Reserved | 0E | Reserved |
| 0F | Reserved | 0F | Reserved |
| 10 | ZERO | 10 | Reserved |
| 11 | Reserved | 11 | Reserved |
| 12 | Reserved | 12 | Reserved |
| 13 | Reserved | 13 | Reserved |
| 14 | Reserved | 14 | Reserved |
| 15 | Reserved | 15 | Reserved |
| 16 | Reserved | 16 | Reserved |
| 17 | Reserved | 17 | Reserved |
| 18 | Reserved | 18 | Reserved |
| 19 | Reserved | 19 | Reserved |
| 1A | Reserved | 1A | Reserved |
| 1B | Reserved | 1B | Reserved |
| 1C | Reserved | 1C | Reserved |
| 1D | Reserved | 1D | Reserved |
| 1E | Reserved | 1E | Reserved |
| 1F | Reserved | 1F | Reserved |

TABLE III. TSC2000 Memory Map.

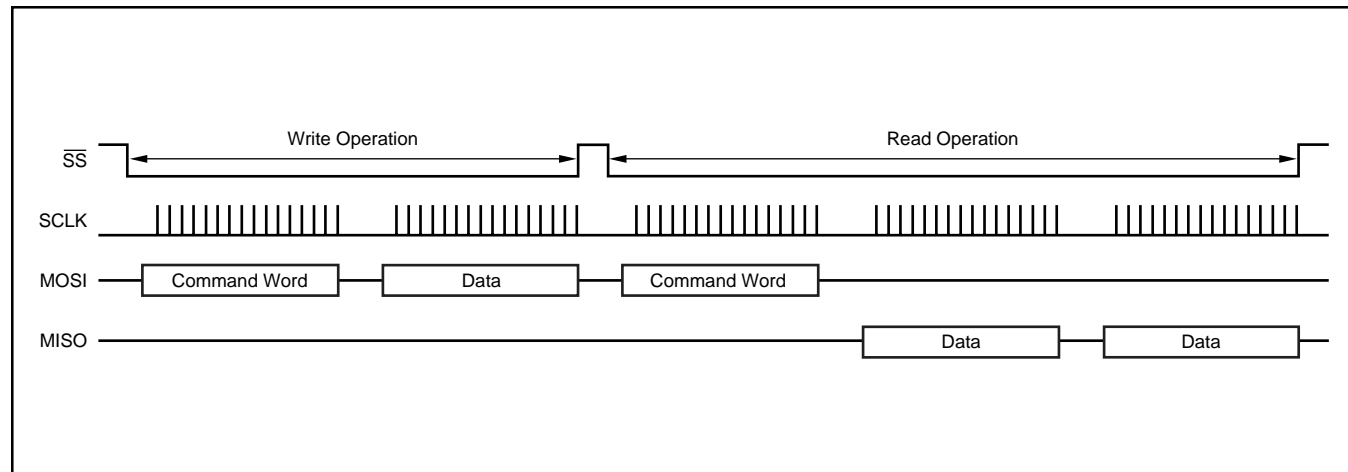

FIGURE 7. Write and Read Operation of TSC2000 Interface.

TSC2000 CONTROL REGISTERS

This section will describe each of the registers that were shown in the memory map of Table III. The registers are grouped according to the function they control. Note that in

the TSC2000, bits in control registers may refer to slightly different functions depending upon if you are reading the register or writing to it. A summary of all registers and bit locations is shown in Table IV.

| PAGE | ADDR (HEX) | REGISTER NAME | D15 | D14 | D13 | D12 | D11 | D10 | D9 | D8 | D7 | D6 | D5 | D4 | D3 | D2 | D1 | D0 | RESET VALUE (HEX) |
|------|------------|----------------|-----|-----|-----|-----|-----|-----|-----|-----|-----|-----|-----|-----|-----|-----|-----|-----|-------------------|
| 0 | 00 | X | 0 | 0 | 0 | 0 | R11 | R10 | R9 | R8 | R7 | R6 | R5 | R4 | R3 | R2 | R1 | R0 | 0000 |
| 0 | 01 | Y | 0 | 0 | 0 | 0 | R11 | R10 | R9 | R8 | R7 | R6 | R5 | R4 | R3 | R2 | R1 | R0 | 0000 |
| 0 | 02 | Z ₁ | 0 | 0 | 0 | 0 | R11 | R10 | R9 | R8 | R7 | R6 | R5 | R4 | R3 | R2 | R1 | R0 | 0000 |
| 0 | 03 | Z ₂ | 0 | 0 | 0 | 0 | R11 | R10 | R9 | R8 | R7 | R6 | R5 | R4 | R3 | R2 | R1 | R0 | 0000 |
| 0 | 04 | Reserved | 0 | 0 | 0 | 0 | 0 | 0 | 0 | 0 | 0 | 0 | 0 | 0 | 0 | 0 | 0 | 0 | 0000 |
| 0 | 05 | BAT1 | 0 | 0 | 0 | 0 | R11 | R10 | R9 | R8 | R7 | R6 | R5 | R4 | R3 | R2 | R1 | R0 | 0000 |
| 0 | 06 | BAT2 | 0 | 0 | 0 | 0 | R11 | R10 | R9 | R8 | R7 | R6 | R5 | R4 | R3 | R2 | R1 | R0 | 0000 |
| 0 | 07 | AUX1 | 0 | 0 | 0 | 0 | R11 | R10 | R9 | R8 | R7 | R6 | R5 | R4 | R3 | R2 | R1 | R0 | 0000 |
| 0 | 08 | AUX2 | 0 | 0 | 0 | 0 | R11 | R10 | R9 | R8 | R7 | R6 | R5 | R4 | R3 | R2 | R1 | R0 | 0000 |
| 0 | 09 | TEMP1 | 0 | 0 | 0 | 0 | R11 | R10 | R9 | R8 | R7 | R6 | R5 | R4 | R3 | R2 | R1 | R0 | 0000 |
| 0 | 0A | TEMP2 | 0 | 0 | 0 | 0 | R11 | R10 | R9 | R8 | R7 | R6 | R5 | R4 | R3 | R2 | R1 | R0 | 0000 |
| 0 | 0B | DAC | X | X | X | X | X | X | X | X | D7 | D6 | D5 | D4 | D3 | D2 | D1 | D0 | 007F |
| 0 | 0C | Reserved | 1 | 1 | 1 | 1 | 1 | 1 | 1 | 1 | 1 | 1 | 1 | 1 | 1 | 1 | 1 | 1 | FFFF |
| 0 | 0D | Reserved | 1 | 1 | 1 | 1 | 1 | 1 | 1 | 1 | 1 | 1 | 1 | 1 | 1 | 1 | 1 | 1 | FFFF |
| 0 | 0E | Reserved | 1 | 1 | 1 | 1 | 1 | 1 | 1 | 1 | 1 | 1 | 1 | 1 | 1 | 1 | 1 | 1 | FFFF |
| 0 | 0F | Reserved | 1 | 1 | 1 | 1 | 1 | 1 | 1 | 1 | 1 | 1 | 1 | 1 | 1 | 1 | 1 | 1 | FFFF |
| 0 | 10 | ZERO | 0 | 0 | 0 | 0 | 0 | 0 | 0 | 0 | 0 | 0 | 0 | 0 | 0 | 0 | 0 | 0 | 0000 |
| 0 | 11 | Reserved | 1 | 1 | 1 | 1 | 1 | 1 | 1 | 1 | 1 | 1 | 1 | 1 | 1 | 1 | 1 | 1 | FFFF |
| 0 | 12 | Reserved | 1 | 1 | 1 | 1 | 1 | 1 | 1 | 1 | 1 | 1 | 1 | 1 | 1 | 1 | 1 | 1 | FFFF |
| 0 | 13 | Reserved | 1 | 1 | 1 | 1 | 1 | 1 | 1 | 1 | 1 | 1 | 1 | 1 | 1 | 1 | 1 | 1 | FFFF |
| 0 | 14 | Reserved | 1 | 1 | 1 | 1 | 1 | 1 | 1 | 1 | 1 | 1 | 1 | 1 | 1 | 1 | 1 | 1 | FFFF |
| 0 | 15 | Reserved | 1 | 1 | 1 | 1 | 1 | 1 | 1 | 1 | 1 | 1 | 1 | 1 | 1 | 1 | 1 | 1 | FFFF |
| 0 | 16 | Reserved | 1 | 1 | 1 | 1 | 1 | 1 | 1 | 1 | 1 | 1 | 1 | 1 | 1 | 1 | 1 | 1 | FFFF |
| 0 | 17 | Reserved | 1 | 1 | 1 | 1 | 1 | 1 | 1 | 1 | 1 | 1 | 1 | 1 | 1 | 1 | 1 | 1 | FFFF |
| 0 | 18 | Reserved | 1 | 1 | 1 | 1 | 1 | 1 | 1 | 1 | 1 | 1 | 1 | 1 | 1 | 1 | 1 | 1 | FFFF |
| 0 | 19 | Reserved | 1 | 1 | 1 | 1 | 1 | 1 | 1 | 1 | 1 | 1 | 1 | 1 | 1 | 1 | 1 | 1 | FFFF |
| 0 | 1A | Reserved | 1 | 1 | 1 | 1 | 1 | 1 | 1 | 1 | 1 | 1 | 1 | 1 | 1 | 1 | 1 | 1 | FFFF |
| 0 | 1B | Reserved | 1 | 1 | 1 | 1 | 1 | 1 | 1 | 1 | 1 | 1 | 1 | 1 | 1 | 1 | 1 | 1 | FFFF |
| 0 | 1C | Reserved | 1 | 1 | 1 | 1 | 1 | 1 | 1 | 1 | 1 | 1 | 1 | 1 | 1 | 1 | 1 | 1 | FFFF |
| 0 | 1D | Reserved | 1 | 1 | 1 | 1 | 1 | 1 | 1 | 1 | 1 | 1 | 1 | 1 | 1 | 1 | 1 | 1 | FFFF |
| 0 | 1E | Reserved | 1 | 1 | 1 | 1 | 1 | 1 | 1 | 1 | 1 | 1 | 1 | 1 | 1 | 1 | 1 | 1 | FFFF |
| 0 | 1F | Reserved | 1 | 1 | 1 | 1 | 1 | 1 | 1 | 1 | 1 | 1 | 1 | 1 | 1 | 1 | 1 | 1 | FFFF |
| 1 | 00 | ADC | PSM | STS | AD3 | AD2 | AD1 | AD0 | RS1 | RS0 | AV1 | AV0 | CL1 | CL0 | PV2 | PV1 | PV0 | x | 4000 |
| 1 | 01 | Reserved | 0 | 1 | 0 | 0 | 0 | 0 | 0 | 0 | 0 | 0 | 0 | 0 | 0 | 0 | 0 | 0 | 4000 |
| 1 | 02 | DACCTL | DPD | 0 | 0 | 0 | 0 | 0 | 0 | 0 | 0 | 0 | 0 | 0 | 0 | 0 | 0 | 0 | 8000 |
| 1 | 03 | REF | X | X | X | X | X | X | X | X | X | X | X | INT | DL1 | DL0 | PND | RFV | 0002 |
| 1 | 04 | RESET | 1 | 0 | 1 | 1 | 1 | 0 | 1 | 1 | X | X | X | X | X | X | X | X | FFFF |
| 1 | 05 | CONFIG | 1 | 1 | 1 | 1 | 1 | 1 | 1 | 1 | 1 | 1 | PR2 | PR1 | PR0 | SN2 | SN1 | SN0 | FFC0 |
| 1 | 06 | Reserved | 1 | 1 | 1 | 1 | 1 | 1 | 1 | 1 | 1 | 1 | 1 | 1 | 1 | 1 | 1 | 1 | FFFF |
| 1 | 07 | Reserved | 1 | 1 | 1 | 1 | 1 | 1 | 1 | 1 | 1 | 1 | 1 | 1 | 1 | 1 | 1 | 1 | FFFF |
| 1 | 08 | Reserved | 1 | 1 | 1 | 1 | 1 | 1 | 1 | 1 | 1 | 1 | 1 | 1 | 1 | 1 | 1 | 1 | FFFF |
| 1 | 09 | Reserved | 1 | 1 | 1 | 1 | 1 | 1 | 1 | 1 | 1 | 1 | 1 | 1 | 1 | 1 | 1 | 1 | FFFF |
| 1 | 0A | Reserved | 1 | 1 | 1 | 1 | 1 | 1 | 1 | 1 | 1 | 1 | 1 | 1 | 1 | 1 | 1 | 1 | FFFF |
| 1 | 0B | Reserved | 1 | 1 | 1 | 1 | 1 | 1 | 1 | 1 | 1 | 1 | 1 | 1 | 1 | 1 | 1 | 1 | FFFF |
| 1 | 0C | Reserved | 1 | 1 | 1 | 1 | 1 | 1 | 1 | 1 | 1 | 1 | 1 | 1 | 1 | 1 | 1 | 1 | FFFF |
| 1 | 0D | Reserved | 1 | 1 | 1 | 1 | 1 | 1 | 1 | 1 | 1 | 1 | 1 | 1 | 1 | 1 | 1 | 1 | FFFF |
| 1 | 0E | Reserved | 1 | 1 | 1 | 1 | 1 | 1 | 1 | 1 | 1 | 1 | 1 | 1 | 1 | 1 | 1 | 1 | FFFF |
| 1 | 0F | Reserved | 1 | 1 | 1 | 1 | 1 | 1 | 1 | 1 | 1 | 1 | 1 | 1 | 1 | 1 | 1 | 1 | FFFF |
| 1 | 10 | Reserved | 0 | 0 | 0 | 0 | 0 | 0 | 0 | 0 | 0 | 0 | 0 | 0 | 0 | 0 | 0 | 0 | 0000 |
| 1 | 11 | Reserved | 1 | 1 | 1 | 1 | 1 | 1 | 1 | 1 | 1 | 1 | 1 | 1 | 1 | 1 | 1 | 1 | FFFF |
| 1 | 12 | Reserved | 1 | 1 | 1 | 1 | 1 | 1 | 1 | 1 | 1 | 1 | 1 | 1 | 1 | 1 | 1 | 1 | FFFF |
| 1 | 13 | Reserved | 1 | 1 | 1 | 1 | 1 | 1 | 1 | 1 | 1 | 1 | 1 | 1 | 1 | 1 | 1 | 1 | FFFF |
| 1 | 14 | Reserved | 1 | 1 | 1 | 1 | 1 | 1 | 1 | 1 | 1 | 1 | 1 | 1 | 1 | 1 | 1 | 1 | FFFF |
| 1 | 15 | Reserved | 1 | 1 | 1 | 1 | 1 | 1 | 1 | 1 | 1 | 1 | 1 | 1 | 1 | 1 | 1 | 1 | FFFF |
| 1 | 16 | Reserved | 1 | 1 | 1 | 1 | 1 | 1 | 1 | 1 | 1 | 1 | 1 | 1 | 1 | 1 | 1 | 1 | FFFF |
| 1 | 17 | Reserved | 1 | 1 | 1 | 1 | 1 | 1 | 1 | 1 | 1 | 1 | 1 | 1 | 1 | 1 | 1 | 1 | FFFF |
| 1 | 18 | Reserved | 1 | 1 | 1 | 1 | 1 | 1 | 1 | 1 | 1 | 1 | 1 | 1 | 1 | 1 | 1 | 1 | FFFF |
| 1 | 19 | Reserved | 1 | 1 | 1 | 1 | 1 | 1 | 1 | 1 | 1 | 1 | 1 | 1 | 1 | 1 | 1 | 1 | FFFF |
| 1 | 1A | Reserved | 1 | 1 | 1 | 1 | 1 | 1 | 1 | 1 | 1 | 1 | 1 | 1 | 1 | 1 | 1 | 1 | FFFF |
| 1 | 1B | Reserved | 1 | 1 | 1 | 1 | 1 | 1 | 1 | 1 | 1 | 1 | 1 | 1 | 1 | 1 | 1 | 1 | FFFF |
| 1 | 1C | Reserved | 1 | 1 | 1 | 1 | 1 | 1 | 1 | 1 | 1 | 1 | 1 | 1 | 1 | 1 | 1 | 1 | FFFF |
| 1 | 1D | Reserved | 1 | 1 | 1 | 1 | 1 | 1 | 1 | 1 | 1 | 1 | 1 | 1 | 1 | 1 | 1 | 1 | FFFF |
| 1 | 1E | Reserved | 1 | 1 | 1 | 1 | 1 | 1 | 1 | 1 | 1 | 1 | 1 | 1 | 1 | 1 | 1 | 1 | FFFF |
| 1 | 1F | Reserved | 1 | 1 | 1 | 1 | 1 | 1 | 1 | 1 | 1 | 1 | 1 | 1 | 1 | 1 | 1 | 1 | FFFF |

NOTE: X = Don't Care.

TABLE IV. Register Summary for TSC2000.

TSC2000 A/D CONVERTER CONTROL REGISTER (PAGE 1, ADDRESS 00_H)

The A/D converter in the TSC2000 is shared between all the different functions. A control register determines which input is selected, as well as other options. The result of the conversion is placed in one of the result registers in Page 0 of memory, depending upon the function selected.

The A/D Converter Control Register controls several aspects of the A/D converter. The register is formatted as shown in Table VI.

Bit 15: PSM—Pen Status/Control Mode. Reading this bit allows the host to determine if the screen is touched. Writing to this bit determines the mode used to read coordinates: host controlled, or under control of the TSC2000 responding to a screen touch. When reading, the PENSTS bit indicates if the pen is down or not. When writing to this register, this bit determines if the TSC2000 controls the reading of coordinates, or if the coordinate conversions are host-controlled. The default state is host-controlled conversions (0).

| PSM | | |
|------------|-------|-----------------------------------|
| READ/WRITE | VALUE | DESCRIPTION |
| Read | 0 | No Screen Touch Detected |
| Read | 1 | Screen Touch Detected |
| Write | 0 | Conversions Controlled by Host |
| Write | 1 | Conversions Controlled by TSC2000 |

TABLE V. PSM Bit Operation.

Bit 14: STS—A/D Converter Status. When reading this bit indicates if the converter is busy, or if conversions are complete and data is available. Writing a 0 to this bit will cause touch screen scans to continue until either the pen is

lifted or the process is stopped. Continuous scans or conversions can be stopped by writing a 1 to this bit. This will immediately halt a conversion (even if the pen is still down) and cause the A/D converter to power down. The default state is continuous conversions, but if this bit is read after a reset or power-up, it will read 1.

| STS | | |
|------------|-------|---|
| READ/WRITE | VALUE | DESCRIPTION |
| Read | 0 | Converter is Busy |
| Read | 1 | Conversions are Complete, Data is Available |
| Write | 0 | Normal Operation |
| Write | 1 | Stop Conversion and Power Down |

TABLE VII. STS Bit Operation.

Bits [13:10]: AD3–AD0—A/D Converter Function Select Bits. These bits control which input is to be converted, and what mode the converter is placed in. These bits are the same whether reading or writing. A complete listing of how these bits are used is shown in Table VIII.

Bits[9:8]: RS1, RS0—Resolution Control. The A/D converter resolution is specified with these bits. A description of these bits is shown in Table IX. These bits are the same whether reading or writing.

| RS1 | RS0 | FUNCTION |
|-----|-----|--|
| 0 | 0 | 12-Bit Resolution. Power up and reset default. |
| 0 | 1 | 8-Bit Resolution |
| 1 | 0 | 10-Bit Resolution |
| 1 | 1 | 12-Bit Resolution |

TABLE IX. A/D Converter Resolution Control.

| MSB BIT 15 | BIT 14 | BIT 13 | BIT 12 | BIT 11 | BIT 10 | BIT 9 | BIT 8 | BIT 7 | BIT 6 | BIT 5 | BIT 4 | BIT 3 | BIT 2 | BIT 1 | LSB BIT 0 |
|---------------|--------|--------|--------|--------|--------|-------|-------|-------|-------|-------|-------|-------|-------|-------|--------------|
| PSM | STS | AD3 | AD2 | AD1 | AD0 | RS1 | RS0 | AV1 | AV0 | CL1 | CL0 | PV2 | PV1 | PV0 | X |

TABLE VI. A/D Converter Control Register.

| A/D3 | A/D2 | A/D1 | A/D0 | FUNCTION |
|------|------|------|------|--|
| 0 | 0 | 0 | 0 | Invalid. No registers will be updated. This is the default state after a reset. |
| 0 | 0 | 0 | 1 | Touch screen scan function: X and Y coordinates converted and the results returned to X and Y data registers. Scan continues until either the pen is lifted or a stop bit is sent. |
| 0 | 0 | 1 | 0 | Touch screen scan function: X, Y, Z ₁ , and Z ₂ coordinates converted and the results returned to X, Y, Z ₁ , and Z ₂ data registers. Scan continues until either the pen is lifted or a stop bit is sent. |
| 0 | 0 | 1 | 1 | Touch screen scan function: X coordinate converted and the results returned to X data register. |
| 0 | 1 | 0 | 0 | Touch screen scan function: Y coordinate converted and the results returned to Y data register. |
| 0 | 1 | 0 | 1 | Touch screen scan function: Z ₁ and Z ₂ coordinates converted and the results returned to Z ₁ and Z ₂ data registers. |
| 0 | 1 | 1 | 0 | Battery Input 1 converted and the results returned to the BAT1 data register. |
| 0 | 1 | 1 | 1 | Battery Input 2 converted and the results returned to the BAT2 data register. |
| 1 | 0 | 0 | 0 | Auxiliary Input 1 converted and the results returned to the AUX1 data register. |
| 1 | 0 | 0 | 1 | Auxiliary Input 2 converted and the results returned to the AUX2 data register. |
| 1 | 0 | 1 | 0 | A temperature measurement is made and the results returned to the temperature measurement 1 data register. |
| 1 | 0 | 1 | 1 | Port scan function: Battery Input 1, Battery Input 2, Auxiliary Input 1, and a Auxiliary Input measurements are made and the results returned to the appropriate data registers. |
| 1 | 1 | 0 | 0 | A differential temperature measurement is made and the results returned to the temperature measurement 2 data register. |
| 1 | 1 | 0 | 1 | Turn on X+, X- drivers. |
| 1 | 1 | 1 | 0 | Turn on Y+, Y- drivers. |
| 1 | 1 | 1 | 1 | Turn on Y+, X- drivers. |

TABLE VIII. A/D Converter Function Select.

Bits[7:6]: AV1, AV0 = Converter Averaging Control. These two bits allow you to specify the number of averages the converter will perform, as shown in Table X. Note that when averaging is used, the STS bit and the \overline{DAV} output will indicate that the converter is busy until all conversions necessary for the averaging are complete. The default state for these bits is 00, selecting no averaging. These bits are the same whether reading or writing.

| AV1 | AV0 | FUNCTION |
|-----|-----|------------------|
| 0 | 0 | None |
| 0 | 1 | 4 Data Averages |
| 1 | 0 | 8 Data Averages |
| 1 | 1 | 16 Data Averages |

TABLE X. A/D Conversion Averaging Control.

Bits[5:4]: CL1, CL0 = Conversion Clock Control. These two bits specify the internal clock rate which the A/D converter uses when performing a single conversion, as shown in Table XI. These bits are the same whether reading or writing.

| CL1 | CL0 | FUNCTION |
|-----|-----|---|
| 0 | 0 | 8MHz Internal Clock Rate—8-Bit Resolution Only |
| 0 | 1 | 4MHz Internal Clock Rate—10-Bit Resolution Only |
| 1 | 0 | 2MHz Internal Clock Rate. |
| 1 | 1 | 1MHz Internal Clock Rate. |

TABLE XI. A/D Converter Clock Control.

Bits [3:1]: PV2 – PV0 = Panel Voltage Stabilization Time control. These bits allow you to specify a delay time from the time a pen touch is detected to the time a conversion is started. This allows you to select the appropriate settling time for the touch panel used. Table XII shows the settings of these bits. The default state is 000, indicating a 0ms stabilization time. These bits are the same whether reading or writing.

Bit 0: This bit is not used, and is a “don’t care” when writing. It will always read as a zero.

| PV2 | PV1 | PV0 | FUNCTION |
|-----|-----|-----|--------------------------------|
| 0 | 0 | 0 | 0 μ s Stabilization Time |
| 0 | 0 | 1 | 100 μ s Stabilization Time |
| 0 | 1 | 0 | 500 μ s Stabilization Time |
| 0 | 1 | 1 | 1ms Stabilization Time |
| 1 | 0 | 0 | 5ms Stabilization Time |
| 1 | 0 | 1 | 10ms Stabilization Time |
| 1 | 1 | 0 | 50ms Stabilization Time |
| 1 | 1 | 1 | 100ms Stabilization Time |

TABLE XII. Panel Voltage Stabilization Time Control.

| MSB BIT 15 | BIT 14 | BIT 13 | BIT 12 | BIT 11 | BIT 10 | BIT 9 | BIT 8 | BIT 7 | BIT 6 | BIT 5 | BIT 4 | BIT 3 | BIT 2 | BIT 1 | LSB BIT 0 |
|---------------|--------|--------|--------|--------|--------|-------|-------|-------|-------|-------|-------|-------|-------|-------|--------------|
| DPD | X | X | X | X | X | X | X | X | X | X | X | X | X | X | X |

TABLE XIII. D/A Converter Control Register.

| MSB BIT 15 | BIT 14 | BIT 13 | BIT 12 | BIT 11 | BIT 10 | BIT 9 | BIT 8 | BIT 7 | BIT 6 | BIT 5 | BIT 4 | BIT 3 | BIT 2 | BIT 1 | LSB BIT 0 |
|---------------|--------|--------|--------|--------|--------|-------|-------|-------|-------|-------|-------|-------|-------|-------|--------------|
| X | X | X | X | X | X | X | X | X | X | X | INT | DL1 | DL0 | PDN | RFV |

TABLE XV. Reference Register.

D/A CONVERTER CONTROL REGISTER (PAGE 1, ADDRESS 02_H)

The single bit in this register controls the power down control of the on-board D/A converter. This register is formatted as shown in Table XIII.

Bit 15: DPD = D/A Converter Power Down. This bit controls whether the D/A converter is powered up and operational, or powered down. If the D/A converter is powered down, the A_{OUT} pin will neither sink nor source current.

| DPD | |
|-------|--|
| VALUE | DESCRIPTION |
| 0 | D/A Converter is Powered and Operational |
| 1 | D/A Converter is Powered Down |

TABLE XIV. DPD Bit Operation.

REFERENCE REGISTER (PAGE 1, ADDRESS 03_H)

The TSC2000 has a register to control the operation of the internal reference. This register is formatted as shown in Table XV.

Bit 4: \overline{INT} = Internal Reference Mode. If this bit is written to a 1, the TSC2000 will use its internal reference; if this bit is a zero, the part will assume an external reference is being supplied. The default state for this bit is to select an external reference (0). This bit is the same whether reading or writing.

| \overline{INT} | |
|------------------|-----------------------------|
| VALUE | DESCRIPTION |
| 0 | External Reference Selected |
| 1 | Internal Reference Selected |

TABLE XVI. \overline{INT} Bit Operation.

Bits [3:2]: DL1, DL0 = Reference Power-Up Delay. When the internal reference is powered up, a finite amount of time is required for the reference to settle. If measurements are made before the reference has settled, these measurements will be in error. These bits allow for a delay time for measurements to be made after the reference powers up, thereby assuring that the reference has settled. Longer delays will be necessary depending upon the capacitance present at the REF pin (see Typical Characteristics).

See Table XVII for the delays. The default state for these bits is 00, selecting a 0ms delay. These bits are the same whether reading or writing.

| DL1 | DL0 | DELAY TIME |
|-----|-----|--------------|
| 0 | 0 | 0 μ s |
| 0 | 1 | 100 μ s |
| 1 | 0 | 500 μ s |
| 1 | 1 | 1000 μ s |

TABLE XVII. Reference Power-Up Delay Settings.

Bit 1: PDN = Reference Power Down. If a 1 is written to this bit, the internal reference will be powered down between conversions. If this bit is a zero, the internal reference will be powered at all times. The default state is to power down the internal reference, so this bit will be a 1. This bit is the same whether reading or writing.

| PDN | |
|-------|--|
| VALUE | DESCRIPTION |
| 0 | Internal Reference is Powered at All Times |
| 1 | Internal Reference is Powered Down Between Conversions |

TABLE XVIII. PDN Bit Operation.

Note that the PDN bit, in concert with the $\overline{\text{INT}}$ bit, creates a few possibilities for reference behavior. These are detailed in Table XIX.

| INT | PDN | REFERENCE BEHAVIOR |
|-----|-----|---|
| 0 | 0 | External Reference Used, Internal Reference Powered Down |
| 0 | 1 | External Reference Used, Internal Reference Powered Down |
| 1 | 0 | Internal Reference Used, Always Powered Up |
| 1 | 1 | Internal Reference Used, Will Power Up During Conversions and Then Power Down |

TABLE XIX. Reference Behavior Possibilities.

Bit 0: RFV = Reference Voltage control. This bit selects the internal reference voltage, either 1.25V or 2.5V. The default value is 1.25V. This bit is the same whether reading or writing.

| RFV | |
|-------|-------------------------|
| VALUE | DESCRIPTION |
| 0 | 1.25V Reference Voltage |
| 1 | 2.5V Reference Voltage |

TABLE XX. RFV Bit Operation.

| MSB BIT 15 | BIT 14 | BIT 13 | BIT 12 | BIT 11 | BIT 10 | BIT 9 | BIT 8 | BIT 7 | BIT 6 | BIT 5 | BIT 4 | BIT 3 | BIT 2 | BIT 1 | LSB BIT 0 |
|---------------|--------|--------|--------|--------|--------|-------|-------|-------|-------|-------|-------|-------|-------|-------|--------------|
| X | X | X | X | X | X | X | X | X | X | PRE2 | PRE1 | PRE0 | SNS2 | SNS1 | SNS0 |

TABLE XXI. Configuration Control Register.

TSC2000 CONFIGURATION CONTROL REGISTER (PAGE 1, ADDRESS 05_H)

This control register controls the configuration of the precharge and sense times for the touch detect circuit. The register is formatted as shown in Table XXI.

Bits [5:3]: PRE[2:0] = Precharge Time Selection Bits. These bits set the amount of time allowed for precharging any pin capacitance on the touch screen prior to sensing if a screen touch is happening.

| PRE[2:0] | | | |
|----------|------|------|-------------|
| PRE2 | PRE1 | PRE0 | TIME |
| 0 | 0 | 0 | 20 μ s |
| 0 | 0 | 1 | 84 μ s |
| 0 | 1 | 0 | 276 μ s |
| 0 | 1 | 1 | 340 μ s |
| 1 | 0 | 0 | 1.044ms |
| 1 | 0 | 1 | 1.108ms |
| 1 | 1 | 0 | 1.300ms |
| 1 | 1 | 1 | 1.364ms |

TABLE XXII. Precharge Times.

Bits [2:0]: SNS[2:0] = Sense Time Selection Bits. These bits set the amount of time the TSC2000 will wait to sense a screen touch between coordinate axis conversions in PENIRQ-controlled mode.

| SNS[2:0] | | | |
|----------|------|------|-------------|
| SNS2 | SNS1 | SNS0 | TIME |
| 0 | 0 | 0 | 32 μ s |
| 0 | 0 | 1 | 96 μ s |
| 0 | 1 | 0 | 544 μ s |
| 0 | 1 | 1 | 608 μ s |
| 1 | 0 | 0 | 2.080ms |
| 1 | 0 | 1 | 2.144ms |
| 1 | 1 | 0 | 2.592ms |
| 1 | 1 | 1 | 2.656ms |

TABLE XXIII. Sense Times.

RESET REGISTER (PAGE 1, ADDRESS 04_H)

The TSC2000 has a special register, the RESET register, which allows a software reset of the device. Writing the code BBXX_H, as shown in Table XXIV, to this register will cause the TSC2000 to reset all its registers to their default, power-up values.

Writing any other values to this register will do nothing. Reading this register or any reserved register will result in reading back all 1's, or FFFF_H.

TSC2000 DATA REGISTERS

The data registers of the TSC2000 hold data results from conversions or keypad scans, or the value of the D/A converter output current. All of these registers default to 0000_H upon reset, except the D/A converter register, which is set to 0080_H, representing the midscale output of the D/A converter.

X, Y, Z₁, Z₂, BAT1, BAT2, AUX1, AUX2, TEMP1, AND TEMP2 REGISTERS

The results of all A/D conversions are placed in the appropriate data register, see Tables III and VIII. The data format of the result word, R, of these registers is right-justified, as shown in Table XXV.

D/A CONVERTER DATA REGISTER (PAGE 0, ADDRESS 0B_H)

The data to be written to the D/A converter is written into the D/A converter data register, which is formatted as shown in Table XXVI.

ZERO REGISTER (PAGE 0, ADDRESS 10_H)

This is a reserved data register, but instead of reading all 1's (FFFF_H), when read will return all 0's (0000_H).

OPERATION—TOUCH SCREEN MEASUREMENTS

As noted previously in the discussion of the A/D converter, several operating modes can be used, which allow great flexibility for the host processor. These different modes will now be examined.

Conversion Controlled by TSC2000 Initiated at Touch Detect

In this mode, the TSC2000 will detect when the touch panel is touched and cause the $\overline{\text{PENIRQ}}$ line to go LOW. At the same time, the TSC2000 will start up its internal clock. It will then turn on the Y-drivers, and after a programmed Panel Voltage Stabilization time, power up the A/D converter and convert the Y-coordinate. If averaging is selected, several conversions may take place; when data averaging is complete, the Y-coordinate result will be stored in the Y-register.

If the screen is still touched at this time, the X-drivers will be enabled, and the process will repeat, but instead measuring the X-coordinate and storing the result in the X-register.

If only X- and Y-coordinates are to be measured, then the conversion process is complete. See Figure 8 for a flowchart for this process. The time it takes to go through this process depends upon the selected resolution, internal conversion clock rate, averaging selected, panel voltage stabilization time, and precharge and sense times.

| MSB BIT 15 | BIT 14 | BIT 13 | BIT 12 | BIT 11 | BIT 10 | BIT 9 | BIT 8 | BIT 7 | BIT 6 | BIT 5 | BIT 4 | BIT 3 | BIT 2 | BIT 1 | LSB BIT 0 |
|---------------|--------|--------|--------|--------|--------|-------|-------|-------|-------|-------|-------|-------|-------|-------|--------------|
| 1 | 0 | 1 | 1 | 1 | 0 | 1 | 1 | X | X | X | X | X | X | X | X |

TABLE XXIV. Reset Register.

| MSB BIT 15 | BIT 14 | BIT 13 | BIT 12 | BIT 11 | BIT 10 | BIT 9 | BIT 8 | BIT 7 | BIT 6 | BIT 5 | BIT 4 | BIT 3 | BIT 2 | BIT 1 | LSB BIT 0 |
|---------------|--------|--------|--------|------------|--------|-------|-------|-------|-------|-------|-------|-------|-------|-------|--------------|
| 0 | 0 | 0 | 0 | R11 MSB | R10 | R9 | R8 | R7 | R6 | R5 | R4 | R3 | R2 | R1 | R0 LSB |

TABLE XXV. Result Data Format.

| MSB BIT 15 | BIT 14 | BIT 13 | BIT 12 | BIT 11 | BIT 10 | BIT 9 | BIT 8 | BIT 7 | BIT 6 | BIT 5 | BIT 4 | BIT 3 | BIT 2 | BIT 1 | LSB BIT 0 |
|---------------|--------|--------|--------|--------|--------|-------|-------|-------|-------|-------|-------|-------|-------|-------|--------------|
| X | X | X | X | X | X | X | X | D7 | D6 | D5 | D4 | D3 | D2 | D1 | D0 |

TABLE XXVI. D/A Converter Register.

The time needed to get a complete X/Y-coordinate reading can be calculated by:

(3)

$$t_{\text{COORDINATE}} = 2.5\mu\text{s} + 2(t_{\text{PVS}} + t_{\text{PRE}} + t_{\text{SNS}}) + 2N_{\text{AVG}} \left(N_{\text{BITS}} \cdot \frac{1}{f_{\text{CONV}}} + 4.4\mu\text{s} \right)$$

where,

$t_{\text{COORDINATE}}$ = time to complete X/Y-coordinate reading

t_{PVS} = Panel Voltage Stabilization time, see Table XII

t_{PRE} = precharge time, see Table XXII

t_{SNS} = sense time, see Table XXIII

N_{AVG} = number of averages, see Table X; for no averaging, $N_{\text{AVG}} = 1$

N_{BITS} = number of bits of resolution, see Table IX

f_{CONV} = A/D converter clock frequency, see Table XI

If the pressure of the touch is also to be measured, the process will continue in the same way, but measuring the Z_1 and Z_2 values, and placing them in the Z_1 and Z_2 registers, see Figure 9. As before, this process time depends upon the settings described above. The time for a complete X, Y, Z_1 , and Z_2 coordinate reading is given by:

(4)

$$t_{\text{COORDINATE}} = 4.75\mu\text{s} + 3(t_{\text{PVS}} + t_{\text{PRE}} + t_{\text{SNS}}) + 4N_{\text{AVG}} \left(N_{\text{BITS}} \cdot \frac{1}{f_{\text{CONV}}} + 4.4\mu\text{s} \right)$$

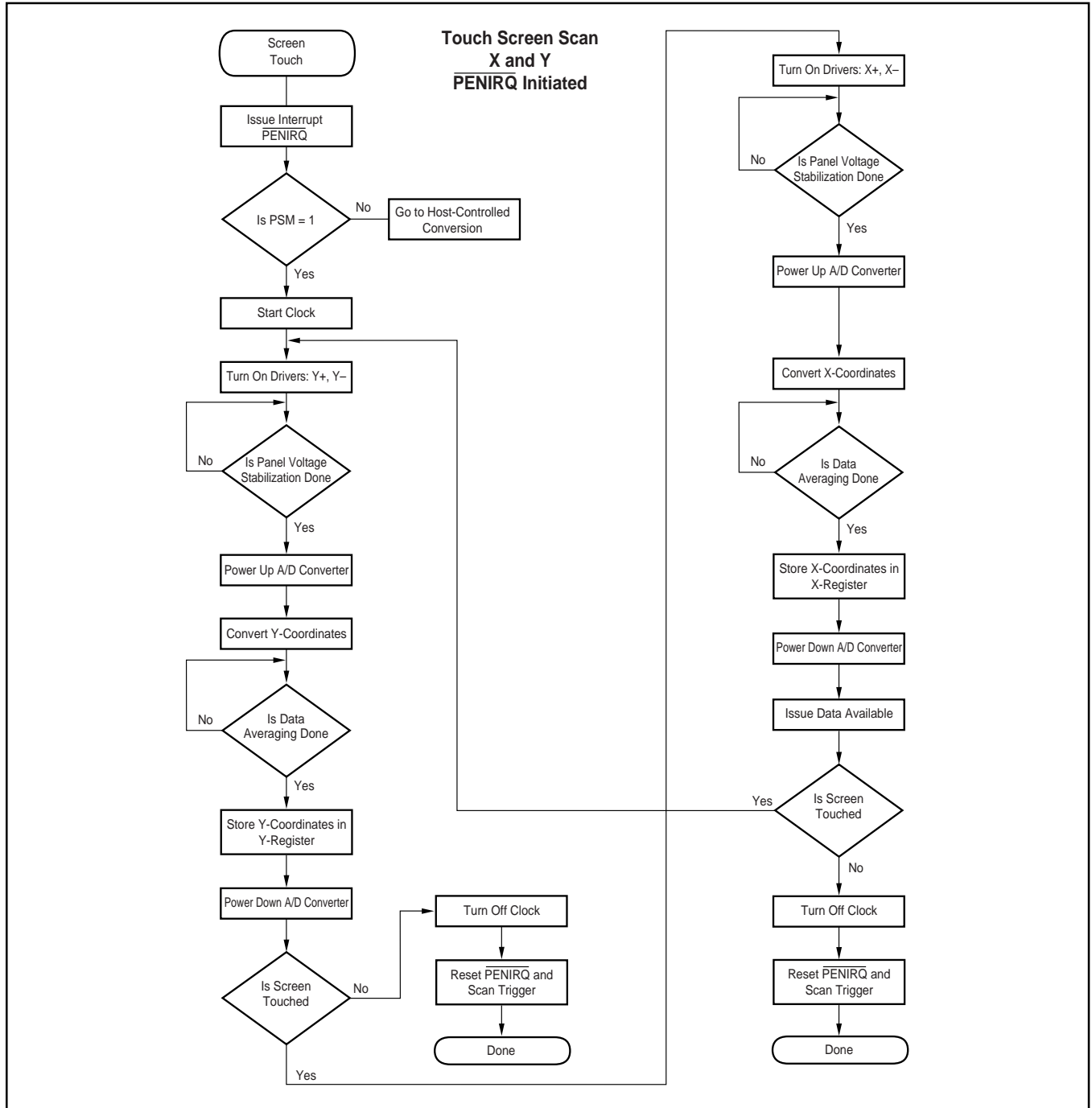

FIGURE 8. X- and Y-Coordinate Touch Screen Scan, Initiated by Touch.

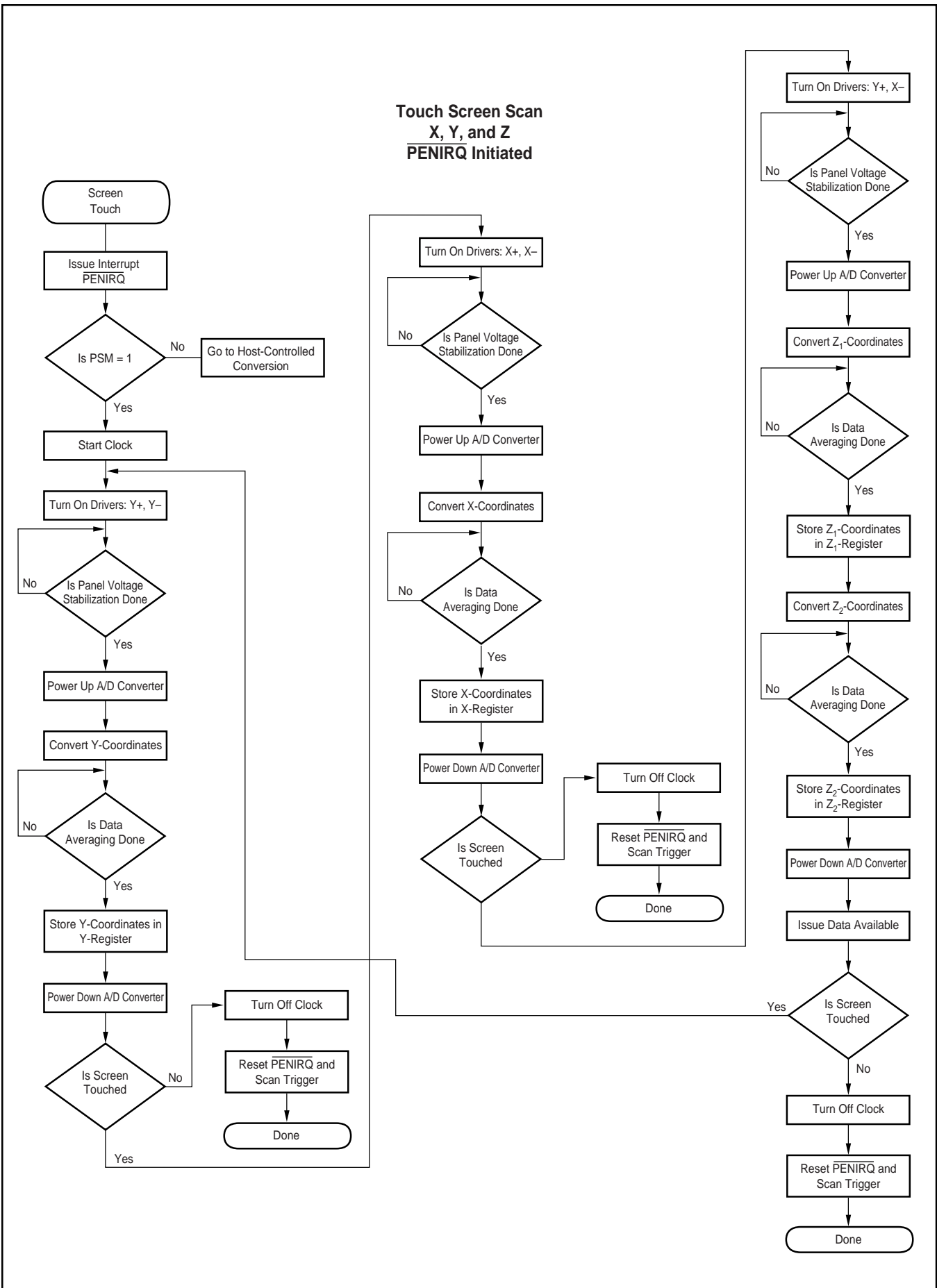

FIGURE 9. X-, Y-, and Z-Coordinate Touch Screen Scan, Initiated by Touch.

Conversion Controlled by TSC2000 Initiated By Host Responding to $\overline{\text{PENIRQ}}$

In this mode, the TSC2000 will detect when the touch panel is touched and cause the $\overline{\text{PENIRQ}}$ line to go LOW. The host will recognize the interrupt request, and then write to the A/D Converter Control register to select one of the touch screen

scan functions. The conversion process then proceeds as described above, and as outlined in Figures 10 through 14.

The main difference between this mode and the previous mode is that the host, not the TSC2000, decides when the touch screen scan begins.

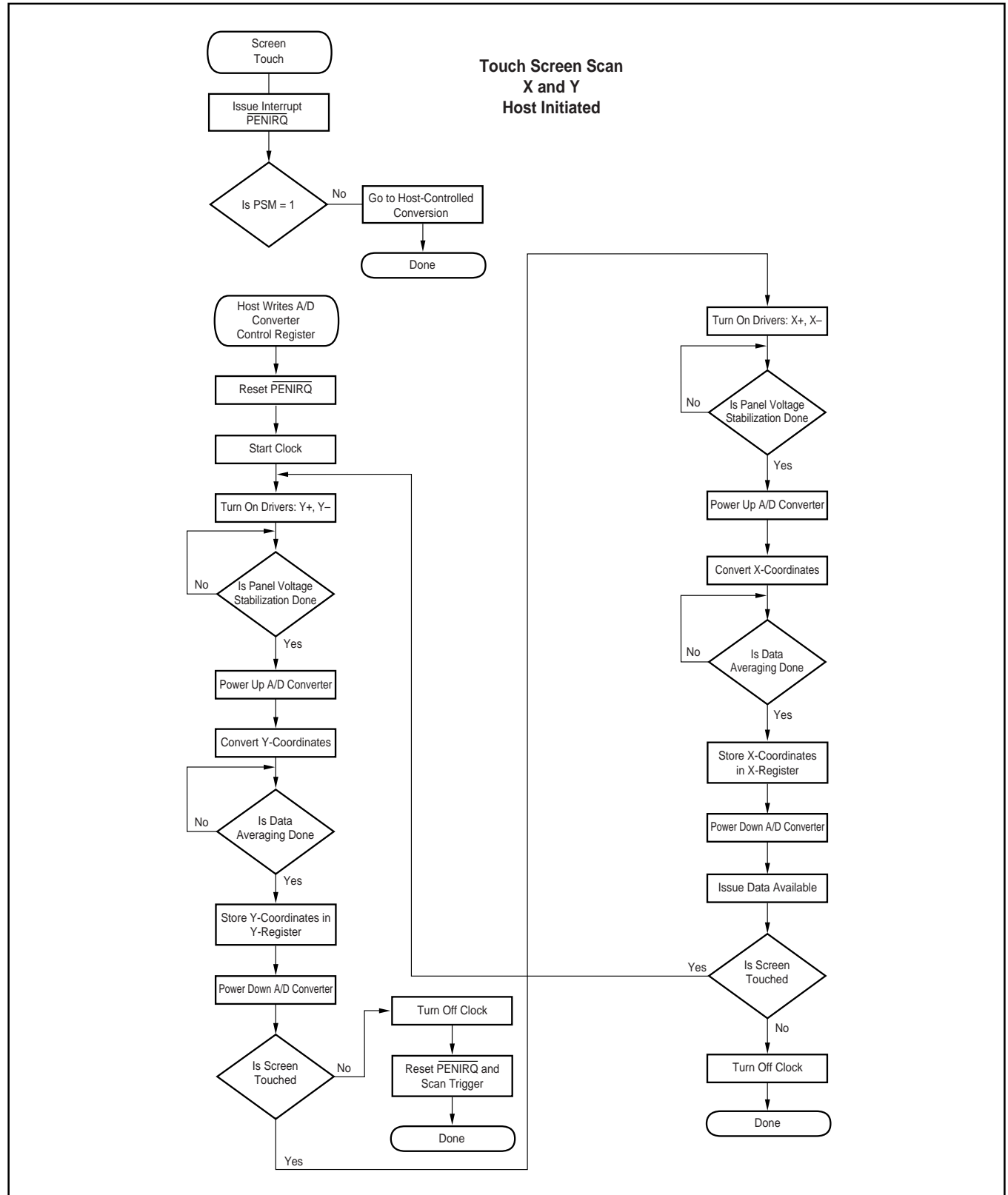

FIGURE 10. X- and Y-Coordinate Touch Screen Scan, Initiated by Host.

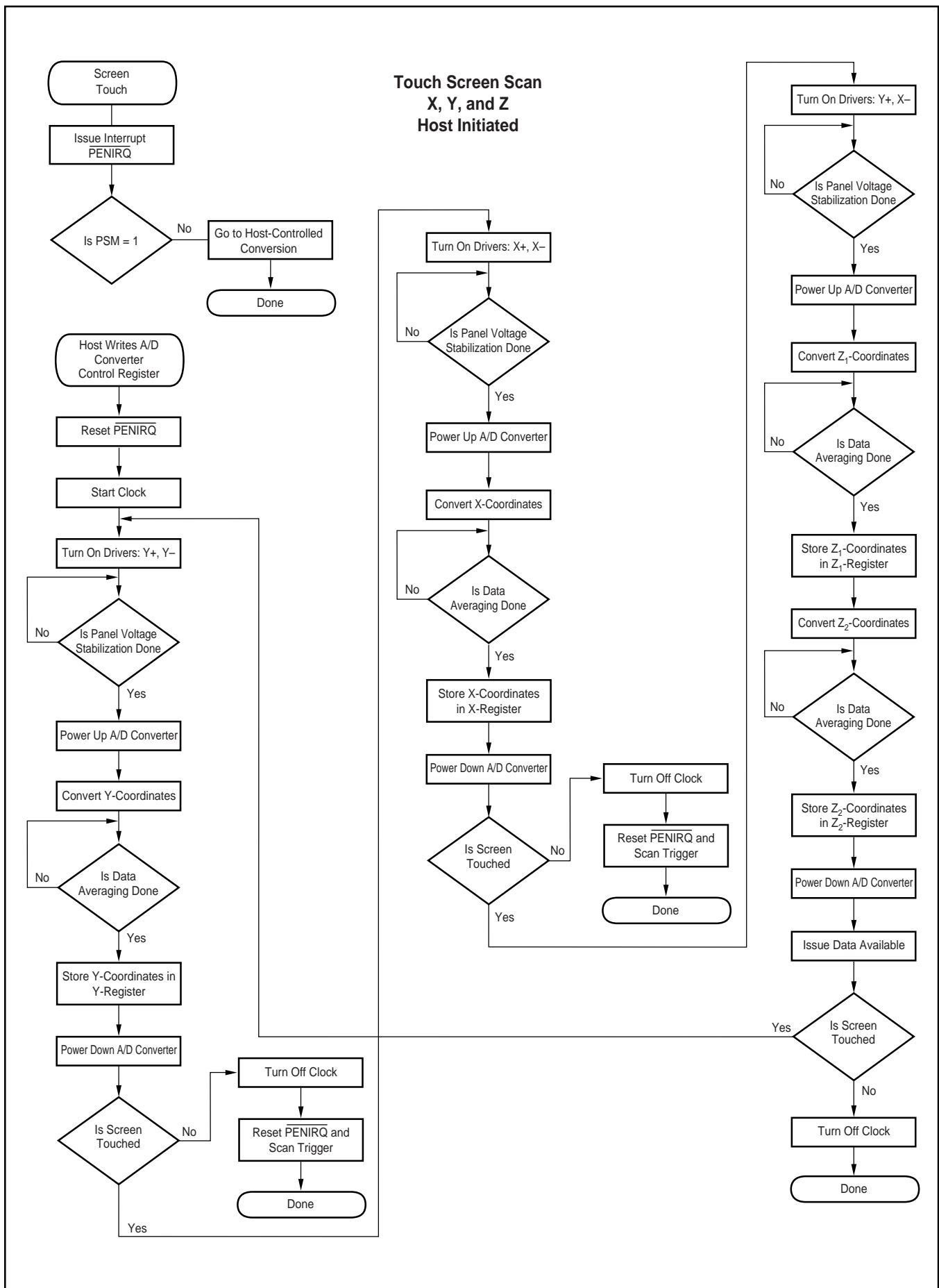

FIGURE 11. X-, Y-, and Z-Coordinate Touch Screen Scan, Initiated by Host.

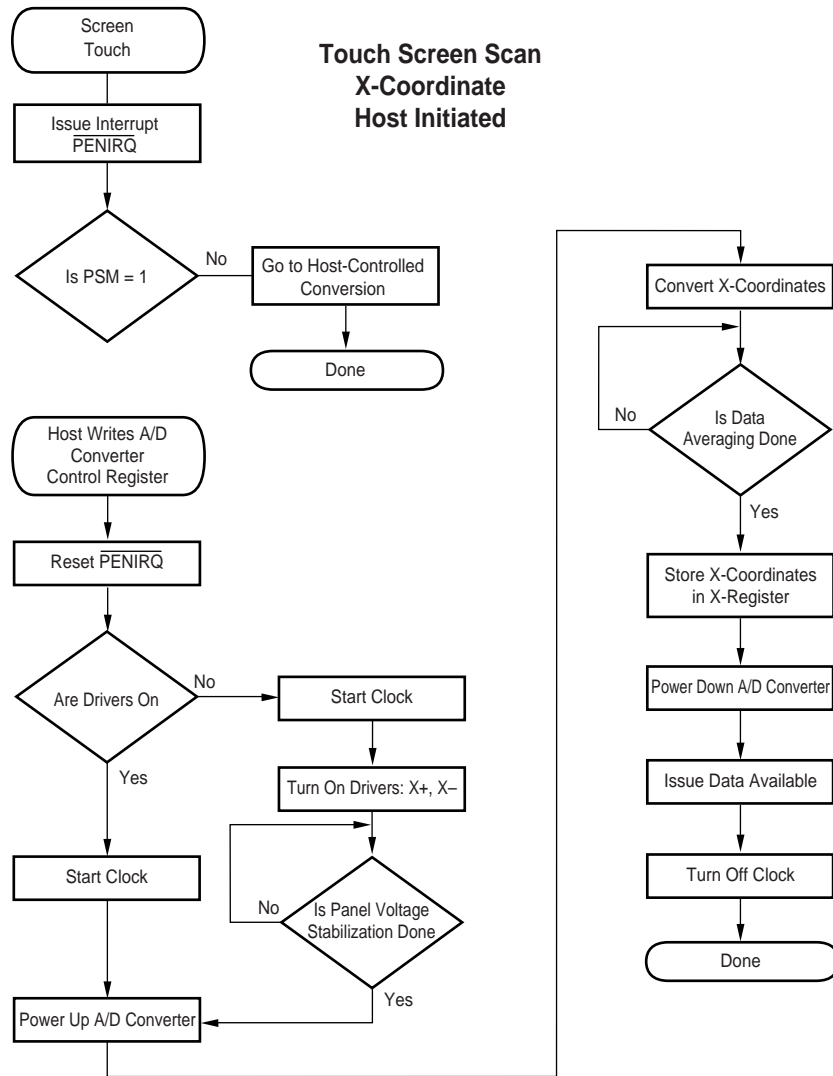

FIGURE 12. X-Coordinate Reading Initiated by Host.

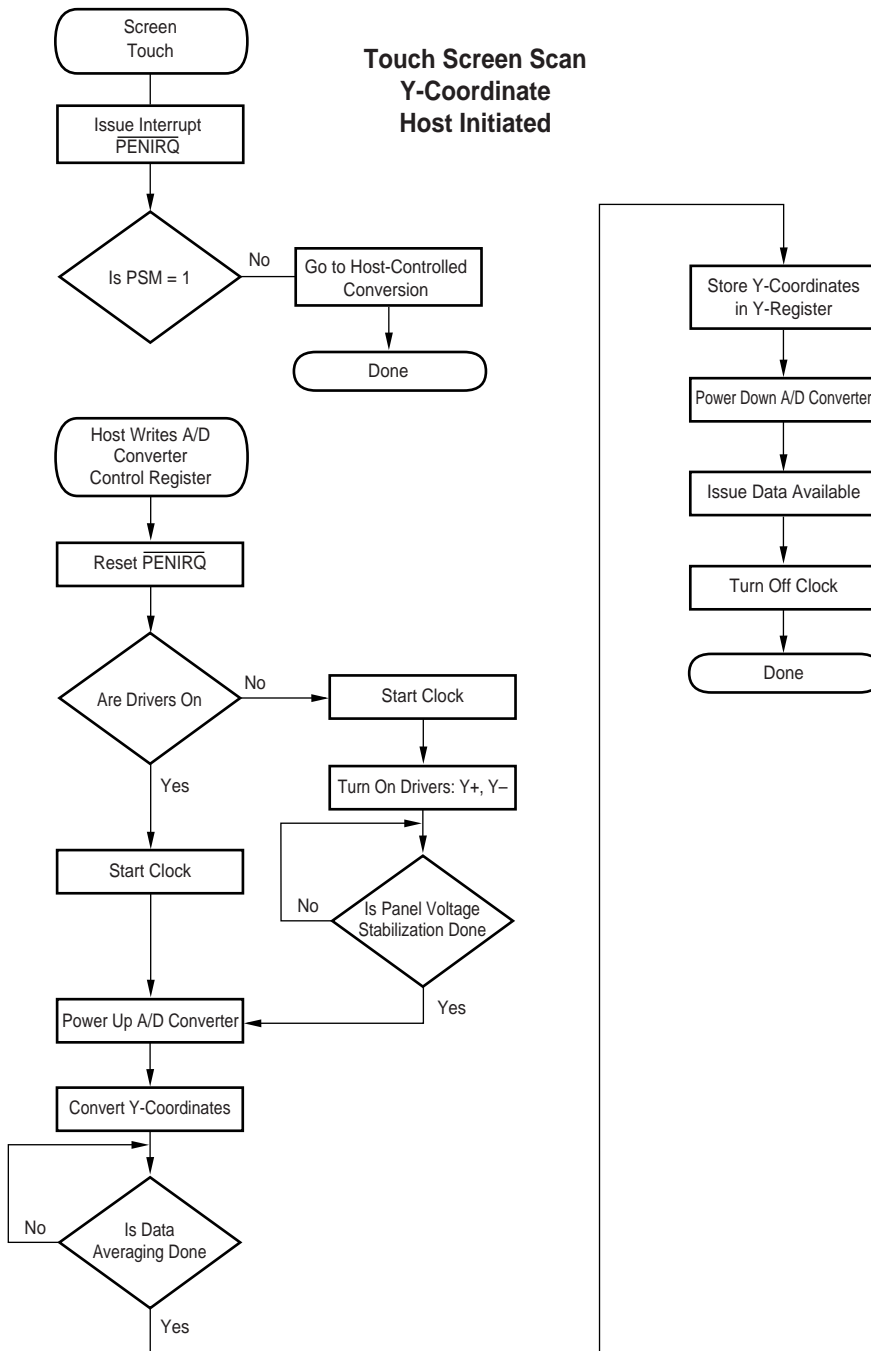

FIGURE 13. Y-Coordinate Reading Initiated by Host.

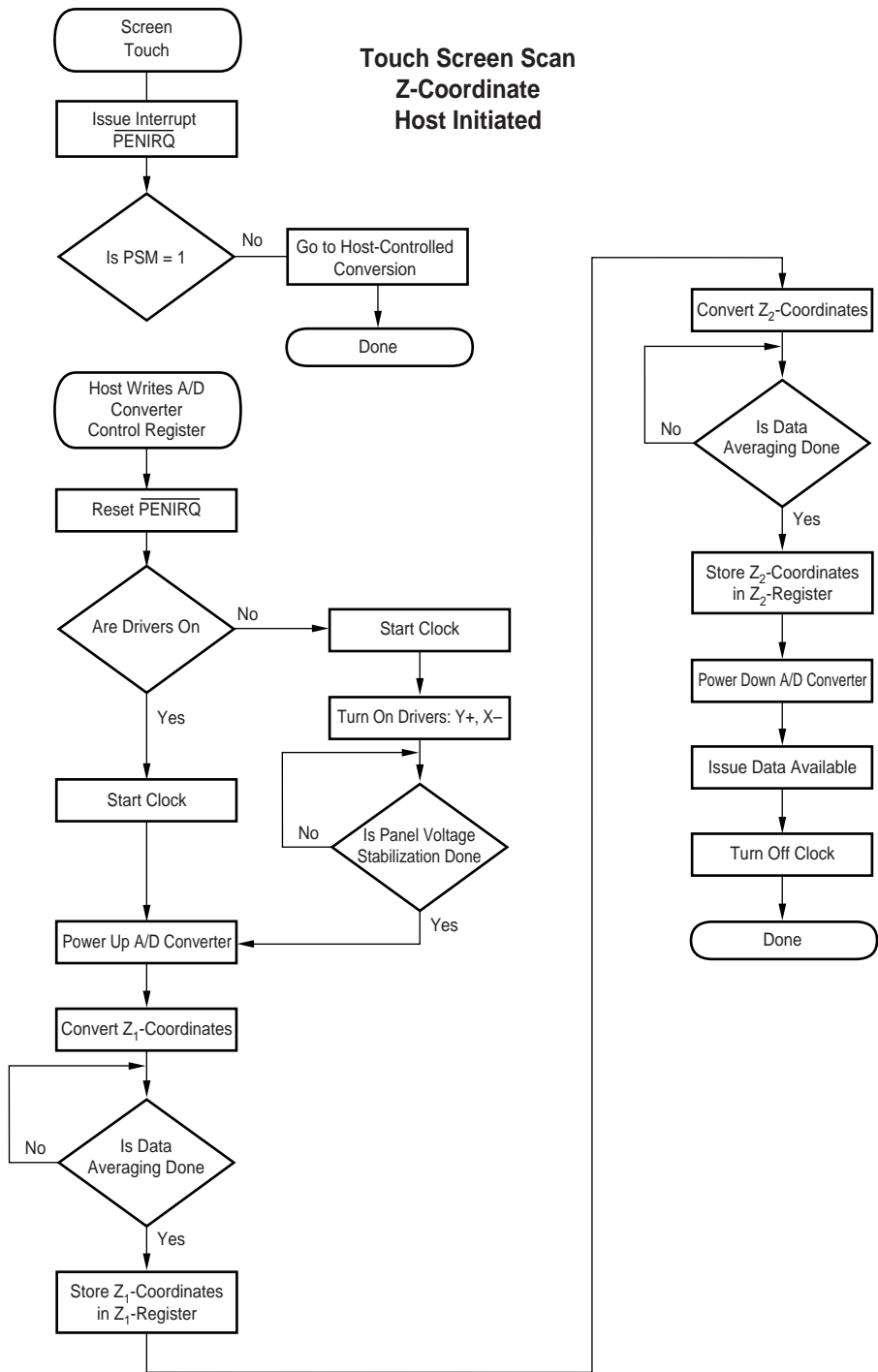

FIGURE 14. Z-Coordinate Reading Initiated by Host.

Conversion Controlled by the Host

In this mode, the TSC2000 will detect when the touch panel is touched and cause the $\overline{\text{PENIRQ}}$ line to go LOW. The host will recognize the interrupt request. Instead of starting a sequence in the TSC2000 which then reads each coordinate in turn, the host now must control all aspects of the conversion. Generally, upon receiving the interrupt request, the host will turn on the Y-drivers. After waiting for the settling time, the host will then address the TSC2000 again, this time requesting an X-coordinate conversion.

The process is then repeated for Y- and Z-coordinates. The processes are outlined in Figures 15 through 17.

The time needed to convert any single coordinate under host control (not including the time needed to send the command over the SPI bus) is given by:

$$t_{\text{COORDINATE}} = 2.125\mu\text{s} + t_{\text{PVS}} + N_{\text{AVG}} \left(N_{\text{BITS}} \cdot \frac{1}{f_{\text{CONV}}} + 4.4\mu\text{s} \right) \quad (5)$$

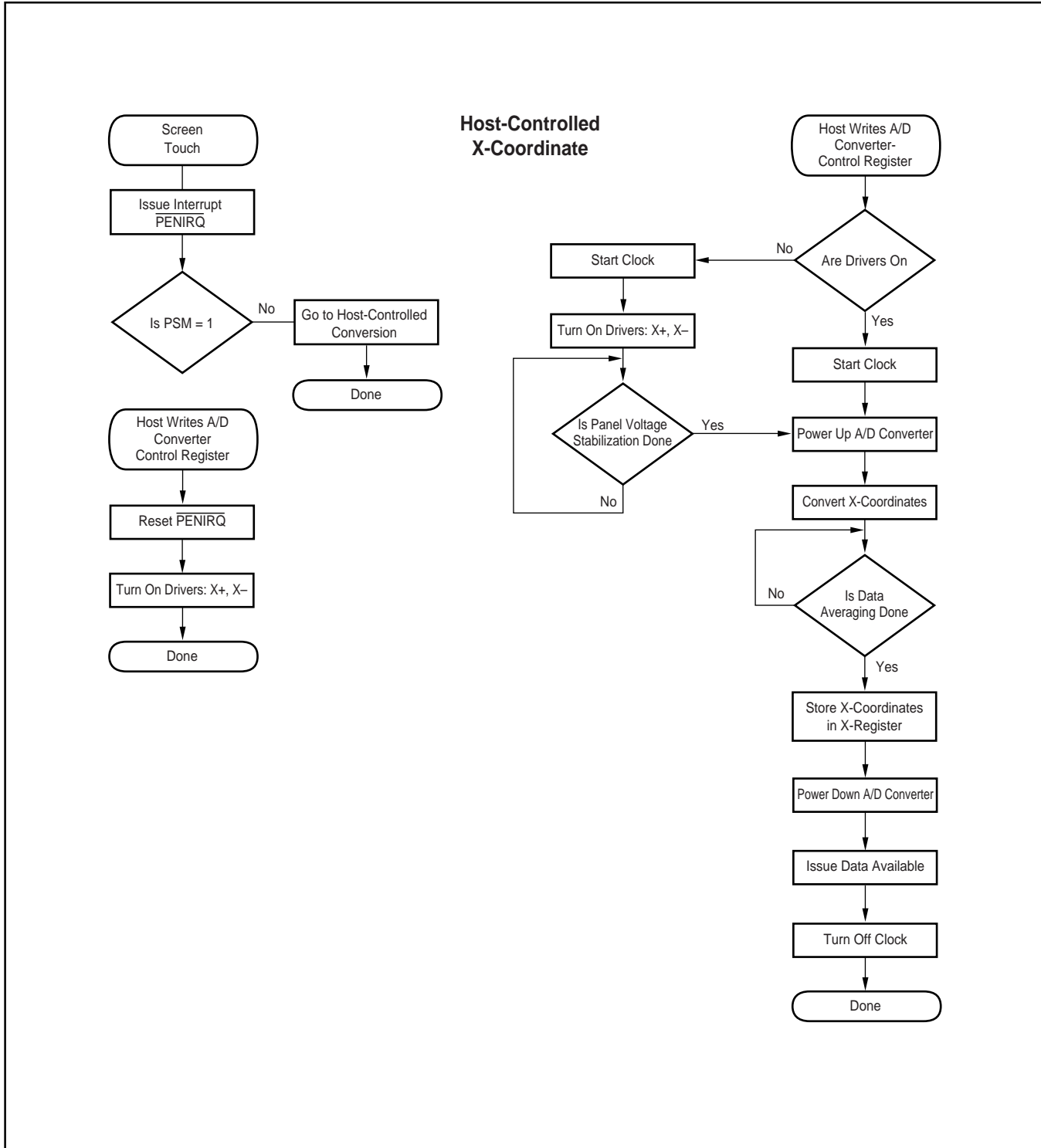

FIGURE 15. X-Coordinate Reading Controlled by Host.

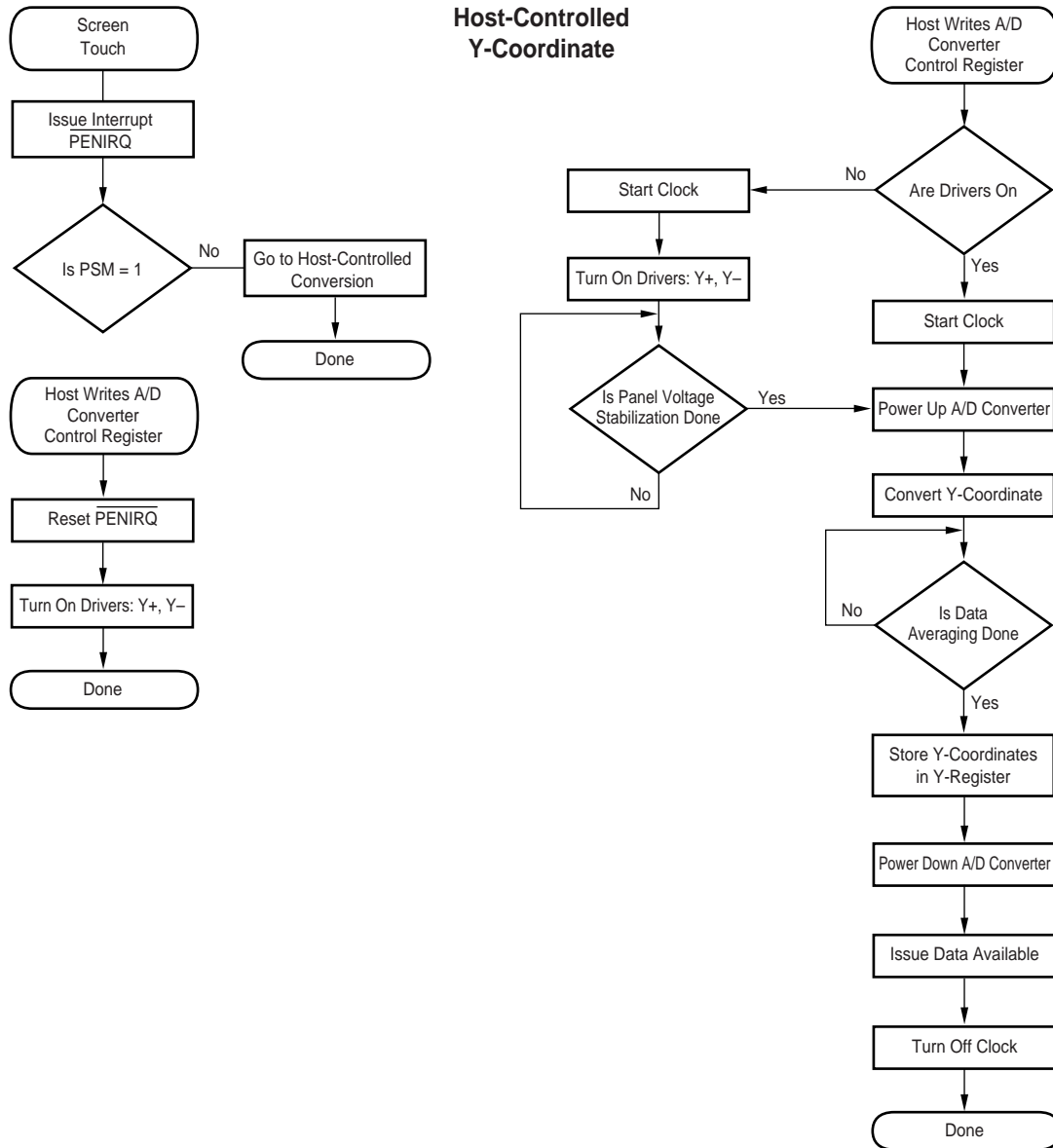

FIGURE 16. Y-Coordinate Reading Controlled by Host.

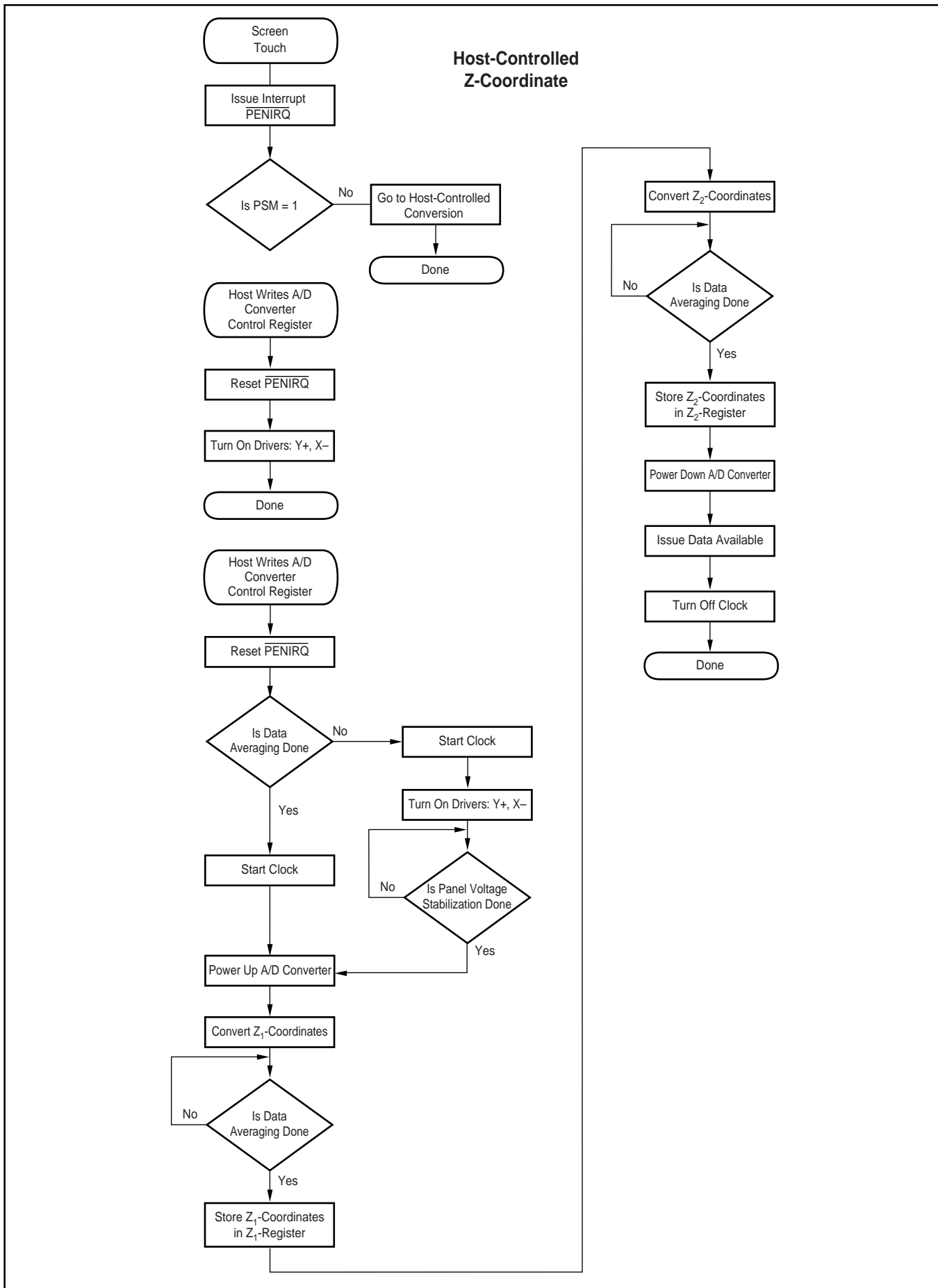

FIGURE 17. Z-Coordinate Reading Controlled by Host.

OPERATION—TEMPERATURE MEASUREMENT

In some applications, such as battery recharging, a measurement of ambient temperature is required. The temperature measurement technique used in the TSC2000 relies on the characteristics of a semiconductor junction operating at a fixed current level. The forward diode voltage (V_{BE}) has a well-defined characteristic versus temperature. The ambient temperature can be predicted in applications by knowing the 25°C value of the V_{BE} voltage and then monitoring the delta of that voltage as the temperature changes.

The TSC2000 offers two modes of temperature measurement. The first mode requires calibration at a known temperature, but only requires a single reading to predict the ambient temperature. A diode, as shown in Figure 18, is used during this measurement cycle. This voltage is typically 600mV at +25°C with a 20µA current through it. The absolute value of this diode voltage can vary a few millivolts; the temperature coefficient (TC) of this voltage is very consistent at -2.1mV/°C. During the final test of the end product, the diode voltage would be stored at a known room temperature, in system memory, for calibration purposes by the user. The result is an equivalent temperature measurement resolution of 0.3°C/LSB. This measurement of what is referred to as Temperature 1 is illustrated in Figure 19.

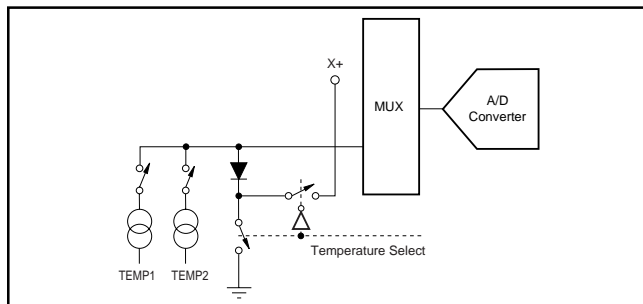

FIGURE 18. Functional Block Diagram of Temperature Measurement Mode.

The second mode does not require a test temperature calibration, but uses a two-measurement (differential) method to eliminate the need for absolute temperature calibration and for achieving 2°C/LSB accuracy. This mode requires a second conversion with a 91 times larger current. The voltage difference between the first (TEMP1) and second (TEMP2) conversion, using 91 times the bias current, will be represented by $kT/q \cdot \ln(N)$, where N is the current ratio = 91, k = Boltzmann's constant ($1.38054 \cdot 10^{-23}$ electrons volts/degrees Kelvin), q = the electron charge ($1.602189 \cdot 10^{-19}$ °C), and T = the temperature in degrees Kelvin. This method can provide much improved absolute temperature measurement, but less resolution of 2°C/LSB. The resultant equation for solving for °K is:

$$^{\circ}\text{K} = \frac{q \cdot \Delta V}{k \cdot \ln(N)} \quad (6)$$

where,

$$\Delta V = V(I_{g1}) - V(I_1) \quad (\text{in mV})$$

$$\therefore ^{\circ}\text{K} = 2.573 \Delta V / \text{mV}$$

$$^{\circ}\text{C} = 2.573 \cdot \Delta V(\text{mV}) - 273^{\circ}\text{K}$$

See Figure 20 for the Temperature 2 measurement.

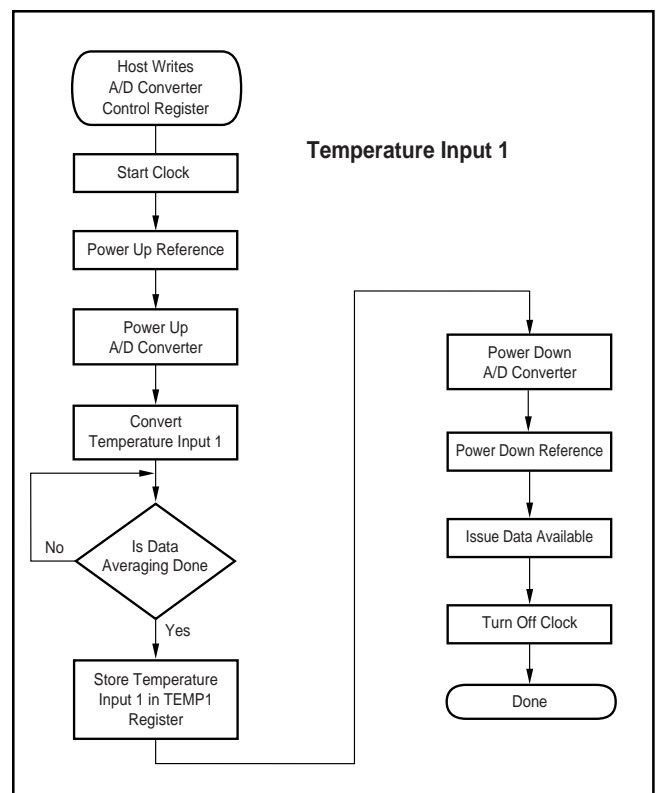

FIGURE 19. Single Temperature Measurement Mode.

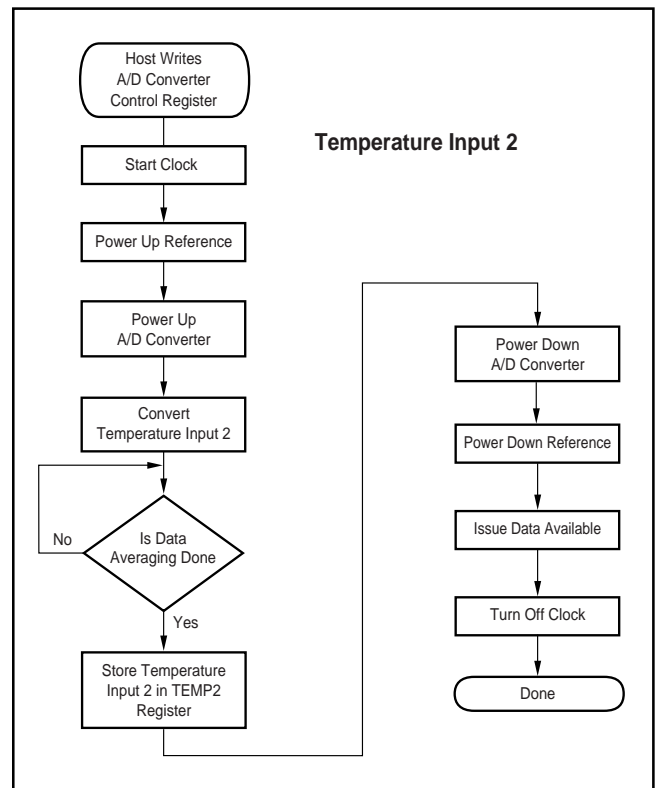

FIGURE 20. Additional Temperature Measurement for Differential Temperature Reading.

OPERATION—BATTERY MEASUREMENT

An added feature of the TSC2000 is the ability to monitor the battery voltage on the other side of a voltage regulator (DC/DC converter), as shown in Figure 21. The V_{BAT1} input is divided down by 4 so that an input range of 0.5V to 6.0V can be measured. Because of the division by 4, this input range would be represented as 0.125V to 1.5V to the A/D converter.

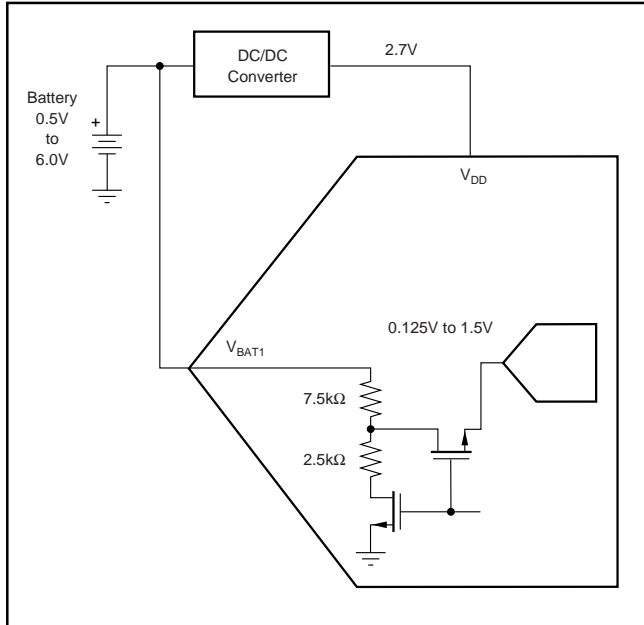

FIGURE 21. Battery Measurement Functional Block Diagram.

The V_{BAT2} input is divided down by 2, so it accommodates an input range of 0.5V to 3.0V, which is represented to the A/D converter as 0.25V to 1.5V. This smaller divider ratio allows for increased resolution. Note that the V_{BAT2} input pin can withstand up to 6V, but this input will only provide accurate measurements within the 0.5V to 3.0V range.

For both battery inputs, the dividers are ON only during the sampling of the battery input, in order to minimize power consumption.

Flowcharts which detail the process of making a battery input reading are shown in Figures 22 and 23.

The time needed to make temperature, auxiliary, or battery measurements is given by:

$$t_{READING} = 2.625\mu s + t_{REF} + N_{AVG} \left(N_{BITS} \cdot \frac{1}{f_{CONV}} + 4.4\mu s \right) \quad (7)$$

where t_{REF} is the reference delay time as given in Table XVII.

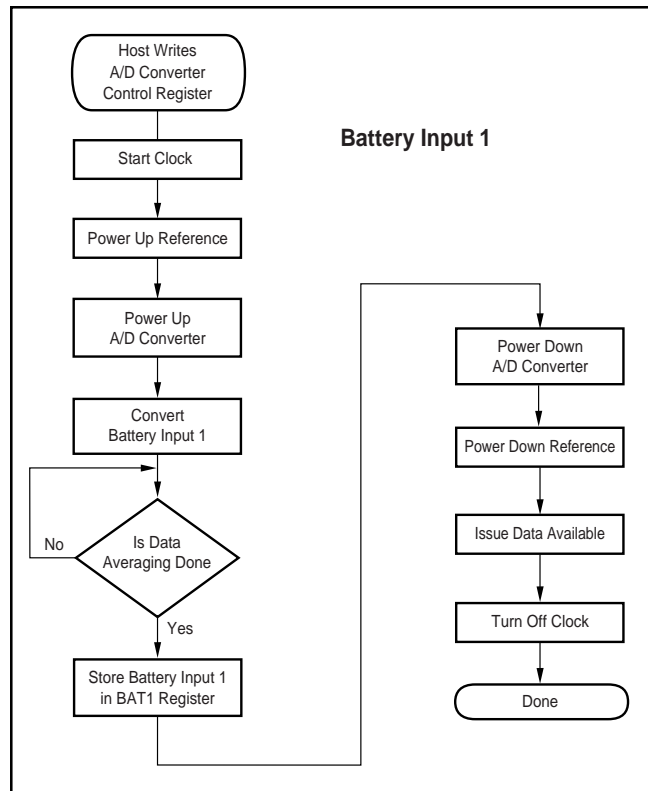

FIGURE 22. V_{BAT1} Measurement Process.

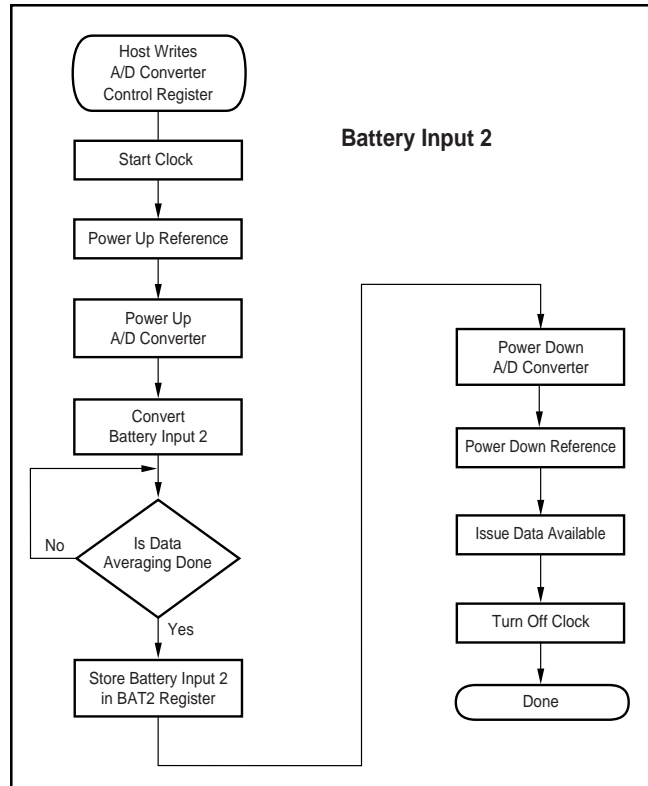

FIGURE 23. V_{BAT2} Measurement Process.

OPERATION—AUXILIARY MEASUREMENT

The two auxiliary voltage inputs can be measured in much the same way as the battery inputs, as shown in Figures 24 and 25. Applications might include external temperature sensing, ambient light monitoring for controlling the back-light, or sensing the current drawn from the battery.

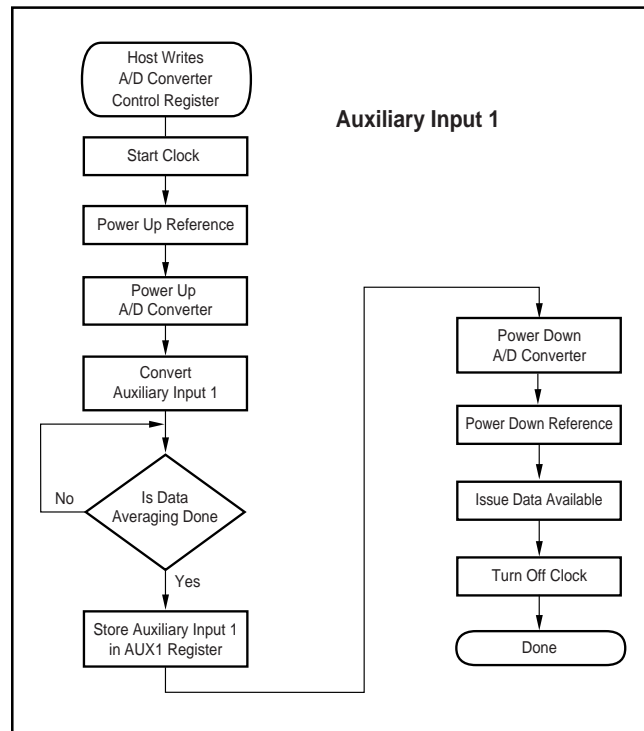

FIGURE 24. AUX1 Measurement Process.

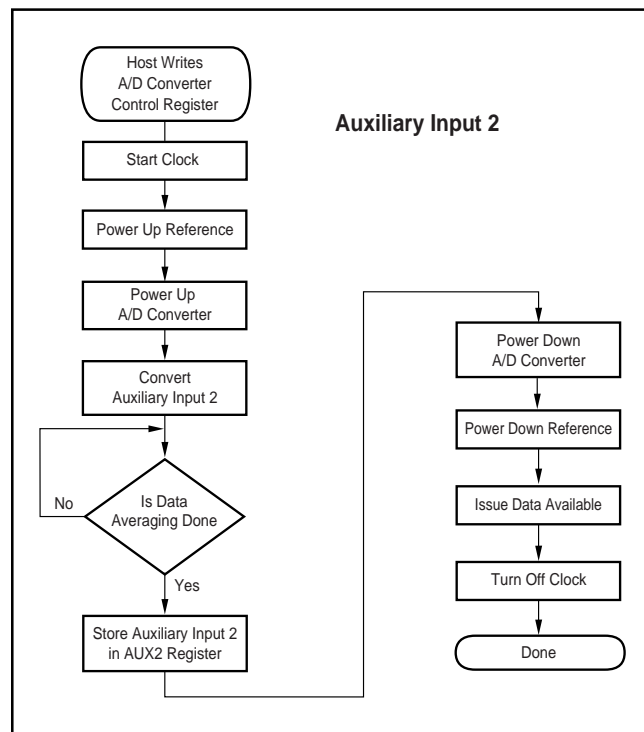

FIGURE 25. AUX2 Measurement Process.

OPERATION—PORT SCAN

If making measurements of all the analog inputs (except the touch screen) is desired on a periodic basis, the Port Scan mode can be used. This mode causes the TSC2000 to sample and convert both battery inputs and both auxiliary inputs. At the end of this cycle, the battery and auxiliary result registers will contain the latest values. Thus, with one write to the TSC2000, the host can cause four different measurements to be made.

The flowchart for this process is shown in Figure 26. The time needed to make a complete port scan is given by:

$$t_{\text{READING}} = 7.5\mu\text{s} + t_{\text{REF}} + 4N_{\text{AVG}} \left(N_{\text{BITS}} \cdot \frac{1}{f_{\text{CONV}}} + 4.4\mu\text{s} \right) \quad (8)$$

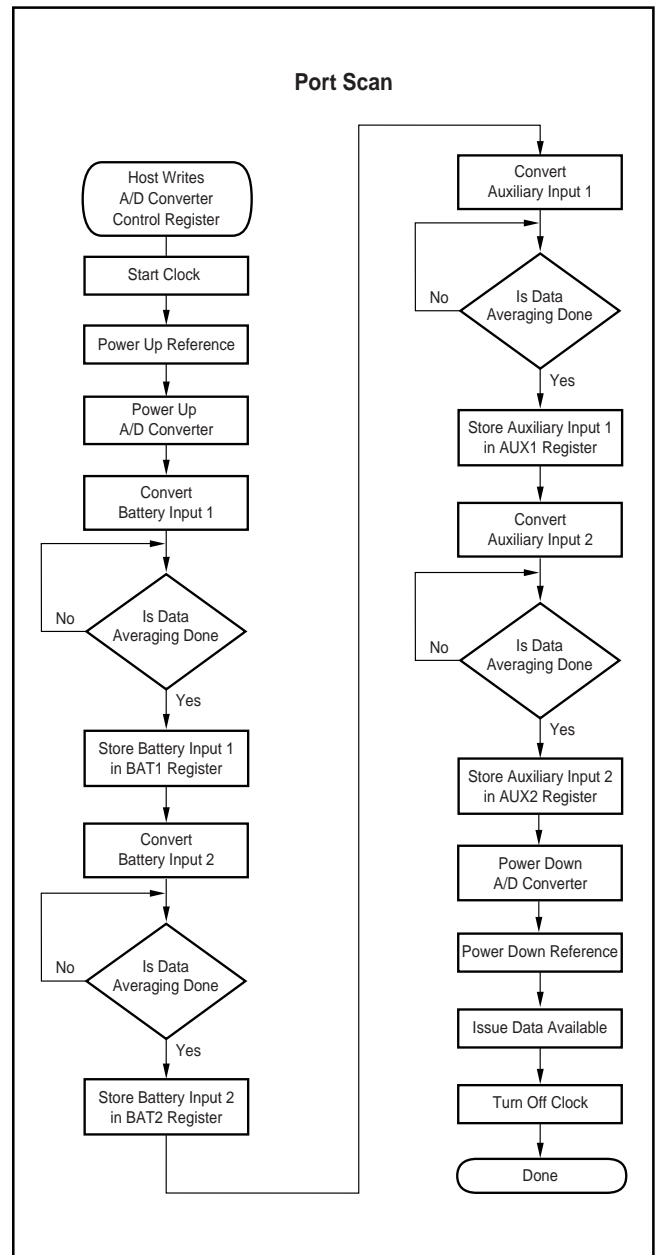

FIGURE 26. Port Scan Mode.

OPERATION—D/A CONVERTER

The TSC2000 has an on-board 8-bit D/A converter, configured as shown in Figure 27. This configuration yields a current sink (A_{OUT}) controlled by the value of a resistor connected between the ARNG pin and ground. The D/A converter has a control register, which controls whether or not the converter is powered up. The 8-bit data is written to the D/A converter through the D/A converter data register.

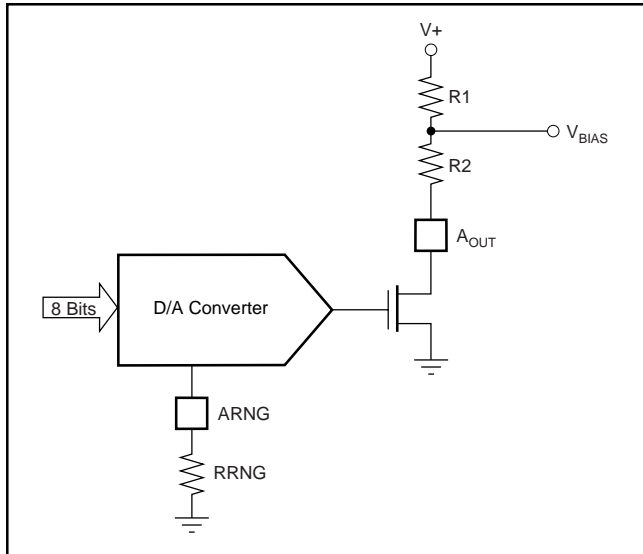

FIGURE 27. D/A Converter Configuration.

This circuit is designed for flexibility in the output voltage at the V_{BIAS} point shown in Figure 27 to accommodate the widely varying requirements for LCD contrast control bias. V_+ can be a higher voltage than the supply voltage for the TSC2000. The only restriction is that the voltage on the A_{OUT} pin can never go above the absolute maximum ratings for the device, and should stay above 1.5V for linear operation.

The D/A converter has an output sink range which is limited to 1mA. This range can be adjusted by changing the value of RRNG shown in Figure 27. As this D/A converter is not designed to be a precision device, the actual output current range can vary as much as $\pm 20\%$. Furthermore, the current output will change due to variations in temperature; the D/A converter has a temperature coefficient of approximately $-2\mu A/^\circ C$. To set the full-scale current, RRNG can be determined from the graph shown in Figure 28.

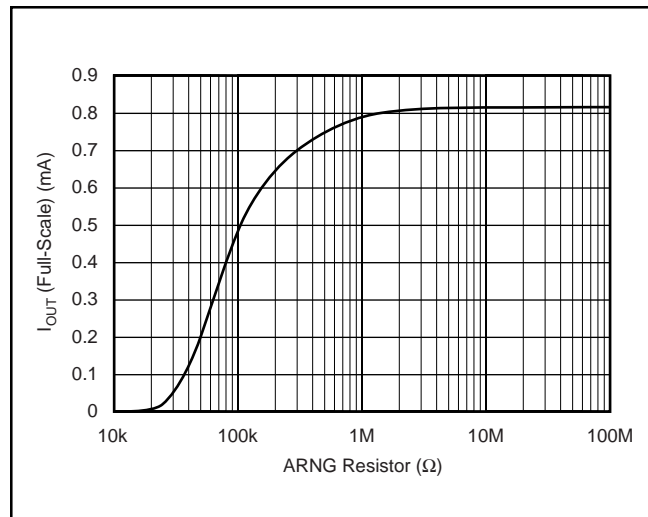

FIGURE 28. D/A Converter Output Current Range versus RRNG Resistor Value.

For example, consider an LCD that has a contrast control voltage V_{BIAS} that can range from 2V to 4V, that draws $400\mu A$ when used, and an available +5V supply. Note that this is higher than the TSC2000 supply voltage, but it is within the absolute maximum ratings.

The maximum V_{BIAS} voltage is 4V, and this occurs when the D/A converter current is at its full scale value, I_{MAX} . In this case, $5V - 4V = 1V$ will be dropped across R_1 , so $R_1 = 1V/400\mu A = 2.5k\Omega$.

The minimum V_{BIAS} is 2V, which occurs when the D/A converter current is at its full scale value, I_{MAX} . In this case, $5V - 2V = 3V$ will be dropped across R_1 , so the current through R_1 will be $3V/2.5k = 1.2mA$. This current is $I_{MAX} + I_{LOAD} = I_{MAX} + 400\mu A$, so I_{MAX} must be set to $800\mu A$. Looking at Figure 28, this means that RRNG should be around $1M\Omega$.

Since the voltage at the A_{OUT} pin should not go below 1.5V, this limits the voltage at the bottom of R_2 to be 1.5V minimum; this occurs when the D/A converter is providing its maximum current, I_{MAX} . In this case, $I_{MAX} + I_{LOAD}$ flows through R_1 , and I_{MAX} flows through R_2 . Thus,

$$R_2 I_{MAX} + R_1 (I_{MAX} + I_{LOAD}) = 5V - 1.5V = 3.5V$$

We already have found $R_1 = 2.5k\Omega$, $I_{MAX} = 800\mu A$, $I_{LOAD} = 400\mu A$, so we can solve this for R_2 and find that it should be 625Ω .

In the previous example, when the D/A converter current is zero, the voltage on the A_{OUT} pin will rise above the TSC2000 supply voltage. This is not a problem, however, since V_+ was within the absolute maximum ratings of the TSC2000, so no special precautions are necessary. Many LCD displays require voltages much higher than the absolute maximum ratings of the TSC2000. In this case, the addition of an NPN transistor, as shown in Figure 29, will protect the A_{OUT} pin from damage.

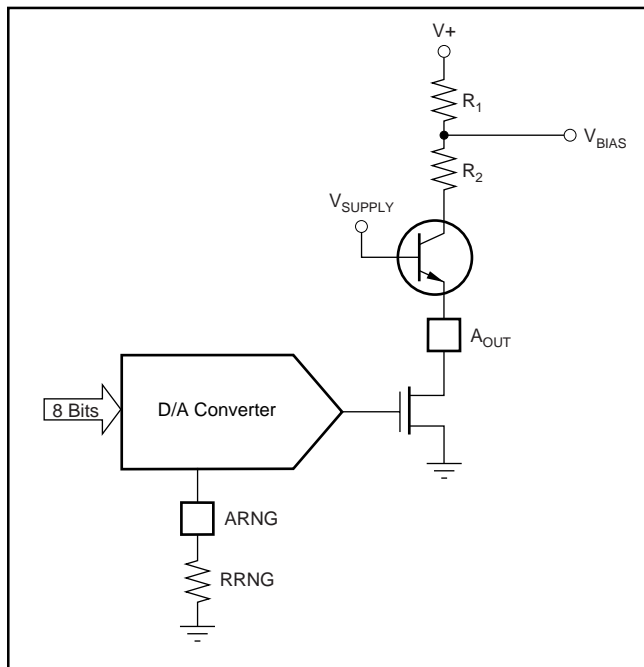

FIGURE 29. D/A Converter Circuit when Using V_+ Higher than V_{SUPPLY} .

LAYOUT

The following layout suggestions should provide optimum performance from the TSC2000. However, many portable applications have conflicting requirements concerning power, cost, size, and weight. In general, most portable devices have fairly “clean” power and grounds because most of the internal components are very low power. This situation would mean less bypassing for the converter’s power and less concern regarding grounding. Still, each situation is unique and the following suggestions should be reviewed carefully.

For optimum performance, care should be taken with the physical layout of the TSC2000 circuitry. The basic SAR architecture is sensitive to glitches or sudden changes on the power supply, reference, ground connections, and digital inputs that occur just prior to latching the output of the analog comparator. Therefore, during any single conversion for an ‘n-bit’ SAR converter, there are n ‘windows’ in which large external transient voltages can easily affect the conversion

result. Such glitches might originate from switching power supplies, nearby digital logic, and high power devices. The degree of error in the digital output depends on the reference voltage, layout, and the exact timing of the external event. The error can change if the external event changes in time with respect to the SCL input.

With this in mind, power to the TSC2000 should be clean and well bypassed. A 0.1 μ F ceramic bypass capacitor should be placed as close to the device as possible. A 1 μ F to 10 μ F capacitor may also be needed if the impedance of the connection between + V_{DD} and the power supply is HIGH.

A bypass capacitor is generally not needed on the reference pin because the reference is buffered by an internal op amp. If an external reference voltage originates from an op amp, make sure that it can drive any bypass capacitor that is used without oscillation.

The TSC2000 architecture offers no inherent rejection of noise or voltage variation in regards to using an external reference input. This is of particular concern when the reference input is tied to the power supply. Any noise and ripple from the supply will appear directly in the digital results. While high frequency noise can be filtered out, voltage variation due to line frequency (50Hz or 60Hz) can be difficult to remove.

The GND pin should be connected to a clean ground point. In many cases, this will be the “analog” ground. Avoid connections which are too near the grounding point of a microcontroller or digital signal processor. If needed, run a ground trace directly from the converter to the power supply entry or battery connection point. The ideal layout will include an analog ground plane dedicated to the converter and associated analog circuitry.

In the specific case of use with a resistive touch screen, care should be taken with the connection between the converter and the touch screen. Since resistive touch screens have fairly low resistance, the interconnection should be as short and robust as possible. Loose connections can be a source of error when the contact resistance changes with flexing or vibrations.

As indicated previously, noise can be a major source of error in touch screen applications (e.g., applications that require a back-lit LCD panel). This EMI noise can be coupled through the LCD panel to the touch screen and cause “flickering” of the converted data. Several things can be done to reduce this error, such as utilizing a touch screen with a bottom-side metal layer connected to ground. This will couple the majority of noise to ground. Additionally, filtering capacitors, from Y_+ , Y_- , X_+ , and X_- to ground, can also help. Note, however, that the use of these capacitors will increase screen settling time and require longer panel voltage stabilization times, as well as increased precharge and sense times for the \overline{PENIRQ} circuitry of the TSC2000.

PW (R-PDSO-G**)

PLASTIC SMALL-OUTLINE PACKAGE

14 PINS SHOWN

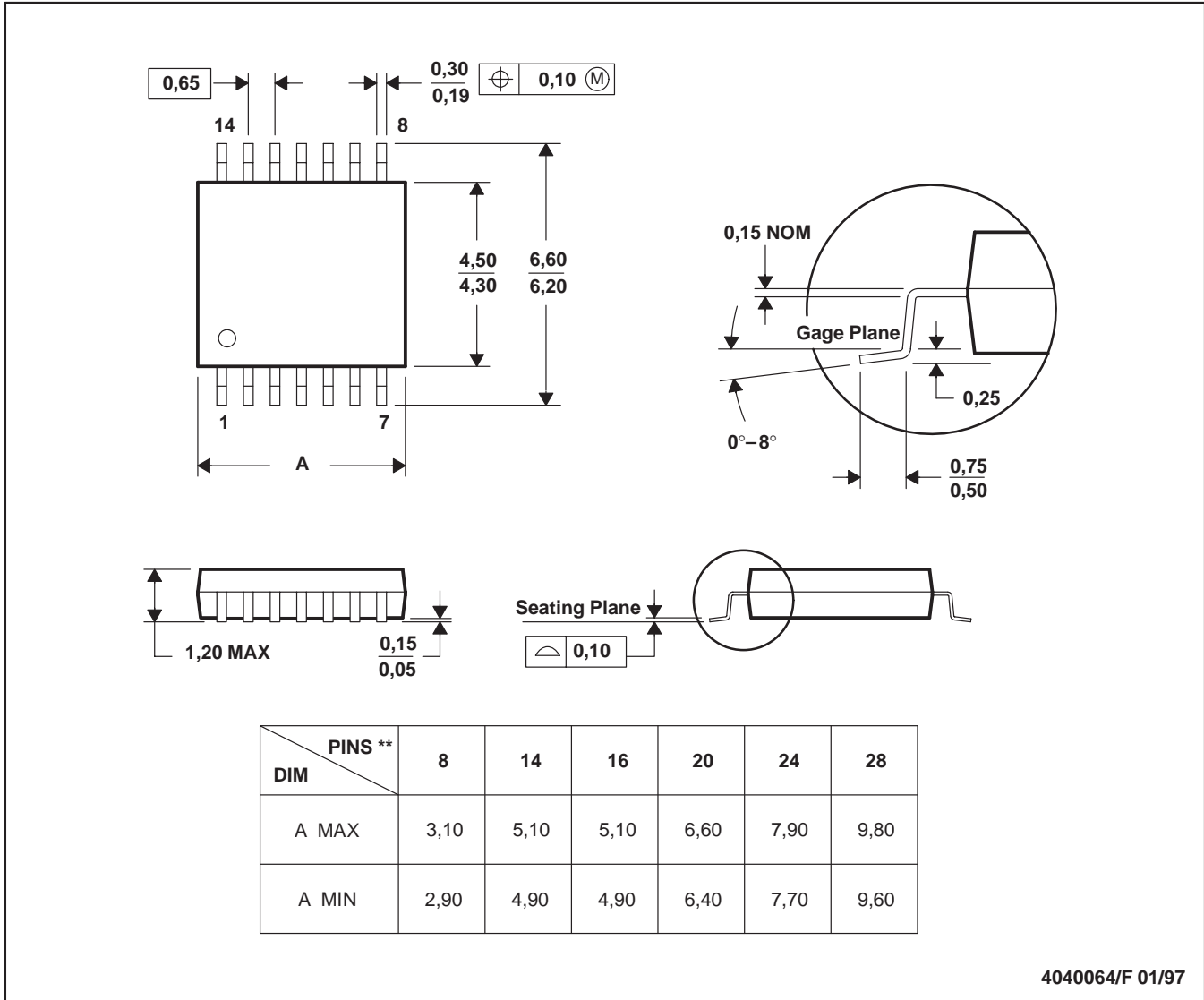

- NOTES: A. All linear dimensions are in millimeters.
 B. This drawing is subject to change without notice.
 C. Body dimensions do not include mold flash or protrusion not to exceed 0,15.
 D. Falls within JEDEC MO-153

IMPORTANT NOTICE

Texas Instruments Incorporated and its subsidiaries (TI) reserve the right to make corrections, modifications, enhancements, improvements, and other changes to its products and services at any time and to discontinue any product or service without notice. Customers should obtain the latest relevant information before placing orders and should verify that such information is current and complete. All products are sold subject to TI's terms and conditions of sale supplied at the time of order acknowledgment.

TI warrants performance of its hardware products to the specifications applicable at the time of sale in accordance with TI's standard warranty. Testing and other quality control techniques are used to the extent TI deems necessary to support this warranty. Except where mandated by government requirements, testing of all parameters of each product is not necessarily performed.

TI assumes no liability for applications assistance or customer product design. Customers are responsible for their products and applications using TI components. To minimize the risks associated with customer products and applications, customers should provide adequate design and operating safeguards.

TI does not warrant or represent that any license, either express or implied, is granted under any TI patent right, copyright, mask work right, or other TI intellectual property right relating to any combination, machine, or process in which TI products or services are used. Information published by TI regarding third-party products or services does not constitute a license from TI to use such products or services or a warranty or endorsement thereof. Use of such information may require a license from a third party under the patents or other intellectual property of the third party, or a license from TI under the patents or other intellectual property of TI.

Reproduction of TI information in TI data books or data sheets is permissible only if reproduction is without alteration and is accompanied by all associated warranties, conditions, limitations, and notices. Reproduction of this information with alteration is an unfair and deceptive business practice. TI is not responsible or liable for such altered documentation. Information of third parties may be subject to additional restrictions.

Resale of TI products or services with statements different from or beyond the parameters stated by TI for that product or service voids all express and any implied warranties for the associated TI product or service and is an unfair and deceptive business practice. TI is not responsible or liable for any such statements.

TI products are not authorized for use in safety-critical applications (such as life support) where a failure of the TI product would reasonably be expected to cause severe personal injury or death, unless officers of the parties have executed an agreement specifically governing such use. Buyers represent that they have all necessary expertise in the safety and regulatory ramifications of their applications, and acknowledge and agree that they are solely responsible for all legal, regulatory and safety-related requirements concerning their products and any use of TI products in such safety-critical applications, notwithstanding any applications-related information or support that may be provided by TI. Further, Buyers must fully indemnify TI and its representatives against any damages arising out of the use of TI products in such safety-critical applications.

TI products are neither designed nor intended for use in military/aerospace applications or environments unless the TI products are specifically designated by TI as military-grade or "enhanced plastic." Only products designated by TI as military-grade meet military specifications. Buyers acknowledge and agree that any such use of TI products which TI has not designated as military-grade is solely at the Buyer's risk, and that they are solely responsible for compliance with all legal and regulatory requirements in connection with such use.

TI products are neither designed nor intended for use in automotive applications or environments unless the specific TI products are designated by TI as compliant with ISO/TS 16949 requirements. Buyers acknowledge and agree that, if they use any non-designated products in automotive applications, TI will not be responsible for any failure to meet such requirements.

Following are URLs where you can obtain information on other Texas Instruments products and application solutions:

Products

| | |
|-----------------------------|--|
| Amplifiers | amplifier.ti.com |
| Data Converters | dataconverter.ti.com |
| DSP | dsp.ti.com |
| Clocks and Timers | www.ti.com/clocks |
| Interface | interface.ti.com |
| Logic | logic.ti.com |
| Power Mgmt | power.ti.com |
| Microcontrollers | microcontroller.ti.com |
| RFID | www.ti-rfid.com |
| RF/IF and ZigBee® Solutions | www.ti.com/lprf |

Applications

| | |
|--------------------|--|
| Audio | www.ti.com/audio |
| Automotive | www.ti.com/automotive |
| Broadband | www.ti.com/broadband |
| Digital Control | www.ti.com/digitalcontrol |
| Medical | www.ti.com/medical |
| Military | www.ti.com/military |
| Optical Networking | www.ti.com/opticalnetwork |
| Security | www.ti.com/security |
| Telephony | www.ti.com/telephony |
| Video & Imaging | www.ti.com/video |
| Wireless | www.ti.com/wireless |

Mailing Address: Texas Instruments, Post Office Box 655303, Dallas, Texas 75265
Copyright © 2008, Texas Instruments Incorporated