

# POWERTIP TECH. CORP.

DISPLAY DEVICES FOR BETTER ELECTRONIC DESIGN

## Specification For Approval

Customer : \_\_\_\_\_

Model Type : LCD Module

Sample Code : PC1602LRU-ISO-E-SA

Mass Production Code : \_\_\_\_\_

Edit : A

Customer Sign	Sales Sign	Approved By	Prepared By

# CONTENTS

## 1.SPECIFICATIONS

- 1.1 Features
- 1.2 Mechanical Specifications
- 1.3 Absolute Maximum Ratings
- 1.4 DC Electrical Characteristics
- 1.5 Optical Characteristics
- 1.6 Backlight Characteristics

## 2.MODULE STRUCTURE

- 2.1 Counter Drawing
- 2.2 Interface Pin Description
- 2.3 Timing Characteristics
- 2.4 Display Command
- 2.5 Character Pattern



*POWERTIP TECHNOLOGY CORPORATION*

DISPLAY DEVICES FOR BETTER ELECTRONIC DESIGN

# 1. SPECIFICATIONS

## 1.1 Features

- 16-characters, two-lines liquid crystal display of 5\*8 dot matrix + cursor
- 1/16 Duty, 1/4 bias
- STN LCD, positive, yellow green
- Transflective LCD
- 12 o'clock viewing angle
- 8 bits parallel data input
- Built-in LED backlight

## 1.2 Mechanical Specifications

- Outline dimension : 85.0mm(L)\* 32.6mm(W)\*14.5mm max.(H)
- Viewing area : 61.0mm \*15.8mm
- Active area : 56.21mm \*11.5mm
- Dot size : 0.56mm \*0.66mm
- Dot pitch : 0.7mm \*0.6mm
- Character Size : 2.96mm \*5.56mm

## 1.3 Absolute Maximum Ratings

Item	Symbol	Conditions	Min.	Max.	Unit
Power supply Voltage	VDD	-	0	6.5	V
LCD drive Supply voltage	VDD-VO	-	-	13	V
Input voltage	VIN	-	-0.3	VDD+0.3	V
Operating temperature	TOPR	-	0	50	°C
Storage temperature	TSTG	-	-20	60	°C
Humidity*1	HD	-	-	90	%RH

## 1.4 DC Electrical Characteristics

VDD=+5V±10%,VSS=0V,TA=25°C

Item	Symbol	Condition	Min.	Typ.	Max.	Unit
Logic Supply voltage	VDD	-	4.5	5	5.5	V
“H” input voltage	VIH	-	0.8VDD	-	VDD	V
“L” input voltage	VIL	-	0	-	0.2VDD	V
“H” output voltage	VOH	-	VDD-0.3	-	-	V
“L” output voltage	VOL	-	-	-	0.3	V
Supply current	IDD	VDD=5V	-	1.65	-	mA
LCD driving voltage	VOP	VDD-VO	4.23	4.5	4.8	V



**POWERTIP TECHNOLOGY CORPORATION**

DISPLAY DEVICES FOR BETTER ELECTRONIC DESIGN

# 1.5 Optical Characteristics

1/16 duty, 1/4 bias,  $V_{opr}=4.8V$ ,  $T_a=25^{\circ}C$

Item	Symbol	Conditions	Min.	Typ.	Max	Reference
Viewing angle	$\theta$	$C \geq 2.0, \varnothing = 0^{\circ}C$	$30^{\circ}$	-	-	Notes 1 & 2
Contrast	C	$\theta = 5^{\circ}, \varnothing = 0^{\circ}$	-	3	-	Note 3
Response time(rise)	$t_r$	$\theta = 5^{\circ}, \varnothing = 0^{\circ}$	-	200ms	300ms	Note 4
Response time(fall)	$t_f$	$\theta = 5^{\circ}, \varnothing = 0^{\circ}$	-	200ms	300ms	Note 4

Note 1: Definition of angles  $\theta$  and  $\varnothing$

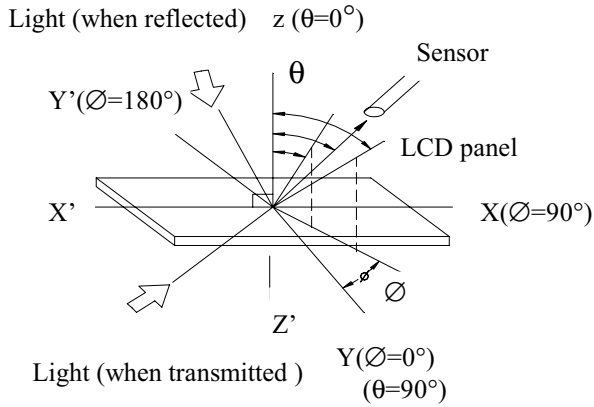

Note 2: Definition of viewing angles  $\theta_1$  and  $\theta_2$

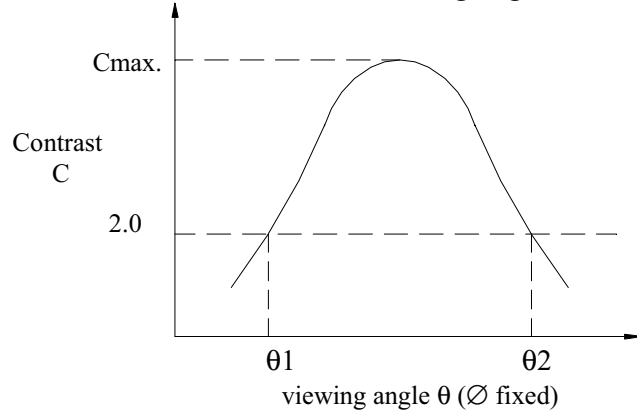

Note : Optimum viewing angle with the naked eye and viewing angle  $\theta$  at  $C_{max}$ . Above are not always the same

Note 3: Definition of contrast C

$$C = \frac{\text{Brightness (reflection) of unselected dot (B2)}}{\text{Brightness (reflection) of selected dot (B1)}}$$

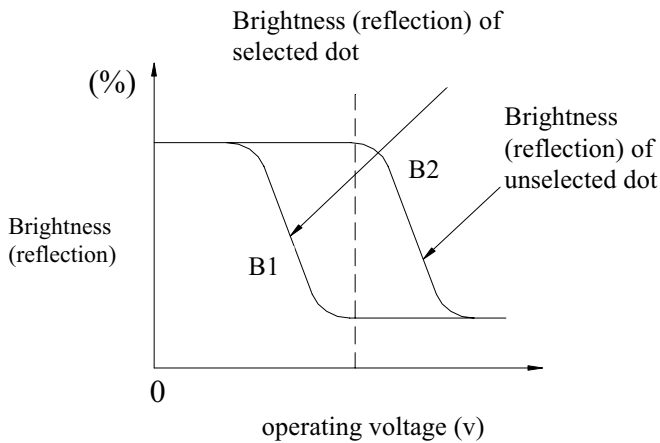

Note 4: Definition of response time

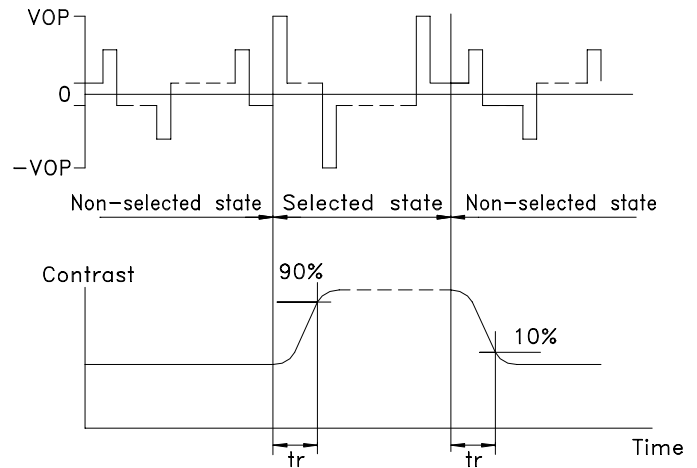

Note: Measured with a transmissive LCD panel which is displayed  $1\text{ cm}^2$

$V_{opr}$  : Operating voltage       $f_{FRM}$  : Frame frequency  
 $t_r$  : Response time (rise)       $t_f$  : Response time (fall)

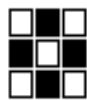

**POWERTIP TECHNOLOGY CORPORATION**  
 DISPLAY DEVICES FOR BETTER ELECTRONIC DESIGN

## 1.6 Backlight Characteristic

The LCD Module is backlight using a edge LED panel

- Maximum Ratings

Item	Symbol	Conditions	Min.	Max.	Unit
Forward current	IF	TA=25°C	-	300	mA
Reverse voltage	VR	TA=25°C	-	8	V
Power dissipation	PO	TA=25°C	-	1.38	W
Operating Temperature	TOPR	-	-20	70	°C
Storage temperature	TSTG	-	-40	80	°C

- Electrical Ratings

Item	Symbol	Condition	Min.	Typ.	Max.	Unit
Forward voltage	VF	IF=120mA	-	4.2	4.6	V
Reverse current	IR	VR=8V	-	-	0.2	mA
Luminous intensity	IV	IF=120mA	120	150	-	cd/m <sup>2</sup>
Wavelength	$\lambda_p$	IF=120mA	571	-	576	nm
Color	Yellow Green					



**POWERTIP TECHNOLOGY CORPORATION**

DISPLAY DEVICES FOR BETTER ELECTRONIC DESIGN

## 2. MODULE STRUCTURE

### 2.1 Counter Drawing

\*See Appendix

### 2.2 Interface Pin Description

Pin No.	Symbol	Signal Description
1	VSS	Signal ground (GND)
2	VDD	Power Supply (5 V)
3	VO	Operating voltage (LCD Driver)
4	RS	Register Selection input High = Data register Low = Instruction register (for write) Busy flag address counter (for read)
5	R/W	Read/Write signal input is used to select the read/write mode High = Read mode, Low = Write mode
6	E	Start enable signal to read or write the data
7~10	DB0 ~ DB3	Four low order bi-directional three-state data bus lines. Use for data transfer between the MPU and the LCD module. These four are not used during 4-bit operation.
11~14	DB4 ~ DB7	Four high order bi-directional three-state data bus lines. Used for data transfer between the MPU and the LCD module. DB7 can be used as a busy flag.
15	A	Power supply LED backlight (+)
16	K	Power supply LED backlight (-)

Contrast Adjust

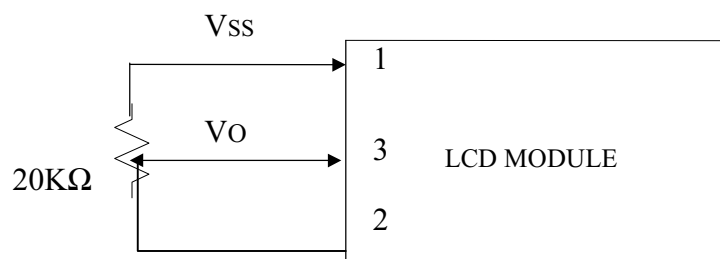

## 2.3 Timing Characteristics

### • Read cycle

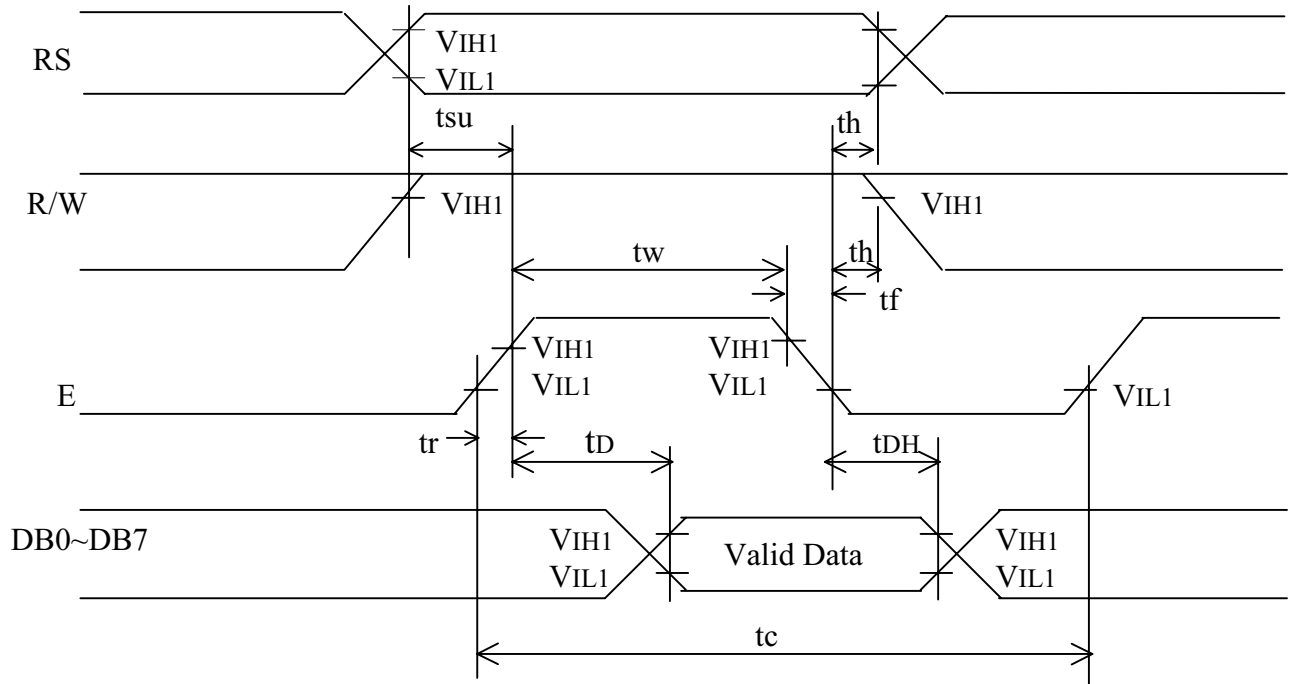

### • Write cycle

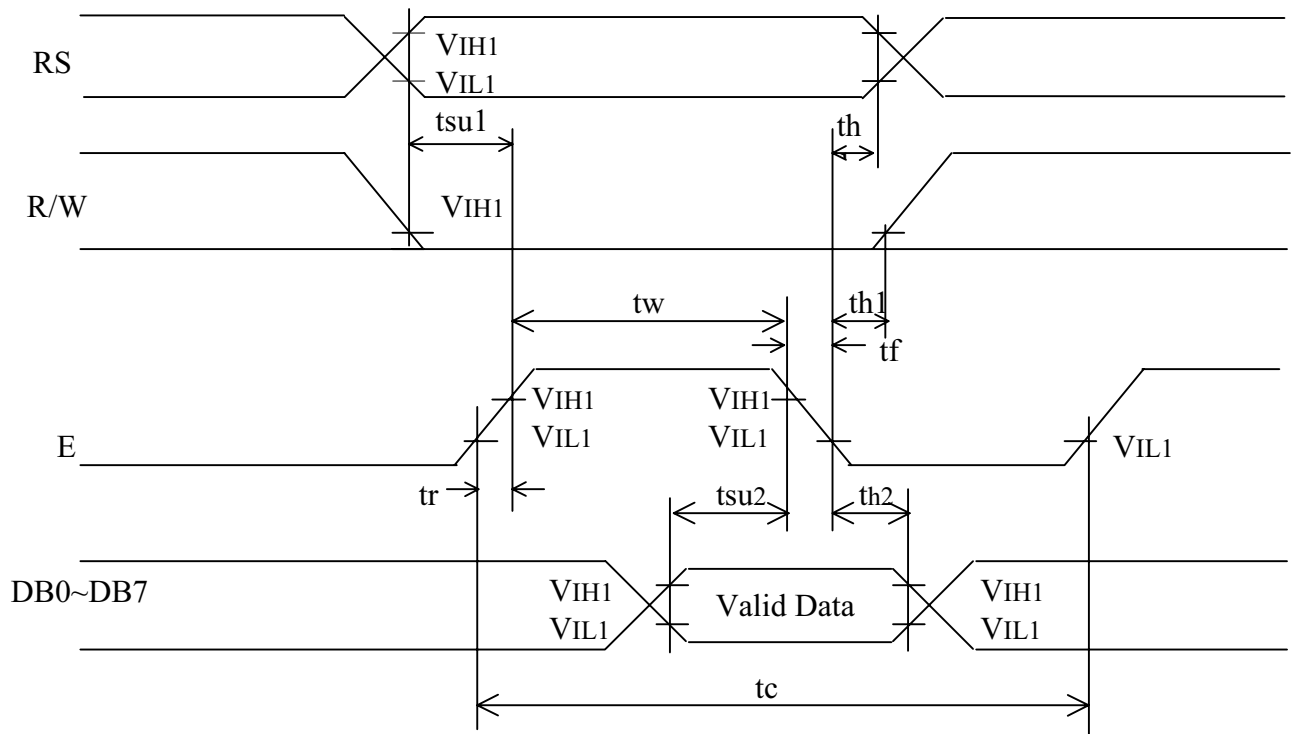

**POWERTIP TECHNOLOGY CORPORATION**

DISPLAY DEVICES FOR BETTER ELECTRONIC DESIGN

- Read cycle

 $V_{DD}=+5V\pm 10\%$ ,  $V_{SS}=0V$ ,  $T_a=25^\circ C$ 

Parameter	Symbol	Min.	Typ.	Max.	Unit	Test Pin
Enable cycle time	tc	500	-	-	ns	E
Enable “H” level pulse width	tw	220	-	-	ns	E
Enable rise /fall time	tr,tf	-	-	25	ns	E
RS,R/W setup time	tsu	40	-	-	ns	RS,R/W
RS,R/W address hold time	th	10	-	-	ns	RS,R/W
Read data output delay time	tD	60	-	120	ns	DB0~DB7
Read data hold time	tDH	20	-	-	ns	DB0~DB7

- Write cycle

Parameter	Symbol	Min.	Typ.	Max.	Unit	Test Pin
Enable cycle time	tc	500	-	-	ns	E
Enable “H” level pulse width	tw	220	-	-	ns	E
Enable rise /fall time	tr,tf	-	-	25	ns	E
RS,R/W setup time	tsu	40	-	-	ns	RS,R/W
RS,R/W address hold time	th	10	-	-	ns	RS,R/W
Read data output delay time	tD	60	-	-	ns	DB0~DB7
Read data hold time	tDH	10	-	-	ns	DB0~DB7



*POWERTIP TECHNOLOGY CORPORATION*

DISPLAY DEVICES FOR BETTER ELECTRONIC DESIGN



## 2.4 Display Command

Instructions	Instruction Code										Description	Execution Time (fosc = 270KHZ)	
	RS	R/W	DB7	DB6	DB5	DB4	DB3	DB2	DB1	DB0			
Clear Display	0	0	0	0	0	0	0	0	0	0	1	Write "20H" to DDRAM. and set DDRAM address to "00H" from AC.	1.52ms
Return Home	0	0	0	0	0	0	0	0	0	1	×	Set DDRAM address to "00H" from AC and return cursor to it's original position if shifted. The contents of DDRAM are not changed.	1.52ms
Entry Mode Set	0	0	0	0	0	0	0	0	1	I/D	SH	Assign cursor moving direction and make shift of entire display enable.	37μs
Display ON/OFF Control	0	0	0	0	0	0	0	1	D	C	B	Sets display (D), cursor(C), and blinking of cursor(B) on/off control bit.	37μs
Cursor or Display Shift	0	0	0	0	0	0	1	S/C	R/L	×	×	Set cursor moving and display shift control bit, and the direction, without changing of DDRAM data.	37μs
Function Set	0	0	0	0	0	1	DL	N	F	×	×	Set interface data length (DL:4 - bit/8-bit), numbers of display line (N: 1-line/2-line), display font type(F:5*8 dots/5*11 dots)	37μs
Set CGRAM Address	0	0	0	1	AC5	AC4	AC3	AC2	AC1	AC0		Set CGRAM address in address counter.	37μs
Set DDRAM Address	0	0	1	AC6	AC5	AC4	AC3	AC2	AC1	AC0		Set DDRAM address in address counter.	37μs
Read Busy Flag and Address	0	1	BF	AC6	AC5	AC4	AC3	AC2	AC1	AC0		Whether during internal operation or not can be known by reading BF. The contents of address counter can also be read.	0μs
Write Data to RAM	1	0	D7	D6	D5	D4	D3	D2	D1	D0		Write data into internal RAM (DDRAM/CGRAM).	43μs
Read Data from RAM	1	1	D7	D6	D5	D4	D3	D2	D1	D0		Read data from internal RAM (DDRAM/CGRAM).	43μs

※ "× ":don't care



**POWERTIP TECHNOLOGY CORPORATION**

DISPLAY DEVICES FOR BETTER ELECTRONIC DESIGN

**2.5 Character Pattern**