

# APDS-9700

## Signal Conditioning IC for Optical Proximity Sensors



## Data Sheet

### Description

APDS-9700 is a signal conditioning IC that enhances the performance and robustness of the optical sensors used for proximity or object detection.

APDS-9700 is a single chip solution that consists of a LED driver circuit, sunlight cancellation and built-in LED stuck high protection circuit integrated into a single chip. APDS-9700 has artificial light immunity and is also operational under the sun. Design flexibility is optimized as APDS-9700 can be paired up with an integrated proximity sensor or discrete pair solution.

APDS-9700 can be disabled to maximize power savings and battery life in applications such as portable or battery-operated devices. The LED current of the optical proximity sensors can be configured to different levels using a limiting resistor at the LEDA pin. APDS-9700 also provides user flexibility to control the pulse width with suitable burst rate, duty cycle and frequency that can reduce power consumption. These low power consumption features makes it also ideal for low power mobile and handheld devices.

APDS-9700 is capable of operating at voltage supply ranging from 2.4 V to 3.6 V. APDS-9700 has two separate output pins for analog and digital outputs. This provides flexibility to use either the analog or digital output (or both) depending on the requirements of the application.

The device is packaged in 8-pin QFN package measuring 0.55mm(H) x 2mm(W) x 2mm(L).

### Ordering Information

Part Number	Package	Shipping Option
APDS-9700-020	Tape & Reel	2500

### Application Support Information

The Application Engineering Group is available to assist you with the application design associated with APDS-9700 module. You can contact them through your local sales representatives for additional details.

### Features

- Low power consumption
  - LED pulse width control
  - Low shut down current
  - External LED drive-current control
- Complete shutdown mode
- Supply voltage : 2.4 V to 3.6 V
- Operational in sunlight conditions up to 100klux(with HSDL-9100)
- Artificial light immunity
- Analog & Digital output available
  - Built in hysteresis comparator for digital output
- LED stuck High protection
- Wide bandwidth Trans-impedance amplifier
- External capacitor and resistor for integration and gain controls
- Flexibility to enhance detection distance up to 200mm with HSDL-9100 or further with external discretes pair
- Small 2mm x 2mm QFN 8-pin package
- Design flexibility to pair with Avago Proximity Sensors or discretes pair solution
- Lead-free & ROHS Compliant

### Applications

- PDA and mobile phones
- Portable and Handheld devices
- Personal Computers/Notebooks
- Amusement/Games/Vending Machines
- Industrial Automation
- Contactless Switches
- Sanitary Automation

### Absolute Maximum Ratings (Ta=25°C)

Parameter	Symbol	Min.	Max.	Units	Conditions
Supply Voltage	V <sub>CC</sub>	0	4.5	V	
Input Logic Voltage	V <sub>i</sub>	0	4.5	V	
Reflow Soldering Temperature			260	°C	

### Recommended Operating Conditions

Parameter	Symbol	Min.	Max.	Units	Conditions
Operating Temperature	T <sub>A</sub>	-40	105	°C	
Storage Temperature	T <sub>s</sub>	-40	125	°C	
Supply Voltage	V <sub>CC</sub>	2.4	3.6	V	

### Electrical & Optical Specifications (Ta=25°C)

Parameters	Symbol	Minimum	Typical	Maximum	Units	Conditions
<b>Input</b>						
Logic High Voltage, LEDON	V <sub>IH</sub>	1.8		V <sub>CC</sub>	V	
Logic High Voltage, ENB	V <sub>IH</sub>	1.8		V <sub>CC</sub>	V	
Logic Low Voltage, LEDON	V <sub>IL</sub>	0		0.3	V	
Logic Low Voltage, ENB	V <sub>IL</sub>	0		0.3	V	
Logic High Input Current, LEDON	I <sub>IH</sub>		0.1	1	µA	V <sub>I</sub> ≥ V <sub>IH</sub>
Logic High Input Current, ENB	I <sub>IH</sub>		0.1	1	µA	V <sub>I</sub> ≥ V <sub>IH</sub>
Logic Low Input Current, LEDON	I <sub>IL</sub>		0.1	1	µA	V <sub>I</sub> ≤ V <sub>IL</sub>
Logic Low Input Current, ENB	I <sub>IL</sub>		0.1	1	µA	V <sub>I</sub> ≤ V <sub>IL</sub>
Shutdown Current	I <sub>SD</sub>		0.3	1	µA	V <sub>CC</sub> =3V, ENB=3V
Idle Current	I <sub>CC</sub>		500	650	µA	V <sub>CC</sub> =3V, ENB=0V
<b>Output</b>						
Digital Output	V <sub>OL</sub>	0		0.3	V	I <sub>DOUT(Low)</sub> = 2mA, V <sub>CC</sub> = 3V
Rise Time(DOUT)	T <sub>R</sub>		1		µs	V <sub>CC</sub> = 3V, R <sub>2</sub> = 10kΩ, Frequency = 10kHz
Fall Time(DOUT)	T <sub>F</sub>		1		µs	V <sub>CC</sub> = 3V, R <sub>2</sub> = 10kΩ, Frequency = 10kHz
<b>Transmitter</b>						
Rise Time (LEDA)	T <sub>R</sub>		40		ns	V <sub>CC</sub> = 3V, I <sub>LED</sub> = 120mA, Freq = 10kHz
Fall Time (LEDA)	T <sub>F</sub>		40		ns	V <sub>CC</sub> = 3V, I <sub>LED</sub> = 120mA, Freq = 10kHz
Max I <sub>LED</sub> Pulse Width	Max-PW		120		µs	V <sub>CC</sub> =3V, ENB=0V
I <sub>LED</sub> Pulse Current	I <sub>LED</sub>		120	300	mA	V <sub>CC</sub> =3V, R <sub>1</sub> = 10Ω

## Electrical & Optical Specification (continued)

### Receiver

Photodiode input current (PD)	$I_{PD}$	0	3	$\mu A$
Current Gain	$I_{PFILT}/I_{PD}$	20		times $V_{CC} = 3.0V$

### Hysteresis Comparator

Hysteresis	$V_{HYS}$	40	mV	$V_{CC} = 3.0V$
Threshold voltage	$V_{TH}$	655	mV	$V_{CC} = 3.0V$

### Sunlight Cancellation

DC Current, PD	$I_{DC}$	100	$\mu A$	$V_{CC} = 3.0V$
----------------	----------	-----	---------	-----------------

## APDS-9700 pin-out and I/O Configurations

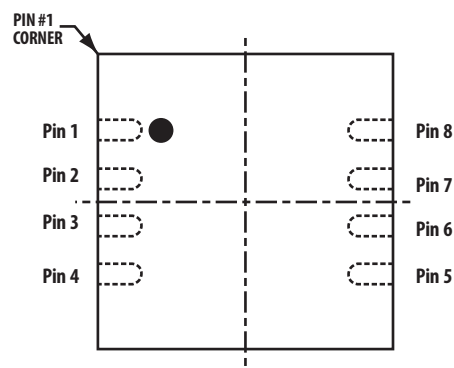

### I/O Pins Configuration Table

Pin	Symbol	Type	Description
1	LEDON	Digital I/P	LED Driver Input LEDA will turn off when LEDON is stuck in high state for > Max-PW
2	ENB	Digital I/P	Power Down Enable ENB = 0 Normal mode operation ENB = 1 Shut down mode
3	DOUT	Digital O/P	Digital Output An open drain output that requires a pull-up resistor of recommended value 10k $\Omega$ DOUT = 0 when $V_{PFILT} > V_{TH}$ DOUT = $V_{CC}$ when $V_{PFILT} < V_{TH}$
4	GND	Ground	Ground
5	PD	Analog I/P	Photo-Detector Input Connect to Cathode of photo-detector (proximity sensor)
6	PFILT	Analog O/P	Analog Output Connect to integration circuit (R3 & CX3)
7	LEDA	Analog O/P	LED Driver Output Connect to Anode of LED (proximity sensor) LEDA will turn off when LEDON is stuck in high state for > Max-PW
8	VCC	Supply	Voltage Supply

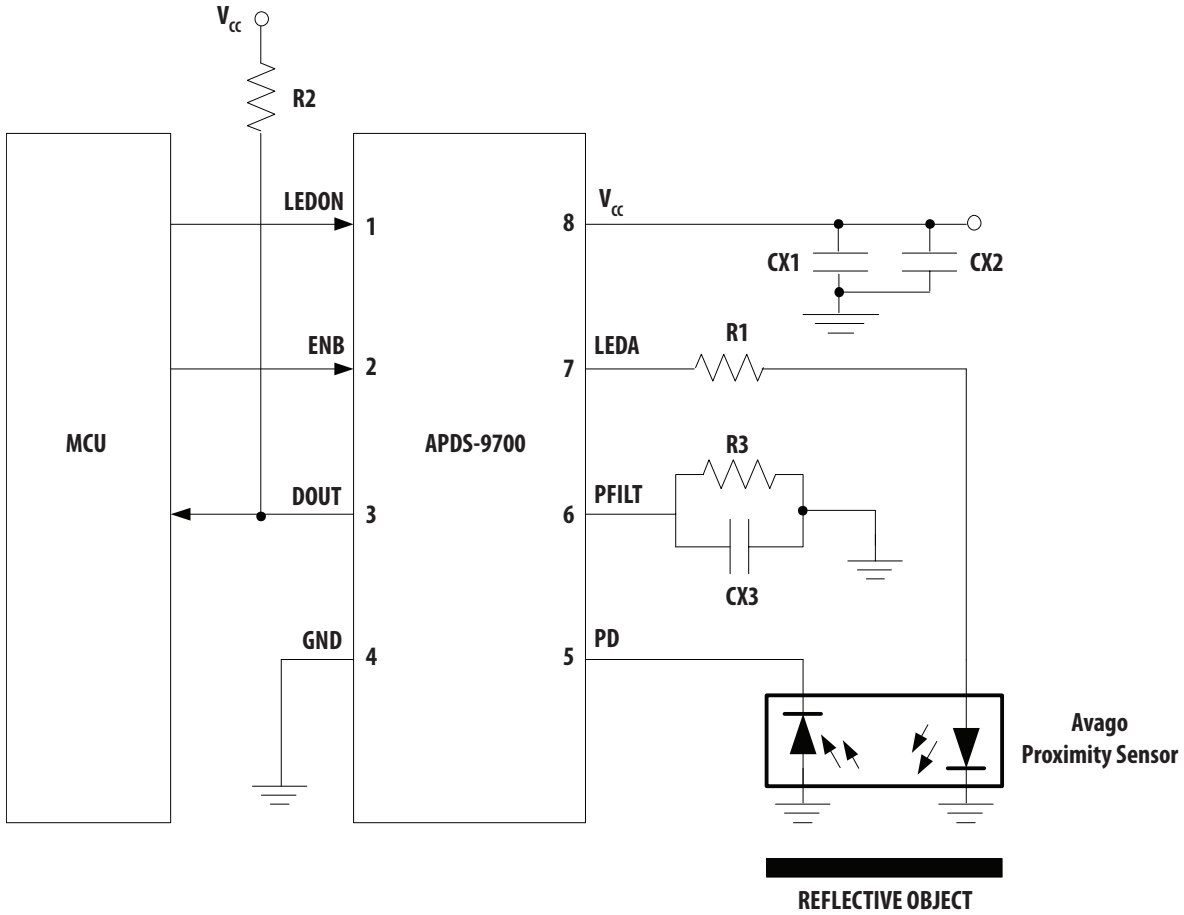

Figure 1. Typical Application Circuit for APDS-9700

Recommended Avago Proximity Sensor	Description
HSDL-9100	Integrated Reflective Proximity Sensor

Component	Recommended Values ( with HSDL-9100)
R1	10 $\Omega$ , 0.125W
R2	10k $\Omega$ , 0.25W
R3	100k $\Omega$ to 500k $\Omega$
CX1	100 nF $\pm$ 20% X 7R, Ceramic,
CX2	6.8 $\mu$ F $\pm$ 20%, Tantalum
CX3	3.3 nF $\pm$ 20% X 7R, Ceramic

# APDS-9700 Block Diagram

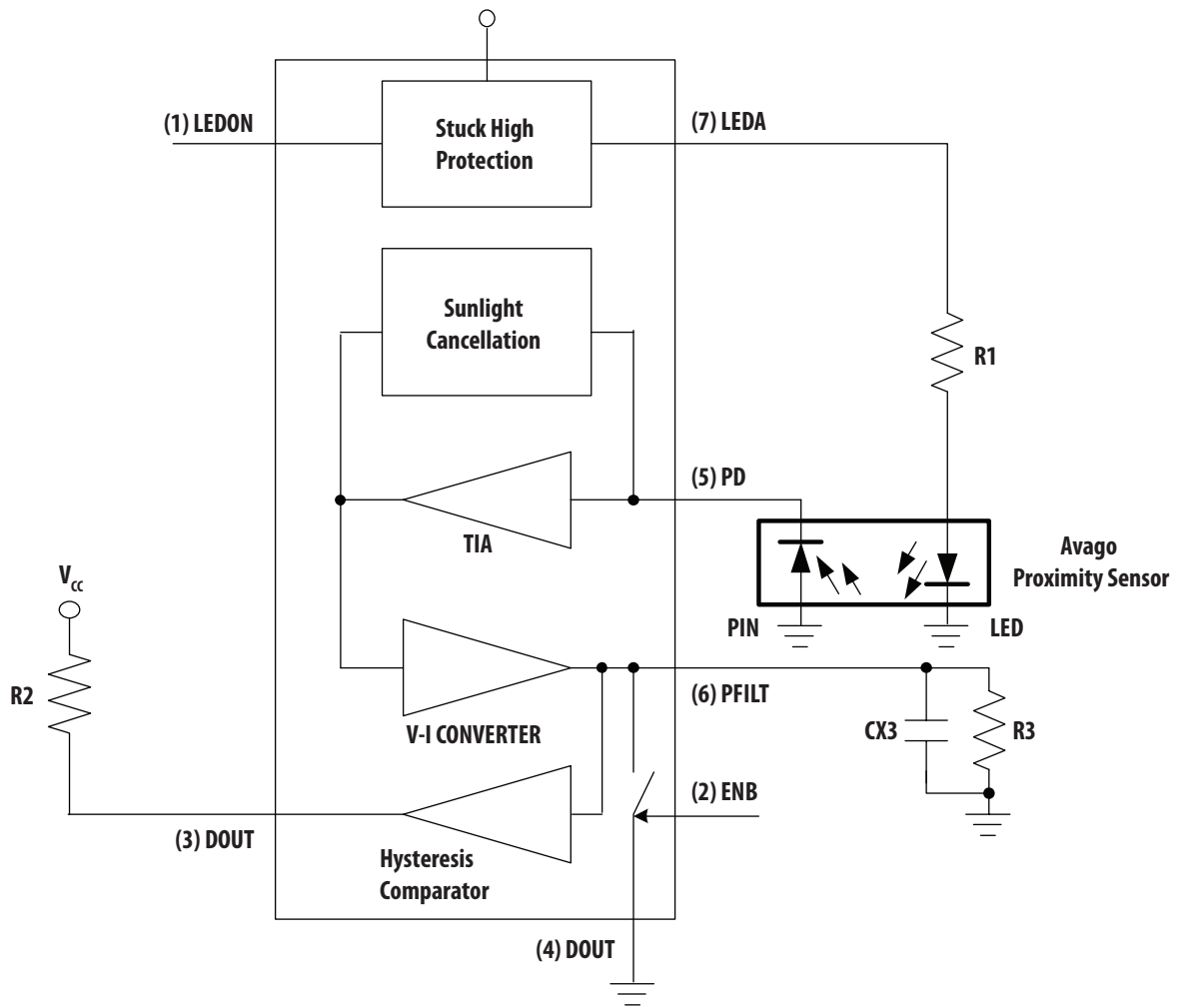
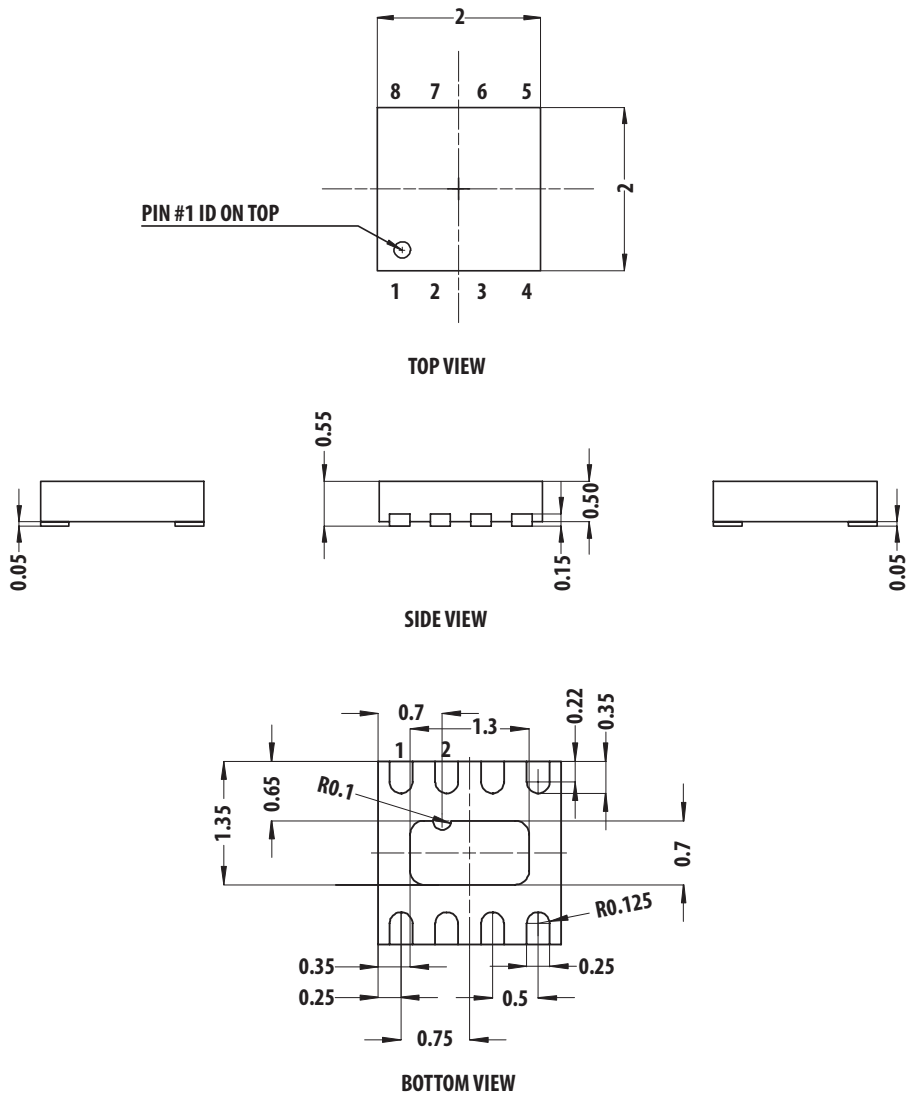

Figure 2. APDS-9700 Block Diagram

# APDS-9700 Package Dimensions



Dimensions in mm. Tolerance  $\pm 0.1$ mm

**Figure 3. Package Outline Dimensions and land pattern**

## APDS-9700 Tape and Reel Dimensions

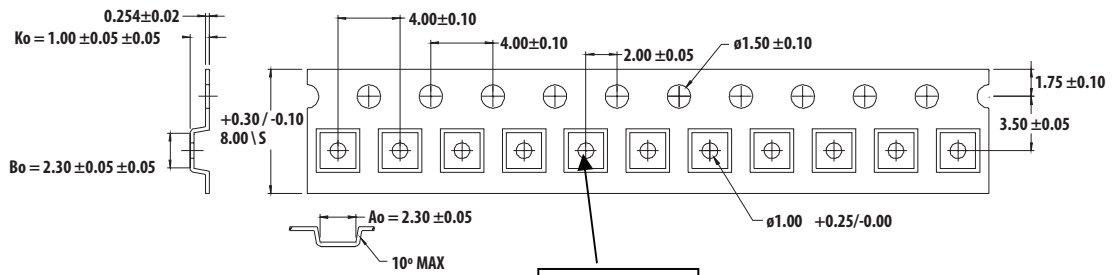

### Unit Orientation Package

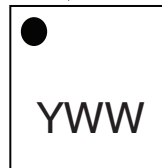
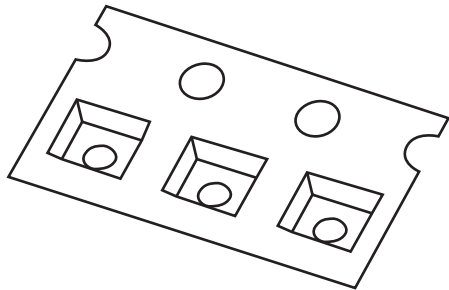

### Note:

1. All unit are in millimeters
2. General Tolerance: Specified
3. Resistivity: <10
4. Material: Polycarbonate

Figure 4. APDS-9700 Tape and Reel Dimensions

### Marking Information

The unit is marked 'YWW' on the chip.

Y = Year

WW= work week

# Reel Drawings

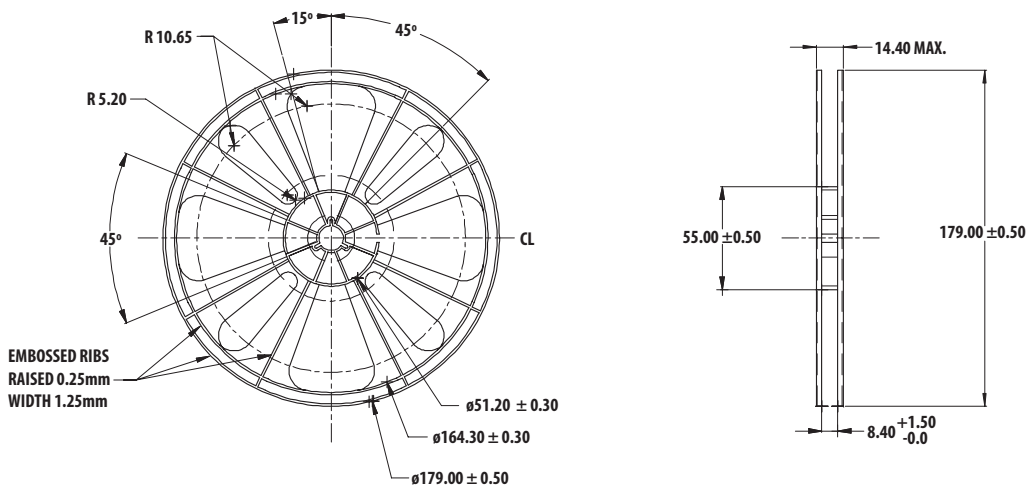
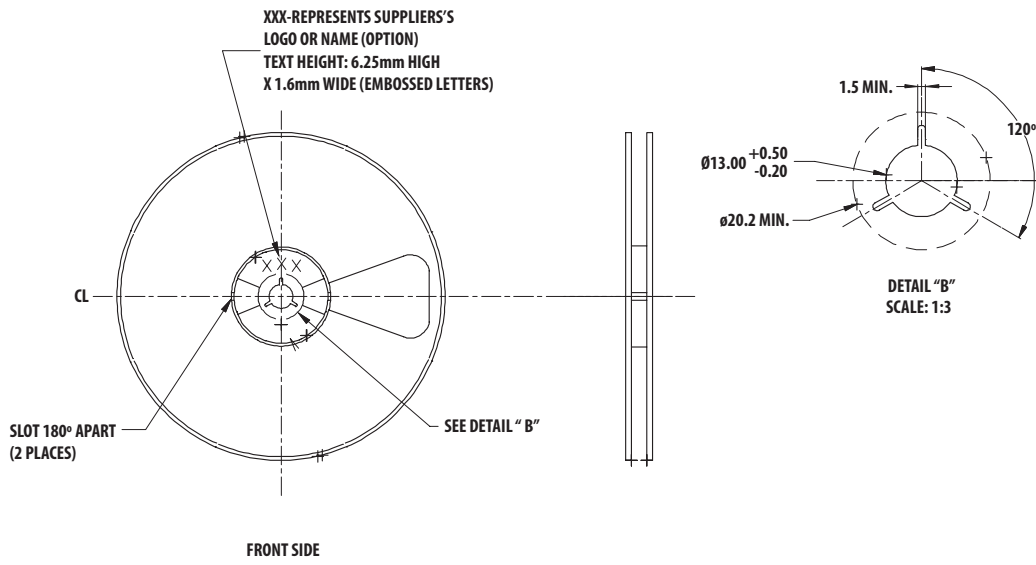



## APDS-9700 Moisture Proof Packaging

All APDS-9700 options are shipped in moisture proof package.

This part is compliant to JEDEC Level 1.

### Recommended Storage Conditions

Storage Temperature	The units in tape and reel are recommended to be kept in a controlled climate environment, with temp at 25 +/-10°C and relative humidity at 55 +/-15%.
Time from unsealing to soldering	This part is compliant to JEDEC MSL-1 (unlimited floor life at < 30°C / 85%RH)

### Recommended Reflow Profile

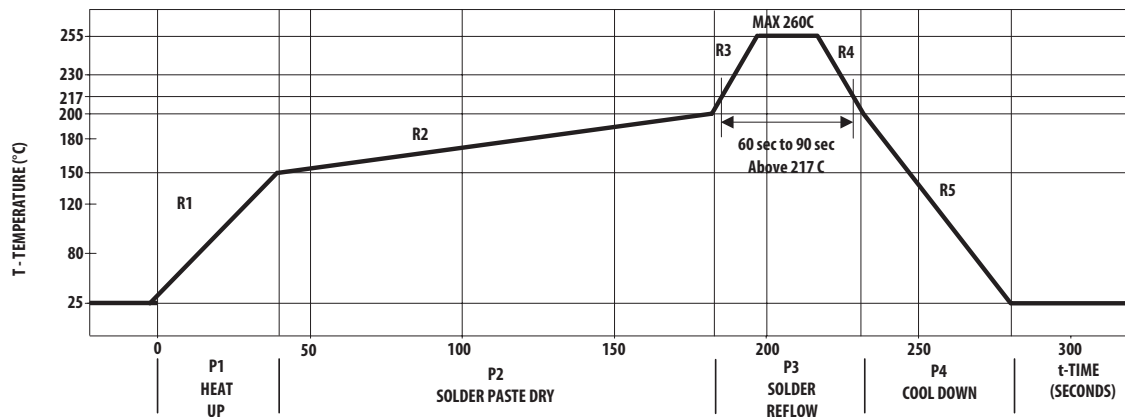

The reflow profile is a straight-line representation of a nominal temperature profile for a convective reflow solder process. The temperature profile is divided into four process zones, each with different  $\Delta T/\Delta \text{time}$  temperature change rates or duration. The  $\Delta T/\Delta \text{time}$  rates or duration are detailed in the above table. The temperatures are measured at the component to printed circuit board connections.

In process zone P1, the PC board and APDS-9700 pins are heated to a temperature of 150°C to activate the flux in the solder paste. The temperature ramp up rate, R1, is limited to 3°C per second to allow for even heating of both the PC board and APDS-9700 pins.

Process zone P2 should be of sufficient time duration (100 to 180 seconds) to dry the solder paste. The temperature is raised to a level just below the liquidus point of the solder, usually 200°C (392°F).

Process zone P3 is the solder reflow zone. In zone P3, the temperature is quickly raised above the liquidus point of solder to 255°C (491°F) for optimum results. The dwell time above the liquidus point of solder should be between 20 and 40 seconds. It usually takes about 20 seconds to assure proper coalescing of the solder balls into liquid solder and the formation of good solder connections. Beyond a dwell time of 40 seconds, the intermetallic growth within the solder connections becomes excessive, resulting in the formation of weak and unreliable connections. The temperature is then rapidly reduced to a point below the solidus temperature of the solder, usually 200°C (392°F), to allow the solder within the connections to freeze solid.

Process zone P4 is the cool down after solder freeze. The cool down rate, R5, from the liquidus point of the solder to 25°C (77°F) should not exceed 6°C per second maximum. This limitation is necessary to allow the PC board and APDS-9700 pins to change dimensions evenly, putting minimal stresses on the APDS-9700.

It is recommended to perform reflow soldering no more than twice.

# APDS-9700 Typical Timing Waveforms

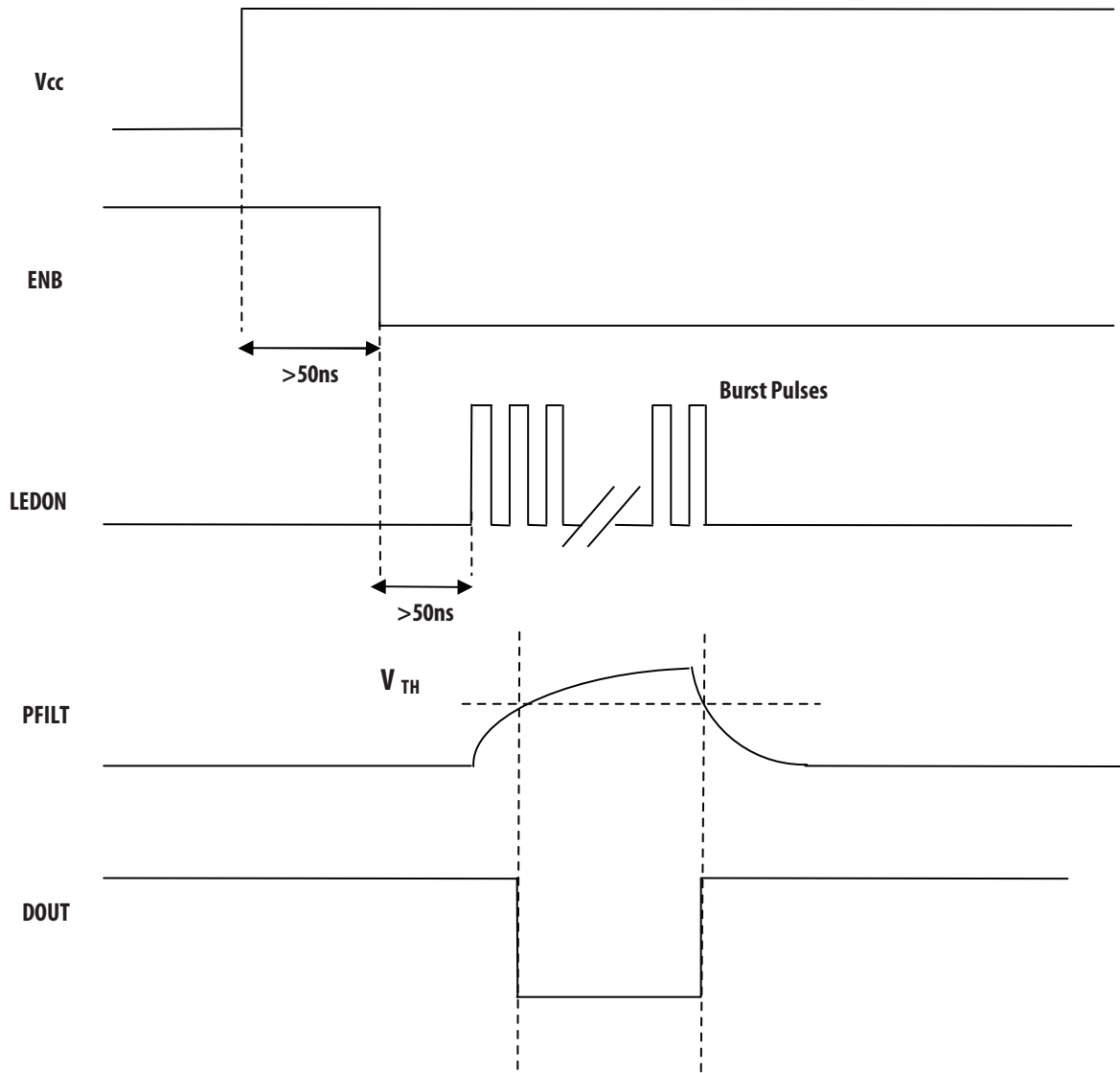

# APDS-9700 Performance Charts (Typical Conditions)

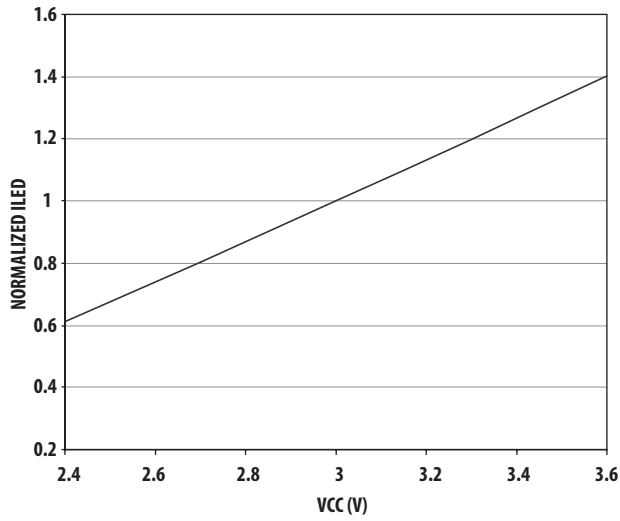

Figure 8. Normalized ILED Vs Vcc (T=25°C, R1=10Ω)

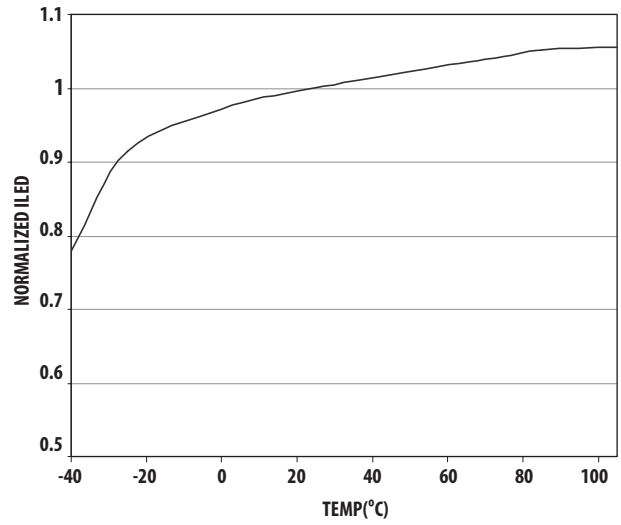

Figure 9. Normalized ILED VS Temp (VCC=3V, R1=10Ω)

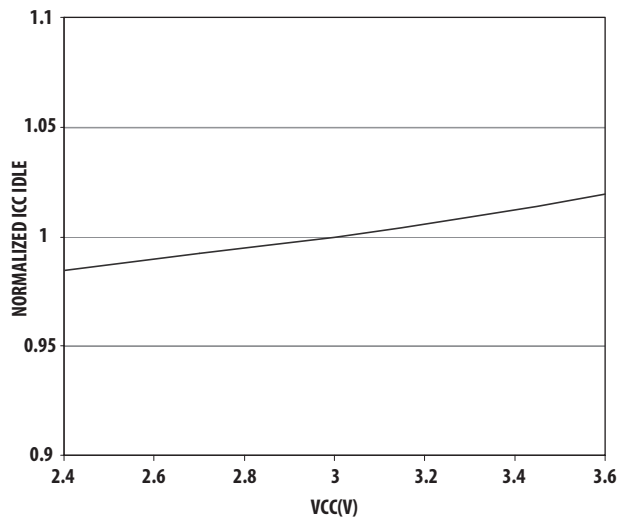

Figure 10. Normalized ICC Idle Vs Vcc (T=25°C)

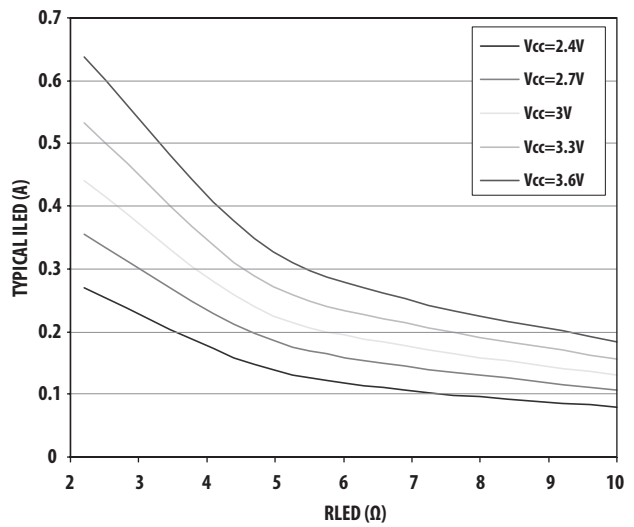

Figure 11. ILED VS RLED (T=25°C)

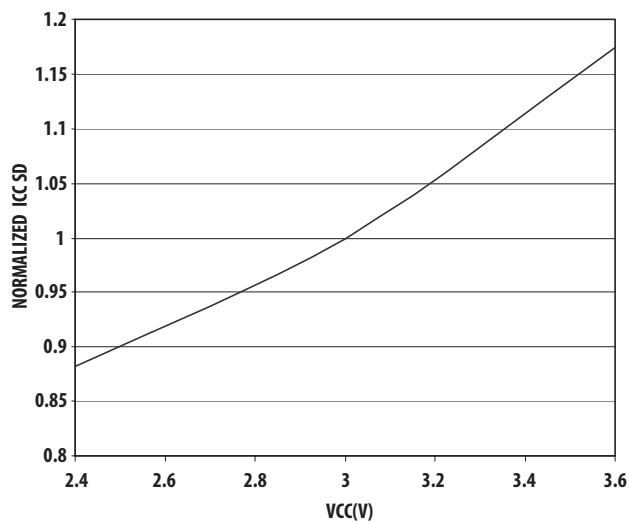

Figure 12. Normalized ICC SD VS VCC (T=25°C)

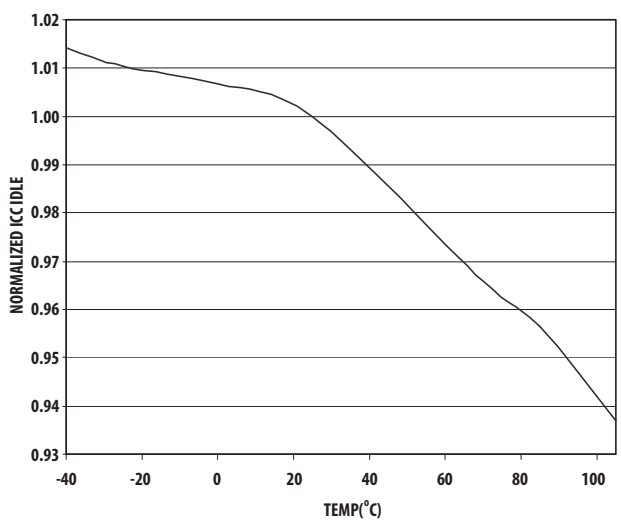
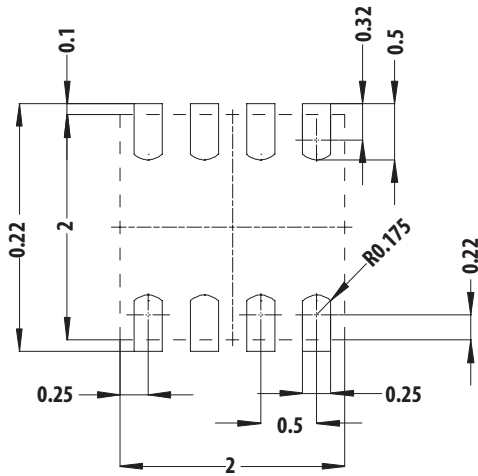

Figure 13. Normalized ICC Idle VS TEMP (VCC=3V)

## Appendix A: SMT Assembly Application Note

### Recommended Minimum Land pattern and Keep-out Area



#### SOLDER LAND PATTERN

Dimension in mm. Tolerances +0.1mm

#### Keep-out Area Recommendations:

1. Area of Solder Land pattern = 2.3mm x 2.1mm
2. Module placement tolerance & keep out on each side with no lead = 0.55mm & keep out on each side solder lead = 0.8mm
3. Keep-out area = 3.9mm x 3.2mm

For product information and a complete list of distributors, please go to our web site: [www.avagotech.com](http://www.avagotech.com)

Avago, Avago Technologies, and the A logo are trademarks of Avago Technologies, Limited in the United States and other countries. Data subject to change. Copyright © 2007 Avago Technologies Limited. All rights reserved. AV02-0893EN - January 4, 2008

**AVAGO**  
TECHNOLOGIES