

FEATURES

- 60 MSPS Sampling Rate
- 9.3 Effective Number of Bits at $f_{IN} = 10.3$ MHz
- 250 mW Total Power at 60 MSPS
- Selectable Input Bandwidth of 50 MHz or 130 MHz
- On-Chip T/H and Voltage Reference
- Single 5 V Supply Voltage
- 5 V or 3 V Logic I/O Compatible
- Input Range and Output Coding Options Available

APPLICATIONS

- Medical Imaging
- Digital Communications
- Professional Video
- Instrumentation
- Set-Top Box

GENERAL DESCRIPTION

The AD9051 is a complete 10-bit monolithic sampling analog-to-digital converter (ADC) with an onboard track-and-hold and reference. The unit is designed for low cost, high performance applications and requires only 5 V and an encode clock to achieve 60 MSPS sample rates with 10-bit resolution.

The encode clock is TTL compatible and the digital outputs are CMOS; both can operate with 5 V/3 V logic. The two-step architecture used in the AD9051 is optimized to provide the best dynamic performance available while maintaining low power consumption.

FUNCTIONAL BLOCK DIAGRAM

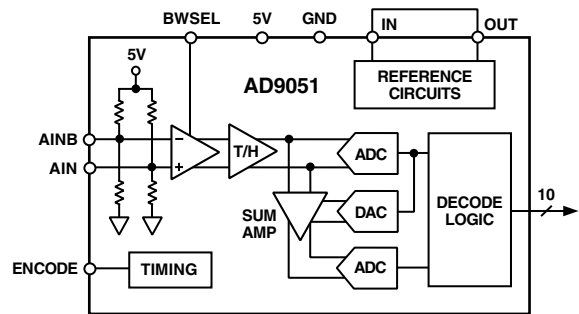

A 2.5 V reference is included onboard, or the user can provide an external reference voltage for gain control or matching of multiple devices. Fabricated on a state-of-the-art BiCMOS process, the AD9051 is packaged in a space saving surface mount package (SSOP) and is specified over the industrial temperature range (-40°C to $+85^{\circ}\text{C}$).

REV. B

Information furnished by Analog Devices is believed to be accurate and reliable. However, no responsibility is assumed by Analog Devices for its use, nor for any infringements of patents or other rights of third parties that may result from its use. No license is granted by implication or otherwise under any patent or patent rights of Analog Devices.

AD9051—SPECIFICATIONS ($V_D = 5\text{ V}$, $V_{DD} = 3\text{ V}$; external reference = 2.50 V; ENCODE = 60 MSPS unless otherwise noted)

Parameter	Temp	Test Level	AD9051BRS			AD9051BRS-2V			Unit
			Min	Typ	Max	Min	Typ	Max	
RESOLUTION			10			10			Bits
DC ACCURACY									
Differential Nonlinearity	25°C	I		0.75	1.50		0.75	1.50	LSB
	Full	V		0.90			0.90		LSB
Integral Nonlinearity	25°C	I		0.75	1.50		0.75	1.50	LSB
	Full	V		0.90			0.90		LSB
No Missing Codes	25°C	I	GUARANTEED			GUARANTEED			
Gain Error ¹	25°C	I		±0.3	±2.5		±0.3	±3.0	% FS
	Full	VI			±5.0			±5.5	% FS
Gain Tempco ¹	Full	V		±10			±10		ppm/°C
ANALOG INPUT									
Input Voltage Range ²	25°C	V		1.25			2.0		V p-p
Input Offset Voltage	25°C	I	-14	+5.0	+26	-14	+5.0	+26	LSB
Input Resistance	25°C	I	4.0	6.0		4.0	6.0		kΩ
Input Capacitance	25°C	V		5			5		pF
Analog Bandwidth (BW SEL +V _D /NC) ³	25°C	V		50/130			50/130		MHz
BANDGAP REFERENCE									
Output Voltage (I _O @ 200 μA)	Full	VI	2.4	2.5	2.6	2.4	2.5	2.6	V
Temperature Coefficient	Full	V		±33			±33		ppm/°C
Power Supply Sensitivity	Full	V		6.2			6.2		mV/V
Reference Input Current (V _{IN} = 2.50 V)	Full	VI		2.0	25		2.0	25	μA
SWITCHING PERFORMANCE									
Maximum Conversion Rate	Full	VI	60			60			MSPS
Minimum Conversion Rate ⁴	Full	IV		2.0	5.0		2.0	5.0	MSPS
Aperture Delay (t _A)	25°C	V		2.5			2.5		ns
Aperture Uncertainty (Jitter)	25°C	V		5			5		ps, rms
Output Valid Time (t _V) ⁵	Full	VI	4.0			4.0			ns
Output Propagation Delay (t _{PD}) ⁵	Full	VI		5.5	10		5.5	10	ns
DYNAMIC PERFORMANCE⁶									
Transient Response	25°C	V		10			10		ns
Overshoot Recovery Time	25°C	V		10			10		ns
ENOBs									
f _{IN} = 1.20 MHz	25°C	V		9.6			9.6		ENOB
f _{IN} = 10.3 MHz	25°C	I	8.93	9.3		8.93	9.3		ENOB
f _{IN} = 29.0 MHz	25°C	V		9.1			9.1		ENOB
Signal-to-Noise Ratio (SINAD)									
f _{IN} = 1.20 MHz	25°C	V		58.5			57.5		dB
f _{IN} = 10.3 MHz	25°C	I	55	57		54	56		dB
f _{IN} = 29.0 MHz	25°C	V		55			54		dB
Signal-to-Noise Ratio (Without Harmonics)									
f _{IN} = 1.20 MHz	25°C	V		59			59		dB
f _{IN} = 10.3 MHz	25°C	I	56	58		56	58		dB
f _{IN} = 29.0 MHz	25°C	V		56.5			56.5		dB
2nd Harmonic Distortion									
f _{IN} = 1.20 MHz	25°C	V		-74			-68		dBc
f _{IN} = 10.3 MHz	25°C	I		-73	-60		-64	-58	dBc
f _{IN} = 29.0 MHz	25°C	V		-67			-60		dBc
3rd Harmonic Distortion									
f _{IN} = 1.20 MHz	25°C	V		-74			-69		dBc
f _{IN} = 10.3 MHz	25°C	I		-70	-60		-65	-60	dBc
f _{IN} = 29.0 MHz	25°C	V		-65			-60		dBc
Two-Tone Intermodulation									
Distortion (IMD)	25°C	V		-65			-65		dBc
Differential Phase	25°C	V		0.1			0.1		Degrees
Differential Gain	25°C	V		0.5			0.5		%

Parameter	Temp	Test Level	AD9051BRS			AD9051BRS-2V			Unit
			Min	Typ	Max	Min	Typ	Max	
ENCODE INPUT									
Logic "1" Voltage	Full	VI	2.0			2.0			V
Logic "0" Voltage	Full	VI			0.8			0.8	V
Logic "1" Current	Full	VI			1			1	μA
Logic "0" Current	Full	VI			1			1	μA
Input Capacitance	25°C	V		7.5			7.5		pF
Encode Pulsewidth High (t_{EH})	25°C	IV	7.5			7.5			ns
Encode Pulsewidth Low (t_{EL})	25°C	IV	7.5			7.5			ns
DIGITAL OUTPUTS									
Logic "1" Voltage (5.0 V_{DD})	Full	VI	4.95			4.95			V
Logic "0" Voltage (5.0 V_{DD})	Full	VI			0.05			0.05	V
Logic "1" Voltage (3.0 V_{DD})	Full	VI	2.95			2.95			V
Logic "0" Voltage (3.0 V_{DD})	Full	VI			0.05			0.05	V
Output Coding ⁷			Offset Binary			Offset Binary			
POWER SUPPLY									
V_D , V_{DD} Supply Current	Full	VI		50	63		50	63	mA
Power Dissipation ⁸	Full	VI		250	315		250	315	mW
Power Supply Rejection Ratio (PSRR) ⁹	25°C	I		±2	±10		±7	±15	mV/V

NOTES

¹Gain error and gain temperature coefficient are based on the ADC only (with a fixed 2.5 V external reference).

²Contact factory or authorized sales agent for information concerning the availability of expanded input voltage range devices.

³3 dB bandwidth with full-power input signal.

⁴Minimum conversion rate at which all data sheet specifications remain stable.

⁵ t_V and t_{PD} are measured from the threshold crossing of the ENCODE input to valid TTL levels 0.5 V and 2.4 V of the digital outputs with $V_{DD} = 3.0$ V. The output ac load during test is 5 pF.

⁶SNR/harmonics tested with an analog input voltage of -0.5 dBFS. All tests performed at 60 MSPS.

⁷Contact factory or authorized sales agent for information concerning the availability of alternative output coding and input range devices.

⁸Power dissipation is measured under the following conditions: analog input = -FS at 60 MSPS ENCODE.

⁹A change in input offset voltage with respect to a change in V_D .

Specifications subject to change without notice.

AD9051

ABSOLUTE MAXIMUM RATINGS*

V_D, V_{DD}	7 V
Analog Inputs	-0.5 V to $V_D + 0.5$ V
Digital Inputs	-0.5 V to V_D
VREF Input	-0.5 V to V_D
Digital Output Current	20 mA
Operating Temperature	-55°C to +125°C
Storage Temperature	-65°C to +150°C
Maximum Junction Temperature	150°C
Maximum Case Temperature	150°C

*Stresses above those listed under Absolute Maximum Ratings may cause permanent damage to the device. This is a stress rating only; functional operation of the device at these or any other conditions above those indicated in the operational sections of this specification is not implied. Exposure to absolute maximum ratings for extended periods may effect device reliability.

EXPLANATION OF TEST LEVELS

Test Level

- I. 100% production tested.
- II. 100% production tested at 25°C and sample tested at specified temperatures.
- III. Sample tested only.
- IV. Parameter is guaranteed by design and characterization testing.
- V. Parameter is a typical value only.
- VI. 100% production tested at 25°C; guaranteed by design and characterization testing for industrial temperature range.

ORDERING GUIDE

Model	Temperature Range	Package Description	Package Options
AD9051BRS	-40°C to +85°C	28-Lead Shrink Small Outline Package (SSOP)	RS-28
AD9051BRS-2V	-40°C to +85°C	28-Lead Shrink Small Outline Package (SSOP)	RS-28
AD9051/PCB	25°C		Evaluation Board
AD9051-2V/PCB	25°C		Evaluation Board

Table I. Digital Coding (Single-Ended Input with AIN, AINB Bypassed to GND)

Analog Input	Voltage Level	OR (Out of Range)	Digital Output MSB . . . LSB
3.126 (3.50)*	Positive Full Scale + 1 LSB	1	1111111111
2.5	Midscale	0	0111111111
1.874 (1.50)*	Negative Full Scale - 1 LSB	1	0000000000

*(BRS-2V Version)

CAUTION

ESD (electrostatic discharge) sensitive device. Electrostatic charges as high as 4000 V readily accumulate on the human body and test equipment and can discharge without detection. Although the AD9051 features proprietary ESD protection circuitry, permanent damage may occur on devices subjected to high-energy electrostatic discharges. Therefore, proper ESD precautions are recommended to avoid performance degradation or loss of functionality.



PIN FUNCTION DESCRIPTIONS

Pin No.	Mnemonic	Description
1, 6, 7, 12, 21, 23	GND	Ground
2, 8, 11	V _D	Analog 5 V Power Supply
3	VREFOUT	Internal Bandgap Voltage Reference (Nominally 2.5 V)
4	VREFIN	Input to Reference Amplifier. Voltage reference for ADC is connected here.
5	BWSEL	Bandwidth Select. NC = 130 MHz nominal. +V _D = 50 MHz nominal.
9	AINB	Complementary Analog Input Pin (Analog Input Bar)
10	AIN	Analog Input Pin
13	ENCODE	Encode Clock Input to ADC. Internal T/H is placed in hold mode (ADC is encoding) on rising edge of encode signal.
14	OR	Out of Range Signal. Logic "0" when analog input is in nominal range. Logic "1" when analog input is out of nominal range.
15	D9 (MSB)	Most Significant Bit of ADC Output
16–19	D8–D5	Digital Output Bits of ADC
20, 22	V _{DD}	Digital Output Power Supply (Only Used by Digital Outputs)
24–27	D4–D1	Digital Output Bits of ADC
28	D0 (LSB)	Least Significant Bit of ADC Output

PIN CONFIGURATION

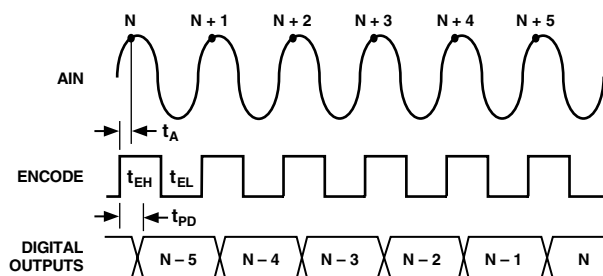
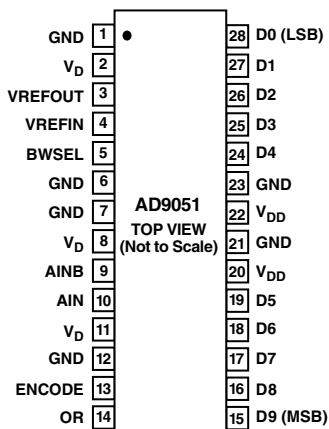

Figure 1. Timing Diagram

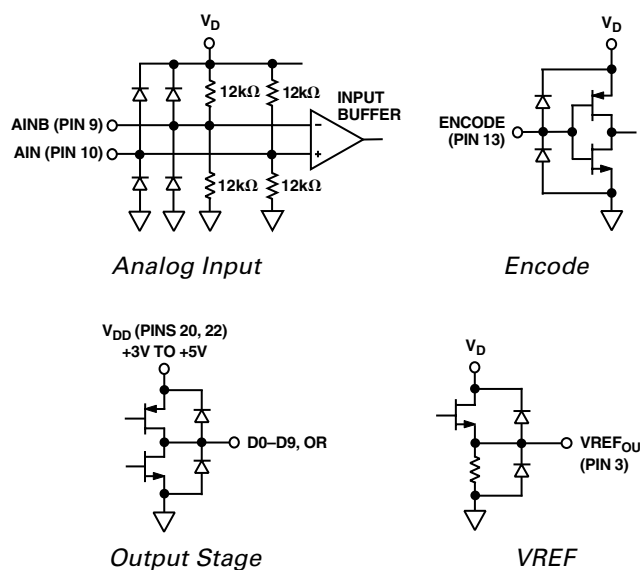
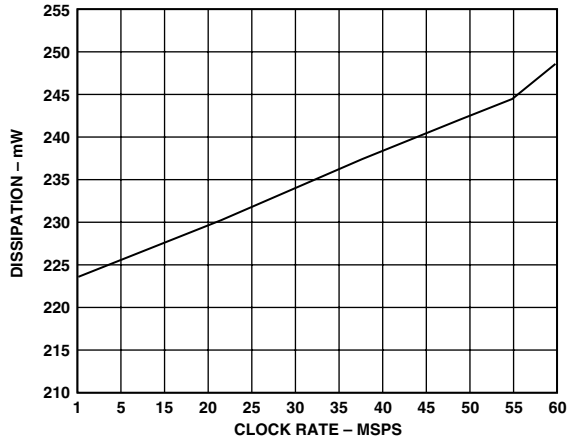
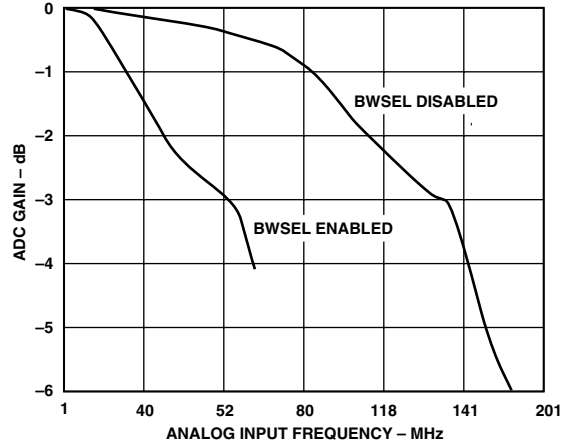

Figure 2. Equivalent Circuits

AD9051



TPC 1. Power Dissipation vs. Clock Rate



TPC 4. ADC Gain vs. AIN Frequency

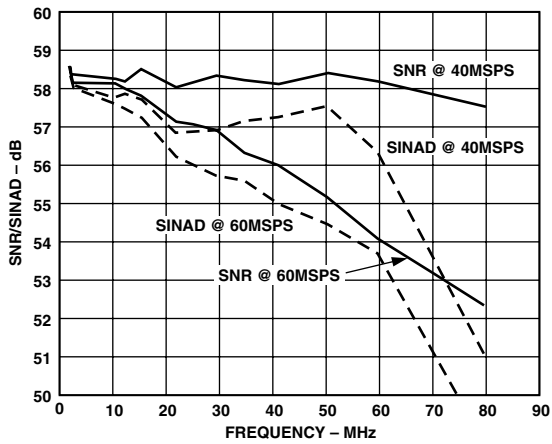

TPC 2. SNR/SINAD vs. AIN Frequency

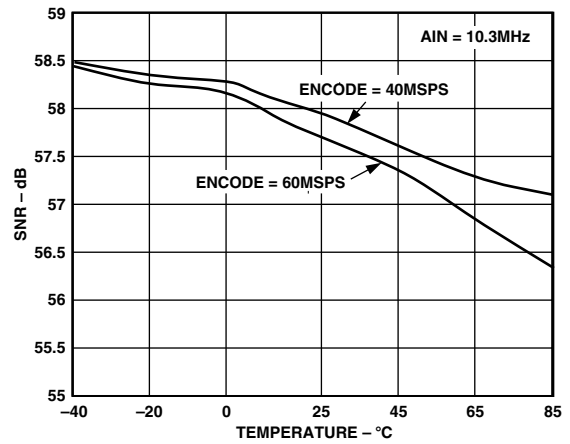

TPC 5. SNR vs. Temperature

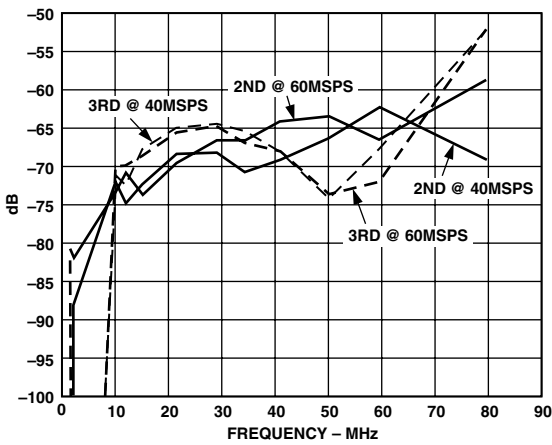

TPC 3. Harmonics vs. AIN Frequency

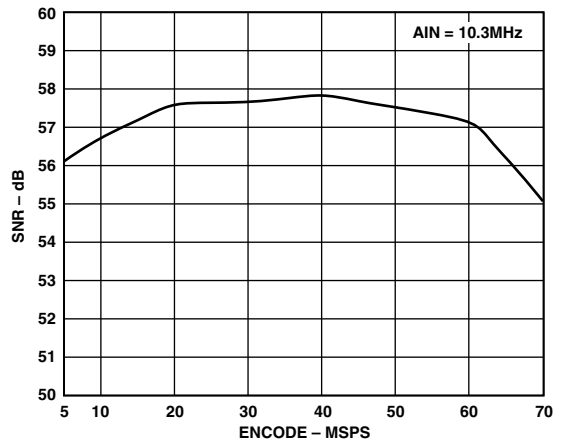

TPC 6. SNR vs. Clock Rate

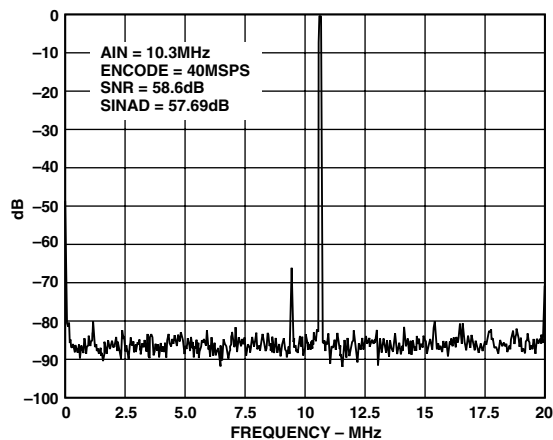

TPC 7. FFT Plot 40 MSPS, 10.3 MHz

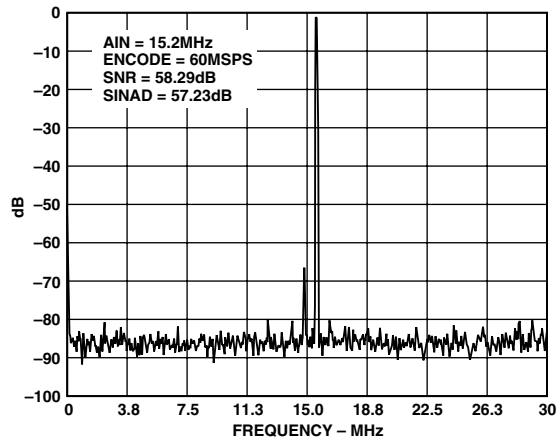

TPC 10. FFT Plot 60 MSPS, 15.2 MHz

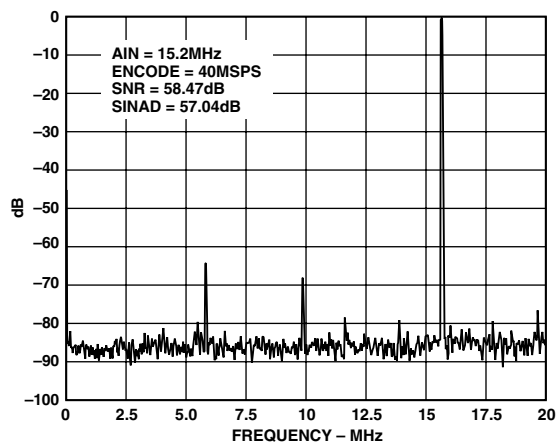

TPC 8. FFT Plot 40 MSPS, 15.2 MHz

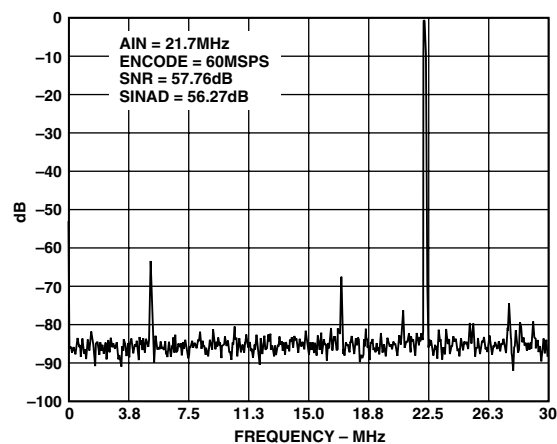

TPC 11. FFT Plot 60 MSPS, 21.7 MHz

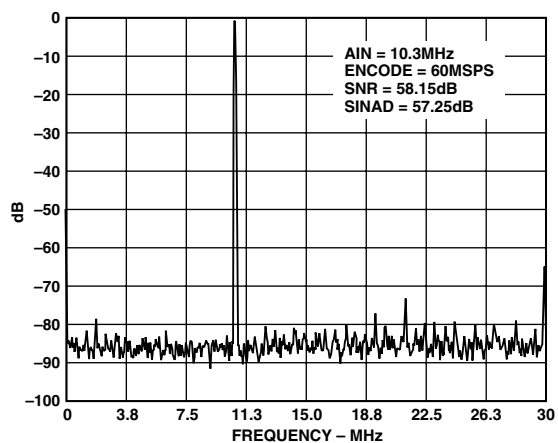

TPC 9. FFT Plot 60 MSPS, 10.3 MHz

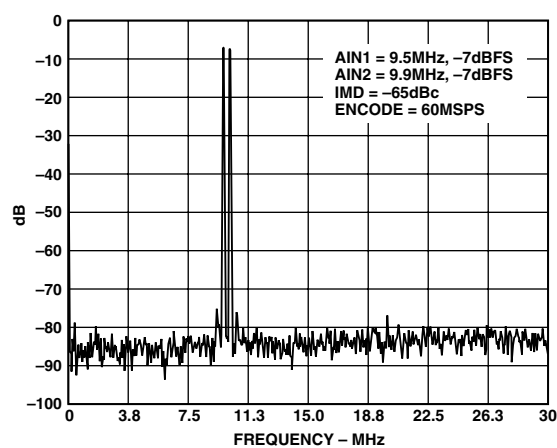

TPC 12. Two-Tone IMD

AD9051

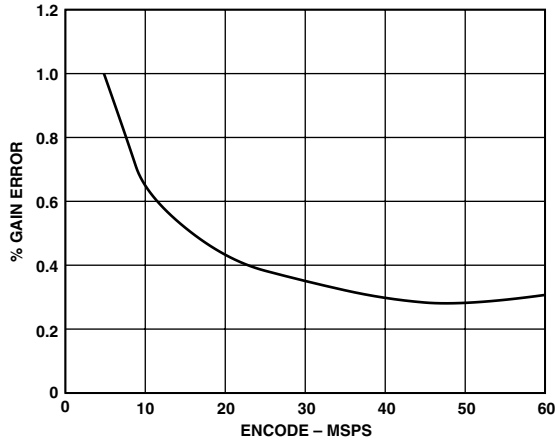

TPC 13. Gain vs. Clock Rate

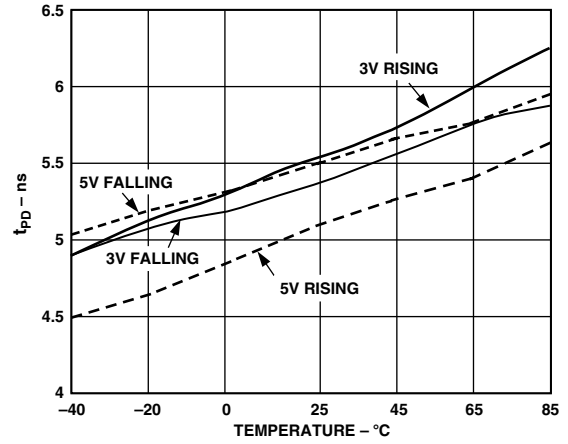

TPC 16. t_{PD} vs. Temperature 3 V/5 V

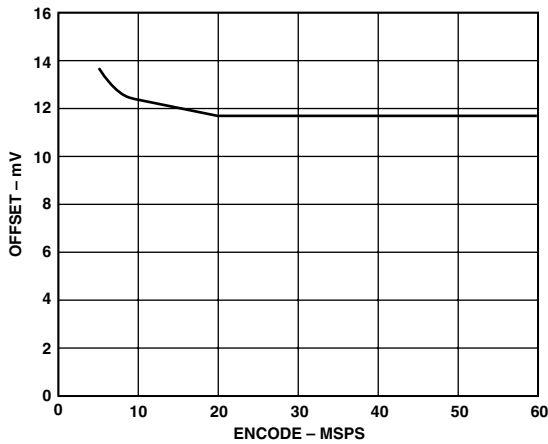

TPC 14. Offset vs. Clock Rate

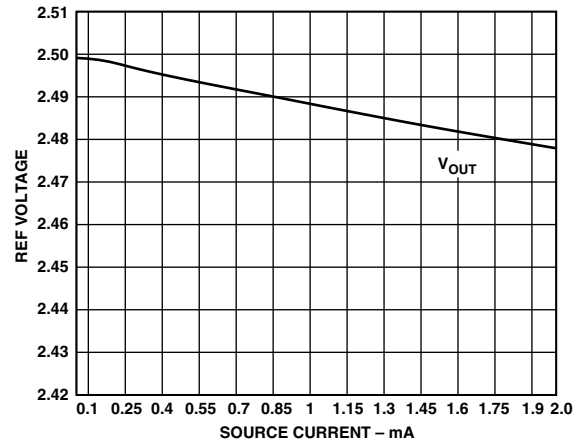

TPC 17. Reference Load Regulation

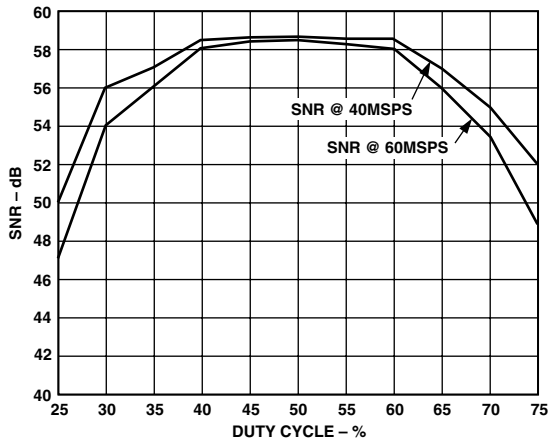

TPC 15. SNR vs. Duty Cycle

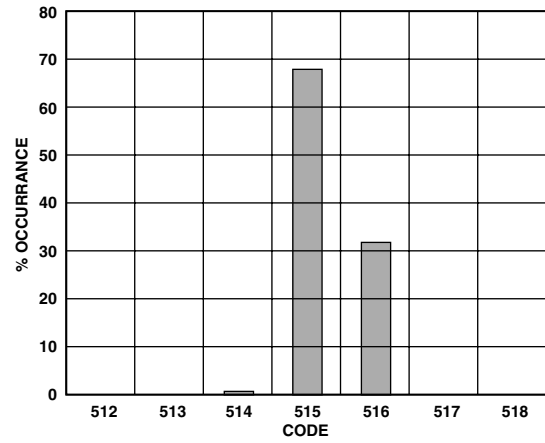

TPC 18. Midscale Histogram (Inputs Tied)

THEORY OF OPERATION

Refer to the block diagram on the front page.

The AD9051 employs a subranging architecture with digital error correction. This combination of design techniques ensures true 10-bit accuracy at the digital outputs of the converter.

At the input, the analog signal is buffered by a high speed differential buffer and applied to a track-and-hold (T/H) that holds the analog value present when the unit is strobed with an ENCODE command. The conversion process begins on the rising edge of this pulse. The two stage architecture completes a coarse and then a fine conversion of the T/H output signal.

Error correction and decode logic correct and align data from the two conversions and present the result as a 10-bit parallel digital word. Output data are strobed on the rising edge of the ENCODE command. The subranging architecture results in five pipeline delays for the output data. Refer to the AD9051 Timing Diagram.

USING THE AD9051

3 V System

The digital input and outputs of the AD9051 can be easily configured to directly interface to 3 V logic systems. The encode input (Pin 13) is TTL compatible with a logic threshold of 1.5 V. This input is actually a CMOS stage (refer to Equivalent Encode Input Stage) with a TTL threshold, allowing operation with TTL, CMOS and 3 V CMOS logic families. Using 3 V CMOS logic allows the user to drive the encode directly without the need to translate to 5 V. This saves the user power and board space. As with all high speed data converters, the clock signal must be clean and jitter free to prevent the degradation of dynamic performance.

The AD9051 outputs can also directly interface to 3 V logic systems. The digital outputs are standard CMOS stages (refer to AD9051 Output Stage) with isolated supply pins (Pins 20, 22 V_{DD}). By varying the voltage on the V_{DD} pins, the digital output levels vary respectively. By connecting Pins 20 and 22 to the 3 V logic supply, the AD9051 will supply 3 V output levels. Care should be taken to filter and isolate the output supply of the AD9051 as noise could be coupled into the ADC, limiting performance.

Analog Input

The analog input of the AD9051 is a differential input buffer (refer to AD9051 Equivalent Analog Input). The differential inputs are internally biased at 2.5 V, obviating the need for external biasing. Excellent performance is achieved whether the analog inputs are driven single-endedly or differentially (for best dynamic performance, impedances at AIN and AINB should match).

Figure 3 shows typical connections for the analog inputs when using the AD9051 in a dc-coupled system with single-ended signals. All components are powered from a single 5 V supply. The AD820 is used to offset the ground referenced input signal to the level required by the AD9051.

AC coupling of the analog inputs of the AD9051 is easily accomplished. Figure 4 shows capacitive coupling of a single-ended signal while Figure 5 shows transformer coupling differentially into the AD9051.

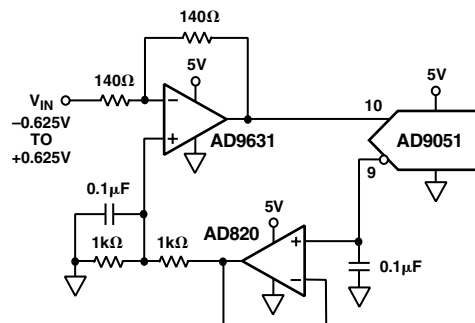

Figure 3. Single Supply, Single-Ended, DC-Coupled AD9051

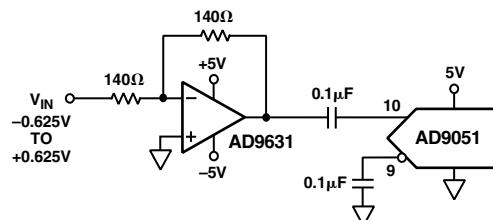

Figure 4. Single-Ended, Capacitively-Coupled AD9051

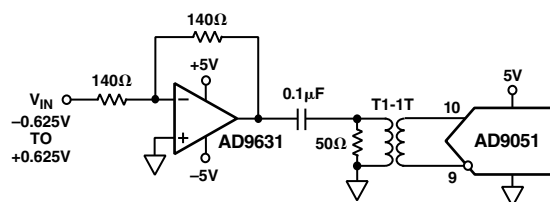

Figure 5. Differentially Driven AD9051 Using Transformer Coupling

The AD830 provides a unique method of providing dc level shift for the analog input. Using the AD830 allows a great deal of flexibility for adjusting offset and gain. Figure 6 shows the AD830 configured to drive the AD9051. The offset is provided by the internal biasing of the AD9051 differential input (Pin 9). For more information regarding the AD830, see the AD830 data sheet.

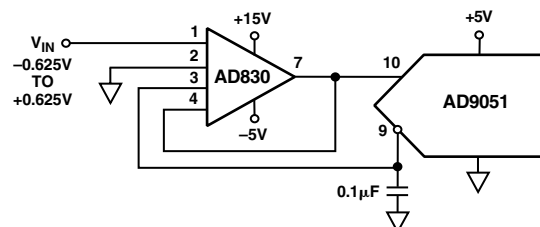

Figure 6. Level-Shifting with the AD830

AD9051

Overdrive of the Analog Input

Special care was taken in the design of the analog input section of the AD9051 to prevent damage and corruption of data when the input is overdriven. The nominal input range is 1.875 V to 3.125 V (1.25 V p-p centered at 2.5 V). Out-of-range comparators detect when the analog input signal is out of this range and the input buffer is clamped. The digital outputs are locked at their maximum or minimum value (i.e., all “0” or all “1”). This precludes the digital outputs changing to an invalid value when the analog input is out of range.

The input is protected to one volt outside the power supply rails. For nominal power (5 V and ground), the analog input will not be damaged with signals from +5.5 V to -0.5 V.

Timing

The performance of the AD9051 is very insensitive to the duty cycle of the clock. Pulsewidth variations of as much as $\pm 15\%$ for encode rates of 40 MSPS and $\pm 10\%$ for encode rates of 60 MSPS will cause no degradation in performance. (See Figure 17, SNR vs. Duty Cycle.)

The AD9051 provides latched data outputs, with five pipeline delays. Data outputs are available one propagation delay (t_{PD}) after the rising edge of the encode command (refer to Figure 1, Timing Diagram). The length of the output data lines and loads placed on them should be minimized to reduce transients within the AD9051; these transients can detract from the converter's dynamic performance.

Power Dissipation

The power dissipation specification in the parameter table is measured under the following conditions: encode is 60 MSPS, analog input is -FS.

As shown in Figure 3, the actual power dissipation varies based on these conditions. For instance, reducing the clock rate will reduce power as expected for CMOS-type devices. The loading determines the power dissipated in the output stages.

The analog input frequency and amplitude in conjunction with the clock rate determine the switching rate of the output data bits. Power dissipation increases as more data bits switch at faster rates. For instance, if the input is a dc signal that is out of range, no output bits will switch. This minimizes power in the output stages, but is not realistic from a usage standpoint.

The dissipation in the output stages can be minimized by interfacing the outputs to 3 V logic (refer to Using the AD9051, 3 V System). The lower output swings minimize power consumption as follows: $(1/2 C_{LOAD} \times V_{DD}^2 \times \text{Update Rate})$.

Voltage Reference

A stable and accurate 2.5 V voltage reference is built into the AD9051 (Pin 3, VREFOUT). In normal operation the internal reference is used by strapping together Pins 3 and 4 of the AD9051. The internal reference has 500 μA of extra drive current that can be used for other circuits.

Some applications may require greater accuracy, improved temperature performance, or adjustment of the gain of the AD9051, which cannot be obtained by using the internal reference. For these applications, an external 2.5 V reference can be used to connect to Pin 4 of the AD9051. The VREFIN requires 2 μA of drive current.

The input range can be adjusted by varying the reference voltage applied to the AD9051. No appreciable degradation in performance occurs when the reference is adjusted $\pm 5\%$. The full-scale range of the ADC tracks reference voltage changes linearly.

EVALUATION BOARD

The AD9051 evaluation board is a convenient and easy way to evaluate the performance of the AD9051.

Analog Input

The evaluation board requires a 1.25 V p-p input. The signal is buffered by an AD9631 op amp in the unity gain configuration. The signal is then ac coupled before entering the AD9051 where a dc offset is internally generated. Leave E3 unconnected to E4 for usage with the AD9631. To evaluate performance without this buffer, remove the AD9631 and connect E3 to E4. Keep E1 connected to E2 for use in the low bandwidth mode (50 MHz). Removing this connector will enable high bandwidth mode (130 MHz). Low bandwidth is the recommended mode of operation in order to minimize any high frequency noise coupling into the input of the AD9051.

Encode

The evaluation board is driven with a TTL or CMOS clock into a clock buffer of ac type CMOS logic. This buffer will drive the encode to the AD9051, the data latches, and a “data ready.”

Data Out

The digital data is captured by a pair 74ACQ574 latches. Any unused connector pins should be grounded to the device that is capturing data from the evaluation board. This minimizes any grounding loops that may degrade performance. A separate power plane is provided for supplying the latches, clock buffer, and digital outputs of the AD9051. This supply can be 3 V or 5 V.

Layout

The AD9051 is not layout sensitive if some important guidelines are met. The evaluation board layout provides an example where these guidelines have been followed to optimize performance.

- Provide a solid ground plane connecting both analog and digital sections. Cuts in this plane near the AD9051 should be kept to a minimum.
- Excellent bypassing is essential. All capacitors should be placed as close as possible to the AD9051. No vias should be used to connect capacitors to the AD9051 as this may create a parasitic inductance that can reduce bypassing effectiveness.

The AD9051 evaluation board is provided as a design example for customers of Analog Devices. ADI makes no warranties express, statutory, or implied regarding merchantability of fitness for a particular purpose.

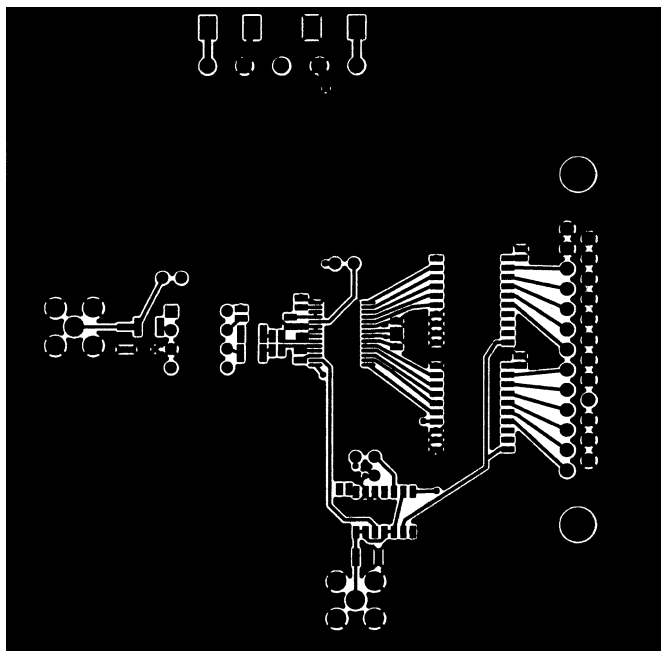

Figure 7. Evaluation Board Top Layer

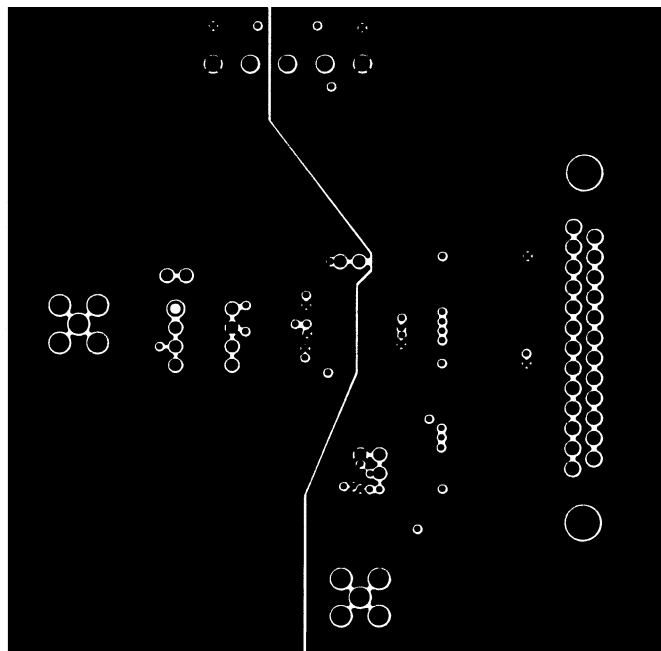

Figure 9. Evaluation Board Bottom Layer

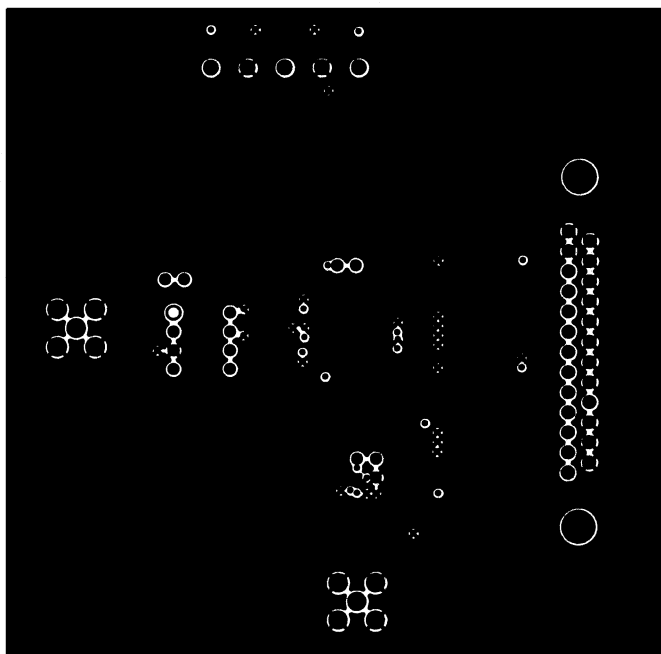

Figure 8. Evaluation Board Ground Layer

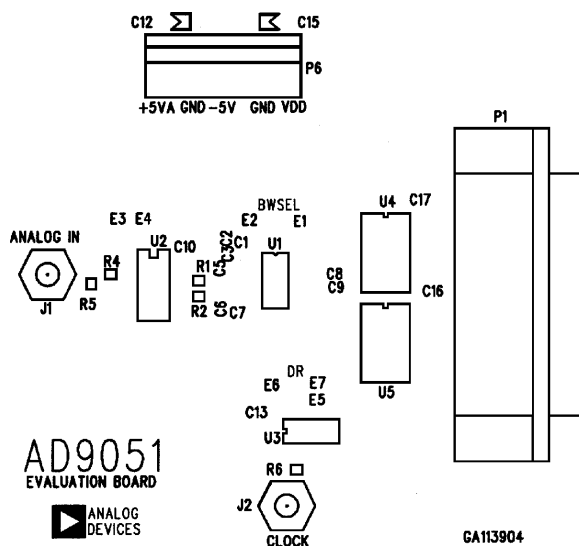

Figure 10. Silkscreen

AD9051

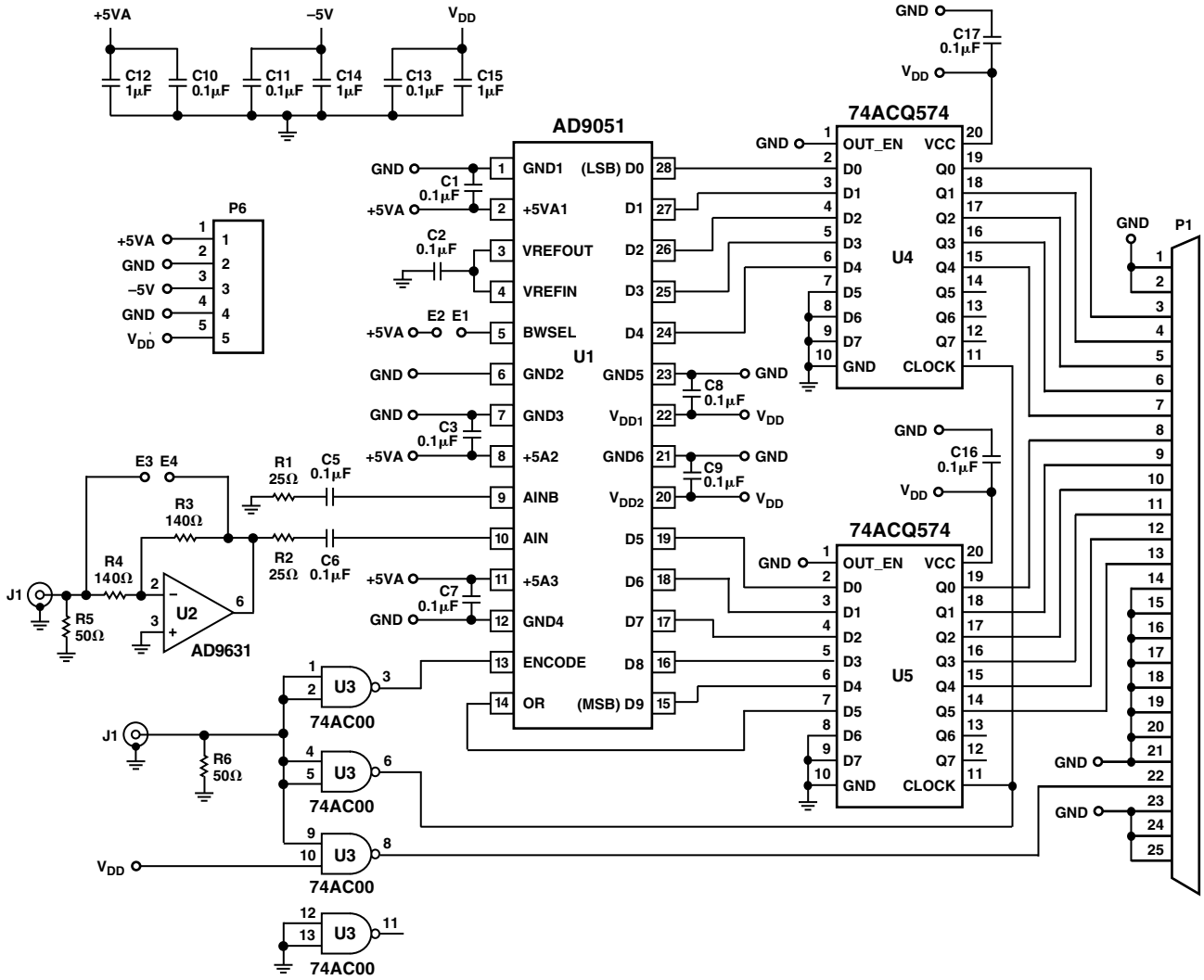
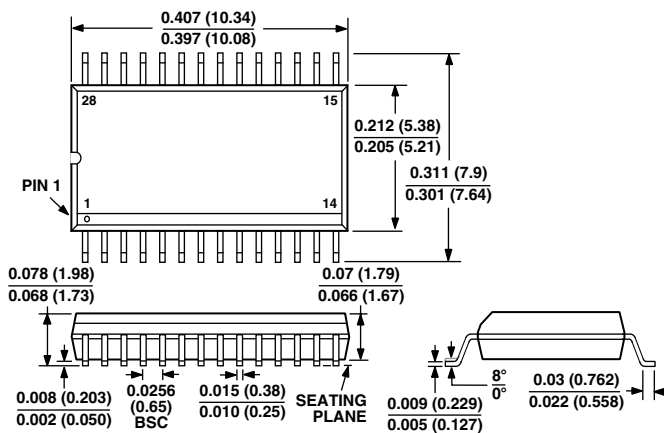

Figure 11. Evaluation Board Schematic

OUTLINE DIMENSIONS

Dimensions shown in inches and (mm).

28-Lead SSOP
(RS-28)



AD9051–Revision History

Location	Page
Data Sheet changed from REV. A to REV. B.	
Edit to ABSOLUTE MAXIMUM RATINGS	4

