

## Quad Monolithic SPST CMOS Analog Switches

### FEATURES

- $\pm 15\text{-V}$  Analog Input Range
- Low On-Resistance:  $60\ \Omega$
- Fast Switching: 130 ns
- Low Power Dissipation: 30 nW
- CMOS Logic Compatible

### BENEFITS

- Full Rail-to-Rail Analog Signal Range
- Low Signal Error
- Wide Dynamic Range
- Single or Dual Supply Capability
- Static Protected Logic Inputs
- Space Savings (TSSOP)

### APPLICATIONS

- Portable and Battery Powered Instrumentation
- Communication Systems
- Computer Peripherals
- High-Speed Multiplexing

### DESCRIPTION

Featuring low on-resistance ( $60\ \Omega$ ) and fast switching (130 ns), the DG308A is supplied in the “normally open” configuration while DG309 is supplied “normally closed.” Input thresholds are high voltage CMOS compatible.

voltage rating of 44 V, each switch conducts equally well in both directions when on, and blocks up to the supply voltage when off. An epitaxial layer prevents latch up.

Designed with the Vishay Siliconix PLUS-40 CMOS process to combine low power dissipation with a high breakdown

The DG308B/309B upgrades are recommended for new designs.

### FUNCTIONAL BLOCK DIAGRAM AND PIN CONFIGURATION

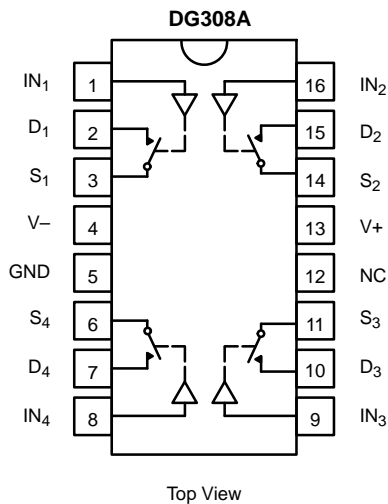

Four SPST Switches per Package

<b>TRUTH TABLE</b>		
Logic	DG308A	DG309
0	OFF	ON
1	ON	OFF

Logic "0"  $\leq 3.5\text{ V}$   
 Logic "1"  $\geq 11\text{ V}$

ORDERING INFORMATION		
Temp Range	Package	Part Number
0 to 70°C	16-Pin Plastic DIP	DG308ACJ
		DG309CJ
-40 to 85°C	16-Pin Narrow SOIC	DG308ADY
		DG309DY
	16-Pin TSSOP	DG308ADQ
		DG309DQ
-55 to 125°C	16-Pin CerDIP	DG308AAK/883
		DG309AK/883

**ABSOLUTE MAXIMUM RATINGS**

Voltages Referenced to V-

V+	44 V
GND	25 V
Digital Inputs <sup>a</sup> , V <sub>S</sub> , V <sub>D</sub>	(V-) -2 V to (V+) +2V or 20 mA, whichever occurs first
Current, Any Terminal Except S or D	30 mA
Continuous Current, S or D	20 mA
(Pulsed at 1 ms, 10% duty cycle max)	70 mA
Storage Temperature (AK Suffix)	-65 to 150°C
(CJ, DY, and DQ Suffix)	-65 to 125°C

Power Dissipation<sup>b</sup>

16-Pin Plastic DIP <sup>c</sup>	470 mW
16-Pin Narrow SOIC and TSSOP <sup>6</sup>	600 mW
16-Pin CerDip <sup>d</sup>	900 mW

Notes:

- a. Signals on S<sub>X</sub>, D<sub>X</sub>, or IN<sub>X</sub> exceeding V+ or V- will be clamped by internal diodes. Limit forward diode current to maximum current ratings.
- b. All leads welded or soldered to PC Board.
- c. Derate 12 mW/°C above 75°C
- d. Derate 6.5 mW/°C above 25°C
- e. Derate 7.6 mW/°C above 75°C

**SCHEMATIC DIAGRAM (TYPICAL CHANNEL)**

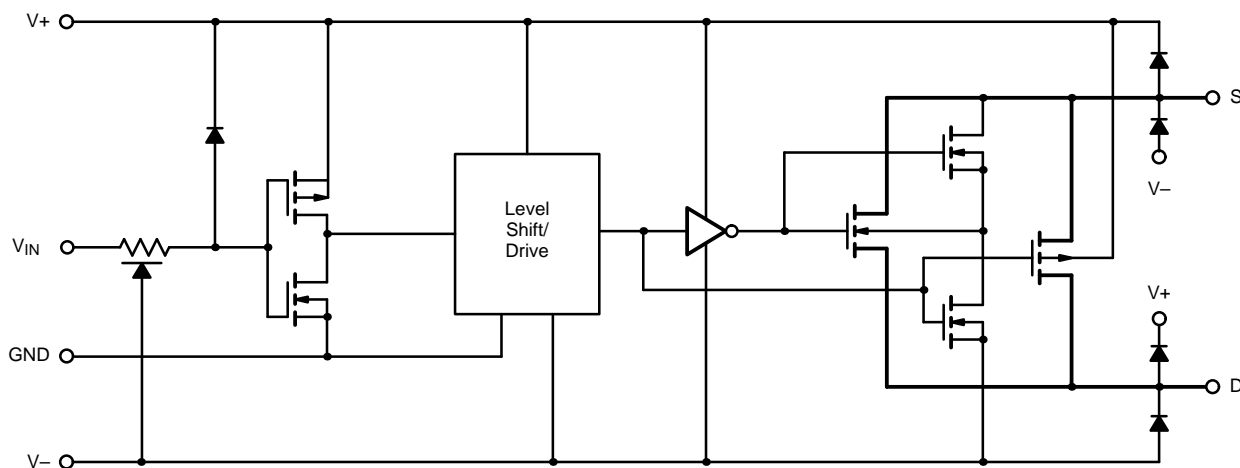

FIGURE 1.



SPECIFICATIONS <sup>a</sup>									
Parameter	Symbol	Test Conditions Unless Otherwise Specified $V_+ = 15\text{ V}$ , $V_- = -15\text{ V}$ $V_{IN} = 3.5\text{ V}$ or $11\text{ V}$ <sup>f</sup>	Temp <sup>b</sup>	Typ <sup>c</sup>	A Suffix -55 to 125°C		C, D Suffix		Unit
					Min <sup>d</sup>	Max <sup>d</sup>	Min <sup>d</sup>	Max <sup>d</sup>	
<b>Analog Switch</b>									
Analog Signal Range <sup>e</sup>	$V_{ANALOG}$		Full		-15	15	-15	15	V
Drain-Source On-Resistance	$r_{DS(on)}$	$V_D = \pm 10\text{ V}$ , $I_S = 1\text{ mA}$	Room Full	60		100 150		100 125	$\Omega$
Source Off Leakage Current	$I_{S(off)}$	$V_S = \pm 14\text{ V}$ , $V_D = \mp 14\text{ V}$	Room Full	$\pm 0.1$	-1 -100	1 100	-5 -100	5 100	nA
Drain Off Leakage Current	$I_{D(off)}$	$V_D = \pm 14\text{ V}$ , $V_S = \mp 14\text{ V}$	Room Full	$\pm 0.1$	-1 -100	1 100	-5 -100	5 100	
Drain On Leakage Current	$I_{D(on)}$	$V_D = V_S = \pm 14\text{ V}$	Room Full	$\pm 0.1$	-1 -100	1 100	-5 -200	5 200	
<b>Digital Control</b>									
Input Current with Input Voltage High	$I_{INH}$	$V_{IN} = 15\text{ V}$	Full	0.001		1		1	$\mu\text{A}$
Input Current with Input Voltage Low	$I_{INL}$	$V_{IN} = 0\text{ V}$	Full	-0.001	-1		-1		
Input Capacitance	$C_{IN}$		Room	8					pF
<b>Dynamic Characteristics</b>									
Turn-On Time	$t_{ON}$	See Figure 2	Room	130		200		200	ns
Turn-Off Time	$t_{OFF}$		Room	90		150		150	
Charge Injection	Q	$C_L = 0.01\ \mu\text{F}$ , $R_{gen} = 0\ \Omega$ , $V_{gen} = 0\text{ V}$	Room	-10					pC
Source-Off Capacitance	$C_{S(off)}$	$f = 140\text{ kHz}$ , $V_S$ , $V_D = 0\text{ V}$	Room	11					pF
Drain-Off Capacitance	$C_{D(off)}$		Room	8					
Channel-On Capacitance	$C_{D(on)}$		Room	27					
Off-Isolation <sup>f</sup>	OIRR	$R_L = 75$ , $V_S = 2\text{ V}_{p-p}$ , $f = 500\text{ kHz}$	Room	78					dB
<b>Power Supplies</b>									
Positive Supply Current	$I_+$	All Channels On or Off $V_{IN} = 0\text{ V}$ or $15\text{ V}$	Room Full	0.001		10 100		10 100	$\mu\text{A}$
Negative Supply Current	$I_-$		Room Full	-0.001	-10 -100		-100		

Notes:

- a. Refer to PROCESS OPTION FLOWCHART.
- b. Room = 25°C, Full = as determined by the operating temperature suffix.
- c. Typical values are for DESIGN AID ONLY, not guaranteed nor subject to production testing.
- d. The algebraic convention whereby the most negative value is a minimum and the most positive a maximum, is used in this data sheet.
- e. Guaranteed by design, not subject to production test.
- f.  $V_{IN}$  = input voltage to perform proper function.



**TYPICAL CHARACTERISTICS (25°C UNLESS NOTED)**

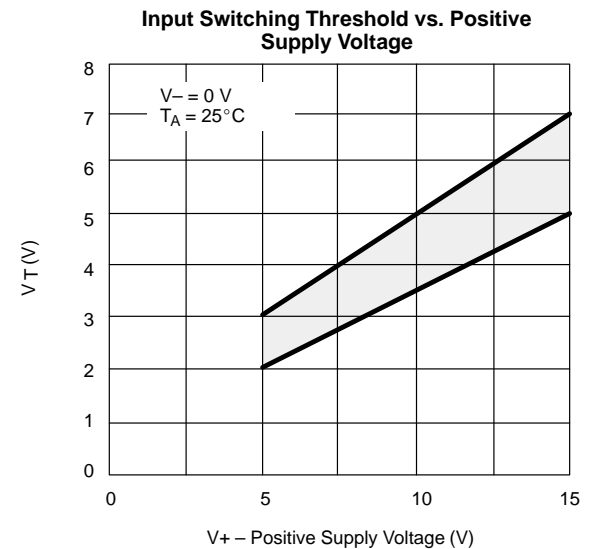
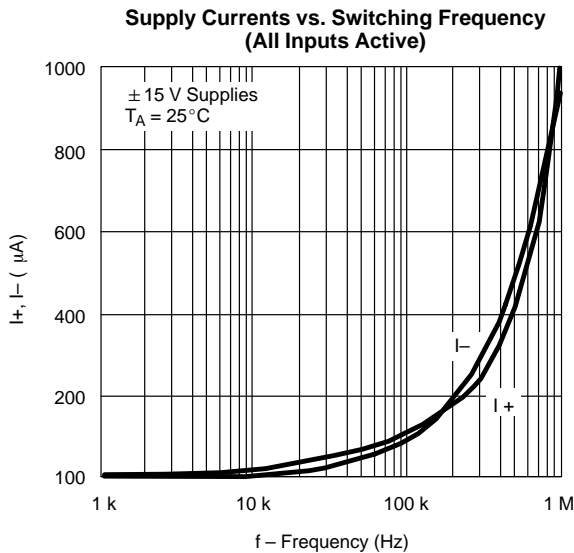
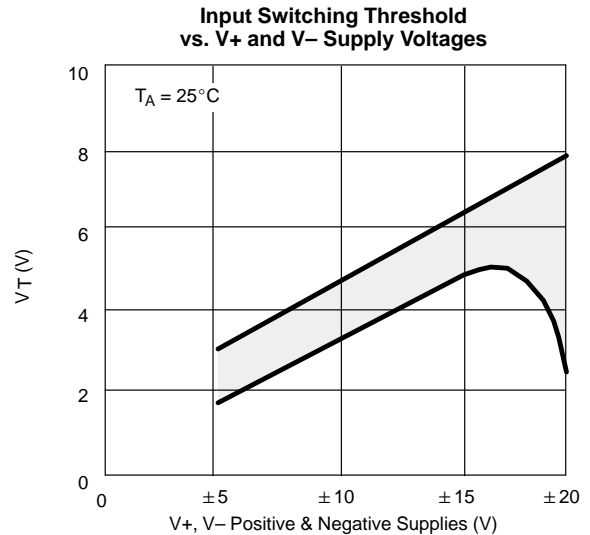
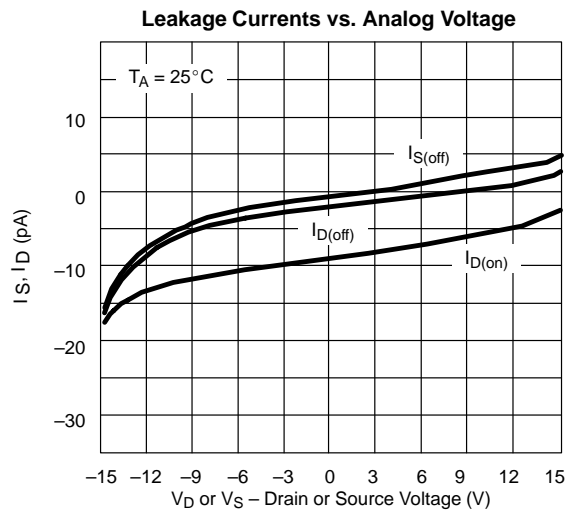
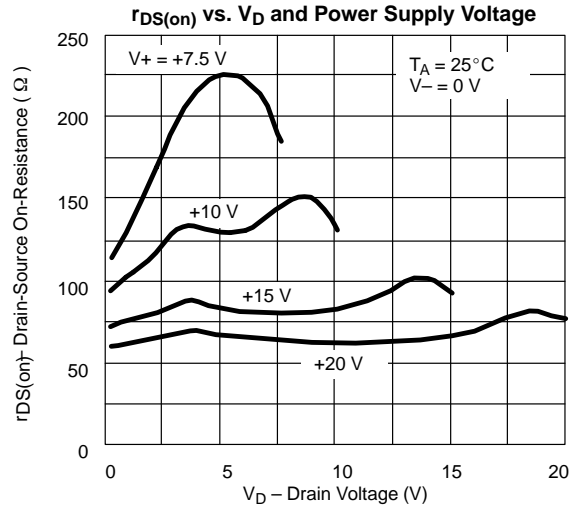
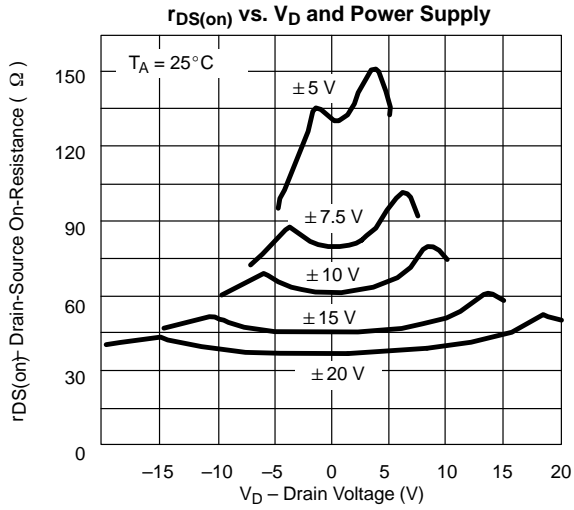

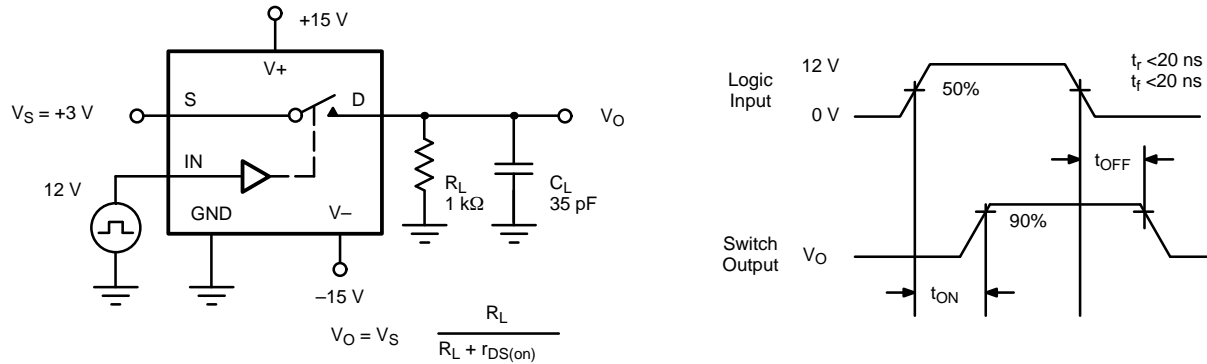
**TEST CIRCUITS**

**FIGURE 2. Switching Time**
**APPLICATIONS**
**Single Supply Operation**

The DG308A and DG309 will switch positive analog signals while using a single positive supply. This will allow use in many applications where only one supply is available. The trade-offs or performance given up while using single supplies are: 1) increased  $r_{DS(on)}$  and 2) slower switching speed. As stated in the absolute maximum ratings section of the data sheet, the analog voltage should not go above or below the supply voltages which in single supply operation are  $V+$  and 0 V.